

Counterweight-pendulum energy harvester with reduced resonance frequency for unmanned surface vehicles

James Graves, Yang Kuang, Meiling Zhu*

College of Engineering, Mathematics and Physical Sciences, University of Exeter, Exeter, EX4 4QF, UK



ARTICLE INFO

Article history:

Received 14 October 2020
 Received in revised form
 26 December 2020
 Accepted 22 January 2021
 Available online 28 January 2021

Keywords:

Energy harvesting
 Electromagnetic
 Pendulum
 Mechanical rotation rectifier
 Frequency tuning
 Wave energy

ABSTRACT

In this paper, a novel electromagnetic pendulum energy harvester with a counterweight is designed to harvest low frequency vibration from ocean waves for unmanned surface vehicles. This design is the first of its kind, allowing the natural resonant frequency of the pendulum to be reduced without increasing its length, thereby maintaining a high power output from the energy harvester at lower frequencies than previously possible with pendulums of the same size. Implementing a novel mechanical rotation rectifier (MRR) system for a high energy conversion efficiency, this counterweight pendulum energy harvester can provide multi-watt-level power at frequencies lower than 1 Hz, with a primary pendulum arm length of just 195mm. When actuated at 0.1 g rms, the pendulum energy harvester with a counterweight produced electrical power of 0.997 W at 0.75 Hz, compared to 0.168 W without the counterweight. The average normalised power output of the system at this frequency is 95.8 W/g², corresponding to a power density of 6.11 W/g²/kg. Testing of a range of configurations of the pendulum mass and counterweight shows a clear linear relationship between the ratio of lengths of the pendulum arms and the reduction of the natural frequency of the system. This demonstrates empirically that this device is capable of operating under conditions in which existing energy harvesters are unable to provide adequate power, and therefore provides a significant development in energy harvesting in an ultra-low frequency marine environment.

© 2021 The Authors. Published by Elsevier B.V. This is an open access article under the CC BY license (<http://creativecommons.org/licenses/by/4.0/>).

1. Introduction

Unmanned Surface Vehicles (USVs) are small, primarily autonomous vessels often used for exploration of the marine environment. These USVs are usually powered by some combination of batteries, fuel cells, and solar panels, allowing them to make short journeys for a number of days or weeks. However, there are significant limitations with the current power supply strategies; those relying on energy storage alone having finite journey times, and those with solar are limited to regions with sufficient sunlight to maintain energy stores. Energy harvesting can be used to capture energy from the ambient environment and store it in batteries, potentially providing sufficient power for an indefinite period of exploration and thus allowing USVs to be active for months at a time.

The most abundant energy source around the USVs is the motion of the waves. While a number of devices have been designed for wave energy harvesting, the majority of them rely on part of them being submerged in the water, making them unsuitable for USV

use [1,2]. Due to the energy harvester needing to be contained within the hull of the USV, it is therefore essential to review inertial energy harvesting techniques. The power consumption of an USV is estimated to be at least watt-level [3]. This power requirement is far beyond the state-of-the-art inertial energy harvesters based on piezoelectricity and linear electromagnetic transduction, which usually produces power outputs from a few microwatts to tens of milliwatts [4]. A potential method to achieve the required power level is by using a rotary motor driven by a pendulum with a low resonance frequency. In the previous study, the present authors developed a pendulum energy harvester capable of producing 0.72 W when actuated at 0.18 g and 1 Hz [5].

One of the main challenges of a pendulum energy harvester for wave motion energy harvesting is to achieve the low resonant frequency within a limited size, because the squared resonant frequency of a pendulum is inversely proportional to the arm length, i.e. the distance from the pivot to the mass. A pendulum with a natural frequency less than 1 Hz is usually too large to install within a small enclosed space. Within the energy harvesting community, there has been significant investigation into methods of tuning the resonant frequency of such devices irrespective of their arm length. Ding et al. [4] designed and tested a horizontal pendulum energy harvester for use in underwater mooring platforms, which had res-

* Corresponding author.
 E-mail address: m.zhu@exeter.ac.uk (M. Zhu).

onant frequencies in the range of 0.2–0.3 Hz when the pendulum had a pitch angle of 3–5 degrees. Adopting a different approach, Mitcheson et al. [6] used a power management circuit to adjust the electrical damping and natural frequency of an electromagnetic pendulum energy harvester, allowing a $\pm 10\%$ change in the resonant frequency. This design was further tested experimentally by Toh et al. [7] within a USV, demonstrating an ability to decrease the natural frequency by as much as 20%, but with the device only producing an average of 0.3 mW in real-world testing. Using a different electronic control strategy, Boren et al. [8] implemented a system whereby the generator is sometimes driven as a motor to assist in maintaining optimum pendulum motion for energy harvesting. Simulation results suggest an increase in performance with this kind of active control, though these have thus far only considered extremely large scale devices in the range of hundreds of kilowatts, and are yet to be validated experimentally. A similar approach by Wu et al. [9] uses a variable capacitive load to alter resonant frequency. Addressing the problem with a mechanical approach, Yurchenko et al. [10] proposed the concept of a pendulum with N equally spaced masses, as a method of isolating the natural frequency of the pendulum from its length. This shows theoretically that the presence of additional masses can reduce the natural frequency of a pendulum, with a prototype pendulum later tested experimentally by Alevras et al. [11].

Although the N-pendulum has shown capabilities in reducing the resonance frequency, its effectiveness for energy harvesting has not been studied since no energy harvester based on this mechanism has been built. This work therefore develops the first energy harvester based on the N-pendulum mechanism for USVs. The pendulum energy harvester consists of a primary pendulum mass as would be present in a traditional pendulum, with the addition of a smaller counterweight mass placed at 180° to it to reduce the resonant frequency. This allows the pendulum energy harvester to work at a lower frequency range without increasing its dimensions. A unique mechanical rotation rectifier is used to convert the oscillation of the pendulum to the unidirectional rotation of a DC generator to increase the efficiency of energy transduction. The design, fabrication, and testing of the counterweight pendulum energy harvester are reported in this work.

2. Theory of the counterweight pendulum

Fig. 1 shows a schematic of a counterweight pendulum, which consists of two rigid pendulum arms fixed at 180° to one another. The first holds the pendulum mass, m_M , placed at a length, L_M , from the centre of rotation, O . To the second is affixed the counterweight, m_C , at a distance, L_C , from point O . Assuming that the masses of the arms are small, the dynamics of the pendulum subjected to a horizontal excitation of $A\cos(\omega_f t)$ can be expressed as:

$$\begin{aligned} & (m_M L_M^2 + m_C L_C^2) \ddot{\theta} + c_d \dot{\theta} + (m_M L_M - m_C L_C) g \sin \theta \\ & = (m_M L_M - m_C L_C) \cos \theta \cdot A \cos(\omega_f t) \end{aligned} \quad (1)$$

where θ is the angular displacement; c_d is the damping coefficient; A and ω_f are the amplitude and frequency of the excitation acceleration. It is worthwhile pointing out that the pendulum may experience full rotation when actuated by rough waves. Therefore, the space allocated for a pendulum without a counterweight would be approximately the same as the pendulum with one.

When θ is small, the undamped resonance frequency of the pendulum is:

$$\omega_n = \sqrt{\frac{(m_M L_M - m_C L_C) g}{m_M L_M^2 + m_C L_C^2}} \quad (2)$$

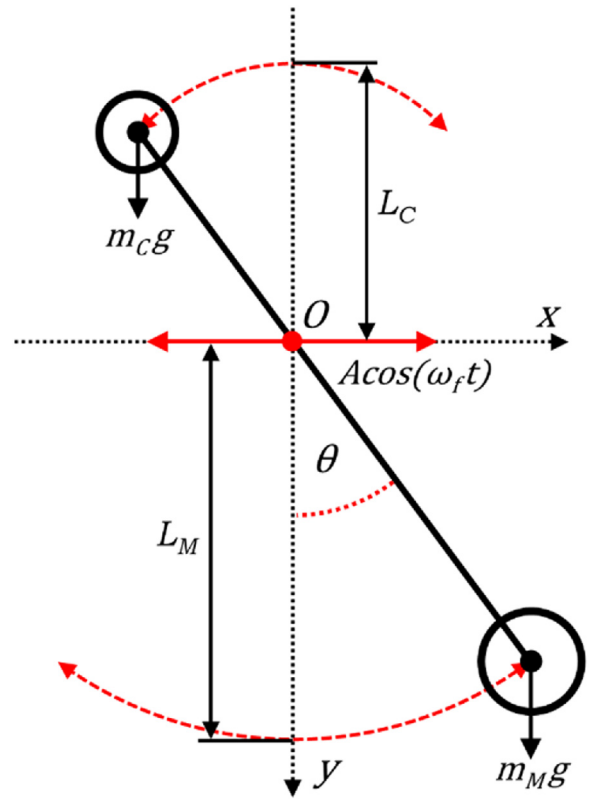

Fig. 1. Schematic of the counterweight pendulum.

Eq. (2) suggests that the resonance frequency decreases as either the mass of the counterweight m_C , or the length of the counterweight arm, L_C , is increased. This is because the counterweight reduces the restoring torque stiffness of the pendulum, which is $(m_M L_M - m_C L_C)g$, and increases the moment of inertia of the pendulum, which is $m_M L_M^2 + m_C L_C^2$.

3. Description of energy harvester design

Fig. 2 (a) shows the design of the pendulum energy harvester with counterweight to reduce its resonance frequency. It is composed of a pendulum frame, mass, counterweight, mechanical rotation rectifier (MRR) and a geared motor. The fixed central axis is mounted at its ends to the hull of the USV, shown in Fig. 2 (b), such that it cannot move. When excited by the pitching motion of the USV due to the ocean waves, the pendulum frame oscillates about the fixed central axis. The oscillation of the pendulum is transmitted to the input gears of the MRR, which rectifies the bidirectional oscillation to a unidirectional rotation. The gearhead increases the speed of the rotational output and transmits it to the DC motor to produce electricity.

In addition to the counterweight used to reduce the resonance frequency, the pendulum energy harvester in this study features a novel mechanical rotation rectifier design, which uses the minimum number of components to realise the motion rectification so as to maximise the efficiency while minimising backlash and complexity. The design and functionality of the MRR system mechanism is illustrated in Fig. 3. As shown in Fig. 4, Input Gear 1 and Input Gear 2 are each mounted to the outer race of one-way clutches, with supporting bearings to put the gears in double shear and hence reduce shear forces on the clutches to improve lifespan and efficiency. These one-way clutches are oriented in opposing directions, and both are mounted onto a collar which is fixed to the central shaft. As seen in Fig. 3 (a), the Idle Gear and Output

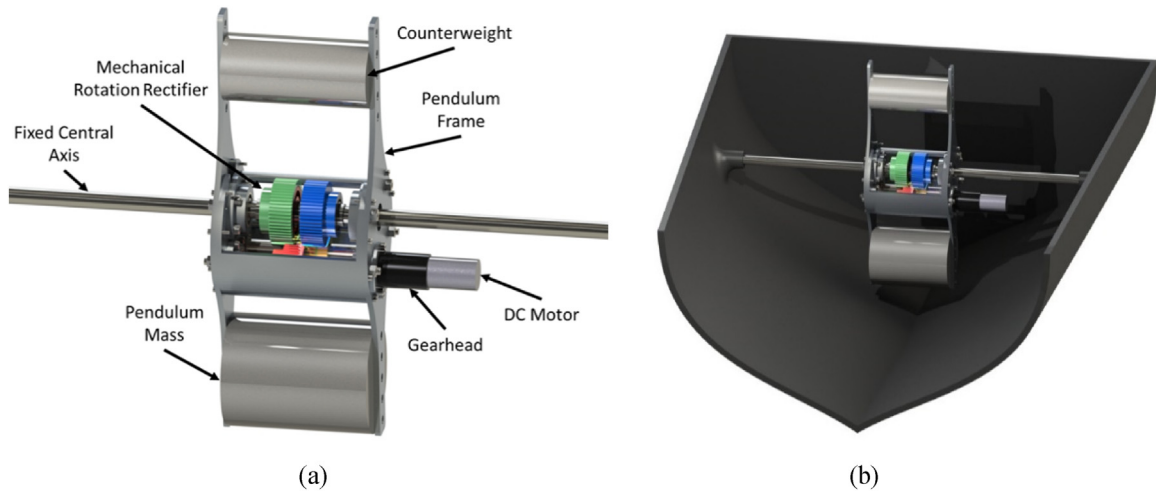

Fig. 2. Design of pendulum energy harvester with counterweight: (a) out of vessel, and (b) on board a section of a USV.

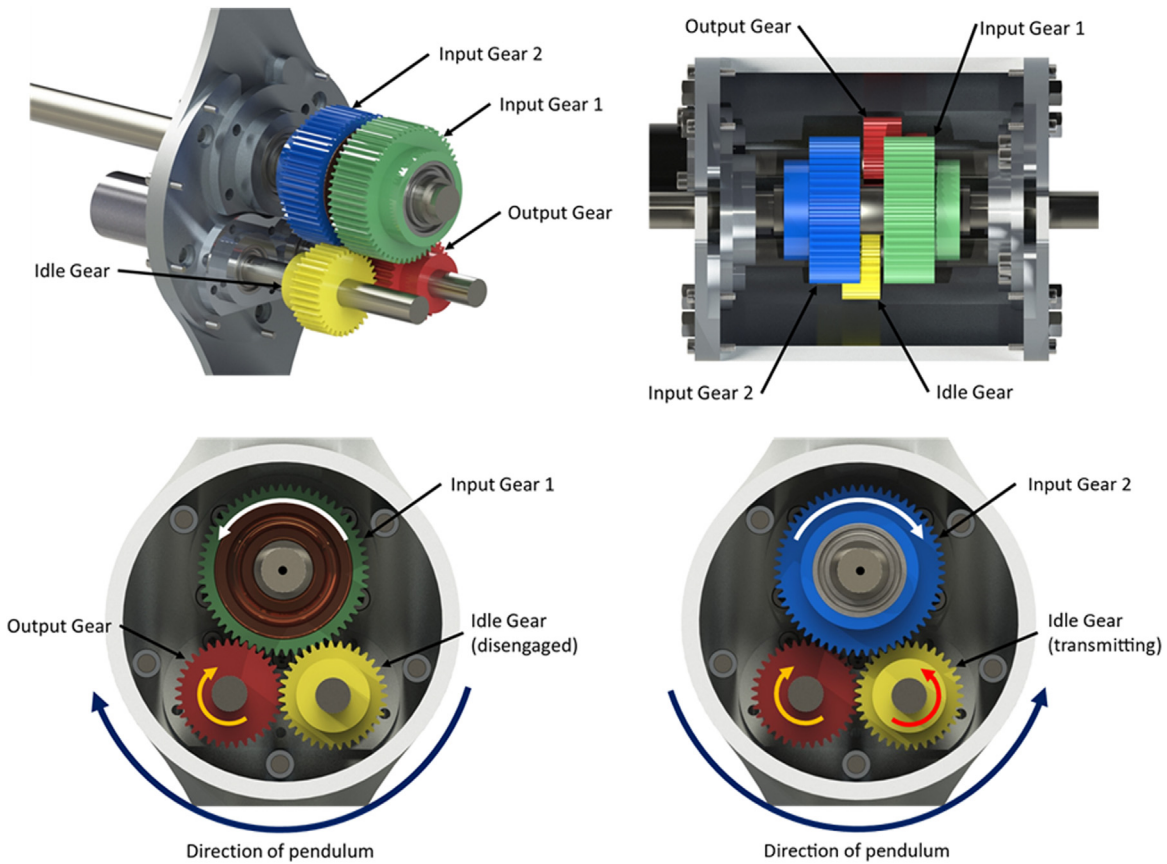

Fig. 3. Operation of the Mechanical Rotation Rectifier system during motion: (a) Gearing assembly, (b) Top-down view of gearing assembly, (c) End view during clockwise rotation of the pendulum, and (d) End view during anticlockwise rotation of the pendulum.

Gear are each mounted on separate smaller shafts, arranged such that they mesh with each other, with the Idle Gear also meshing with Input Gear 1 and the Output Gear meshing with Input Gear 2. The ability to transmit power in this way comes from offsetting the gears, as seen in Fig. 3 (b). It is this use of offset gearing which allows a minimal number of components to be used and hence maximises efficiency while minimising backlash and complexity. The power transmission through the gearing can be seen in Fig. 3 (c & d), as the pendulum frame rotates in the clockwise and anticlockwise directions. It should be noted that the inner races

of Input Gears 1 and 2 are fixed on the central axis and therefore each gear remains stationary during transmission, hence their effective directions of rotation within the MRR oppose that of the pendulum frame, as shown in Fig. 3. In the clockwise direction as shown in Fig. 3 (c), Input Gear 1 is effectively driven by the motion of the pendulum, which transmits torque directly to the Output Gear. In the anticlockwise direction, as shown in Fig. 3 (d), Input Gear 2 acts as a driving gear, which in turn transmits torque via the Idle Gear to drive the Output Gear. It can be seen, therefore, that the output will always be driven in the same direction,

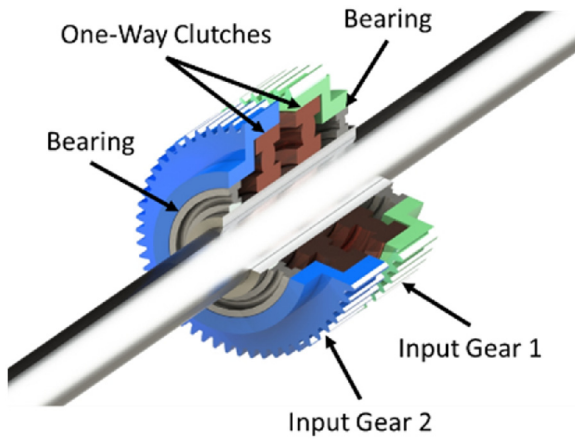

Fig. 4. Cutaway view of input gears, showing positions of clutches and bearings.

regardless of the direction of the input motion of the pendulum frame.

The energy harvester utilises a Faulhaber 2237S048CXR (Electro Mechanical Systems Ltd., Dorset, UK) DC motor as a generator, chosen primarily for its extremely low rotor inertia, minimising the torque required to drive it and hence maximising the power produced at any given speed. The gearhead used is a Portescap R32.0 99.8 (Portescap S.A., Neuchâtel, Switzerland) gearhead, which was selected primarily for its high torque capabilities as well as efficiency, with a ratio designed to enable the motor to maintain its optimum speed for power generation. Gearhead selection is first limited by torque capabilities, which must exceed the maximum dynamic torque out of the MRR, and a motor must be capable of handling the maximum expected power generated by the system. Based on these specifications, a gearhead and motor combination can be chosen based on the aforementioned selection criteria used here.

4. Experimental methods

The experimental setup for testing the pendulum energy harvester is shown in Fig. 5. The energy harvester was attached to the table of an APS 113 long stroke shaker (Techni Measure Ltd., Doncaster, UK) by fixing the ends of the central shaft to a steel frame. A Tektronix AFG3022C Function Generator (Tektronix UK Ltd., Berkshire, UK) was configured to produce a harmonic signal, which was amplified by an APS 125 Power Amplifier and then used to drive the shaker. The acceleration produced by the shaker, which is limited by its maximum displacement range of 150 mm, was monitored by Kistler 8762A5 accelerometer (Kistler Instruments Ltd., Hampshire, UK). The terminals of the DC motor were connected across an external load resistance box and the voltage across the load resistance was measured to calculate the average power generation.

The device parameters for the energy harvester are shown in Table 1. A pendulum mass of 7.9 kg and a counterweight of 4.4 kg were used. The arm length for the pendulum mass L_M was adjusted by securing the mass to two positions, labelled as M1 to M2 in Fig. 6. The arm length for the counterweight L_C was changed by securing the counterweight to three positions labelled as C1 to C3. When the counterweight was not used, the arm length for the counterweight L_C is effectively zero. The combination of L_M and L_C leads to in total six configurations of the pendulum energy harvester with the counterweight and two configurations without the counterweight, all of which were tested experimentally.

Table 1
Energy harvesting device parameters.

Energy Harvester Parameters	Value	Units
Motor nominal voltage	48	V
Motor no load speed	7000	rpm
Motor rotor inertia	3.1	g. cm ²
Motor speed constant	150	rpm/V
Motor torque constant	63.5	nNm/A
Motor terminal resistance	62.8	Ω
Gearhead gear ratio	99.8	–
Gear ratio of MRR	0.625	–
Mass of primary mass	7.9	kg
Mass of counterweight	4.4	kg
Total inertial mass with counterweight	15.6	kg
Dimensions of harvester	393(L)x230(W)x120(D)	mm

5. Experimental results and discussion

The representative voltage and energy output of the pendulum energy harvester with and without counterweight are presented, at their respective resonant frequencies of 0.65 and 1.1 Hz, in Fig. 7. For each case, the input excitation was fixed at the maximum displacement of the shaker, and so input acceleration varies with frequency. In both configurations, the voltages are of single polarity because the motor always rotates in a single direction due to the mechanical rotation rectifier. Without the counterweight, the pendulum energy harvester actuated at 0.2 g rms and 1.1 Hz produced 9160 mJ of energy in two seconds, corresponding to an average power of 4.58 W. The normalised energy output is therefore 114.5 W/g². When the counterweight was introduced with $L_C = 175$ mm, the pendulum energy harvester actuated at 0.13 g rms produced an energy of 1080 mJ after 2 s, corresponding to an average power of 0.54 W and normalised power of 32.0 W/g².

To determine the optimal load resistances for power generation, the power outputs of the pendulum energy harvester connected to different load resistances were measured. For each configuration, the excitation frequency was kept constant at the resonance frequency determined in initial tests. As expected, when L_M is fixed, the optimal load resistance for each configuration increases with L_C , as shown in Fig. 8. This is due to a decreasing net restoring torque as the counterweight arm length is increased, meaning that the lower impedance caused by a higher external load allows for higher efficiency motion of the pendulum.

Fig. 9 shows the normalised power output of the pendulum energy harvester against the excitation frequency. For each configuration, the optimal load resistance determined from Fig. 8 was used.

Without the counterweight, the pendulum energy harvester with $L_M = 195$ mm and $L_M = 155$ mm showed a resonance frequency of 1.1 and 1.2 Hz, respectively. As expected, based on Eq. (2), the resonance frequency of the pendulum energy harvester decreases as L_C increases. To evaluate the effectiveness of the counterweight in reducing the resonance frequency, frequency reduction ratio is considered, which is defined as:

$$\eta_f = \frac{f_0 - f_c}{f_0} \quad (3)$$

where f_c and f_0 are the resonance frequency of the pendulum energy harvester with and without the counterweight, respectively. With $L_M = 195$ mm and $L_M = 155$ mm, the frequency reduction ratio increases with L_C , as shown in Fig. 10 (a). With the same counterweight arm length, a larger frequency reduction ratio is achieved with a shorter L_M . When $L_C = 175$ mm, the resonance frequency of the pendulum is reduced by 0.53 with $L_M = 155$ mm, opposed to the reduction by 0.41 with $L_M = 195$ mm. This is because the resonance frequency is dependent on the ratio of L_C to L_M , as can be verified by plot of η_f against L_C/L_M in Fig. 10 (b). The same frequency reduc-

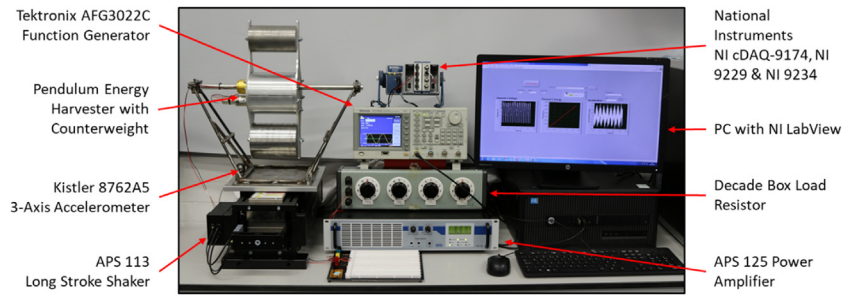

Fig. 5. Experimental setup for the low frequency pendulum energy harvester.

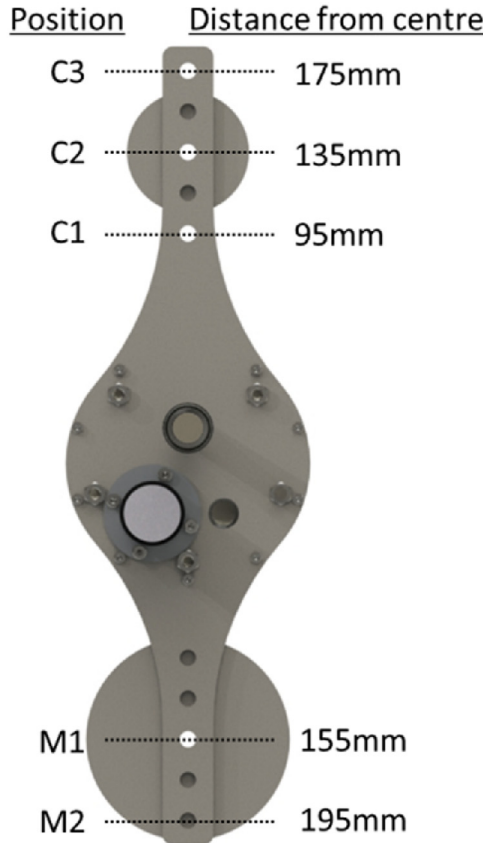

Fig. 6. Positions of pendulum mass and counterweight with respect to centre of rotation.

tion ratio is obtained when L_C/L_M is the same, regardless of the values of L_M . From Eq. (2), calculated values of η_f are also shown in Fig. 10 to validate the mathematical description of the energy harvester. Based on this validation, it is then possible to predict the frequency reduction ratio of the device under given size constraints, with varying values of m_C/m_M , as shown in Fig. 11.

While the counterweight reduces the resonance frequency, it negatively impacts the power output at the resonance frequencies, as can be seen in Fig. 9. This is because the inertial forces experienced by the pendulum mass and the counterweight always generate opposite moments. As a result, the total input torque to the pendulum, which can be obtained from Eq. (2), is:

$$\tau = (m_M L_M - m_C L_C) A \cos(\omega_f t) \tag{4}$$

Eq. (4) clearly shows that the counterweight reduces the torque input to the pendulum energy harvester due to the reduced torque stiffness of the harvester. As a consequence, the power output is

reduced at the resonant frequency. Nevertheless, it should be highlighted that the pendulum energy harvester with counterweight is capable of operating at a lower frequency vibration from ocean waves. Results from Fig. 9 suggest that with the same arm length or volume, the pendulum energy harvester with counterweight is able to produce a significantly higher power output at lower frequencies. For example, the pendulum energy harvester without the counterweight produces 16 W/g^2 at 0.75 Hz when the pendulum arm length is 195 mm. Without increasing the volume occupied by the pendulum, the addition of a counterweight with $L_C = 135 \text{ mm}$ increases the power output at 0.75 Hz by 5.95 times to 95.34 W/g^2 . Table 2 compares the performances of low-frequency vibration energy harvesters in the literature. This demonstrates the advantage of this device over existing designs as it capable of operating at the low frequencies present on board a USV, where existing designs are unusable. At the same time, the counterweight pendulum energy harvester is able to maintain a high power density at

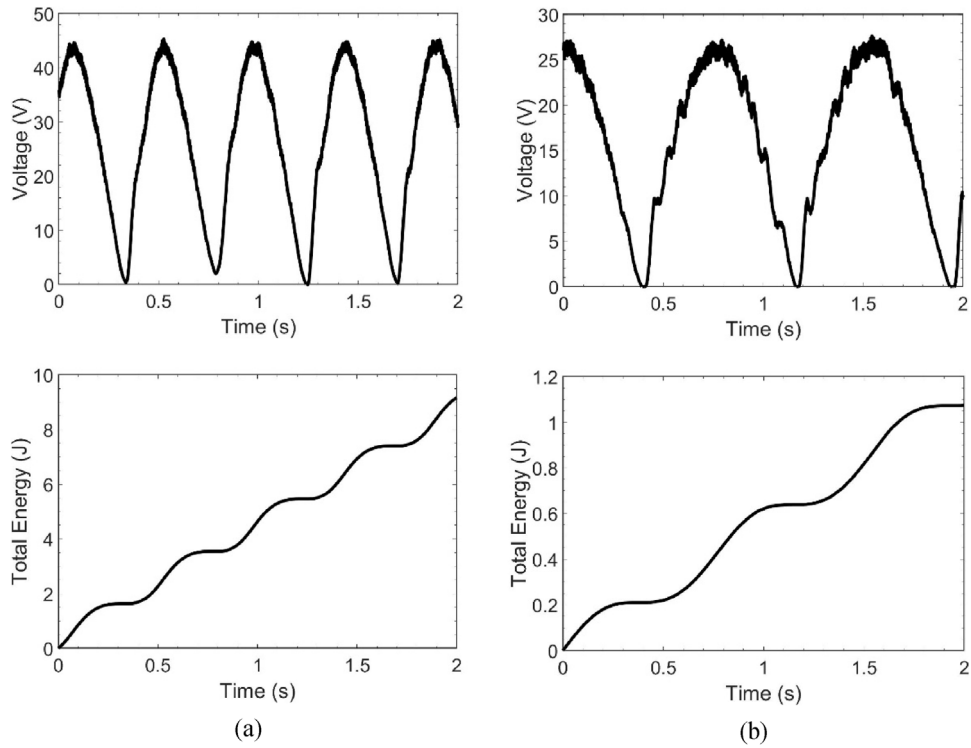

Fig. 7. Output of the pendulum energy harvester with $L_M = 195$ mm: (a) without counterweight, actuated at 0.2 g, 1.1 Hz with 200 Ω load resistance; (b) with counterweight of $L_C = 175$ mm, actuated at 0.13 g, 0.65 Hz with 600 Ω resistance.

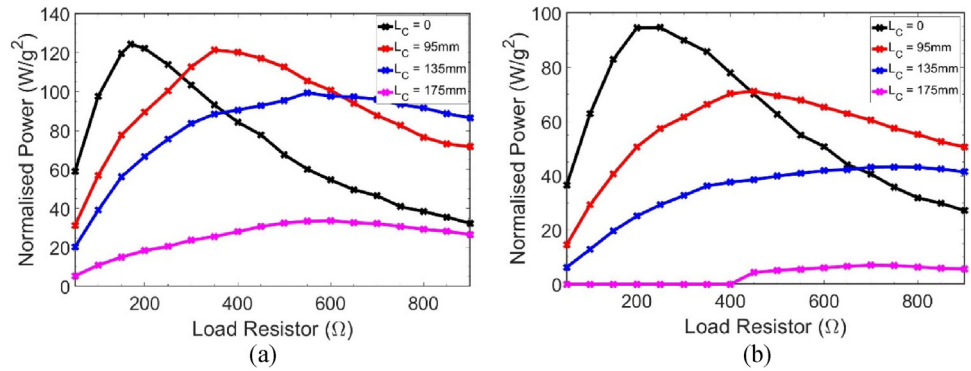

Fig. 8. Optimal load testing of energy harvester with mass at position (a) $L_M = 195$ mm, and (b) $L_M = 155$ mm, with varying counterweight positions, at resonant frequency of each configuration.

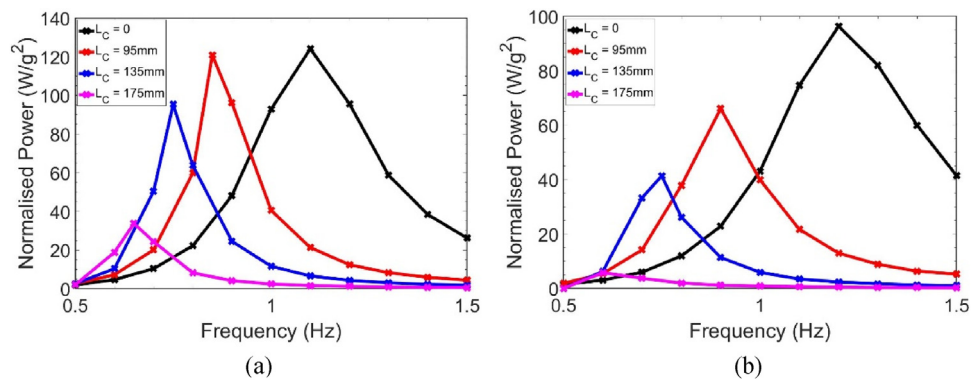

Fig. 9. Normalised power output of the pendulum energy harvester with different L_C when (a) $L_M = 195$ mm and (b) $L_M = 155$ mm. $L_C = 0$ means that no counterweight is attached.

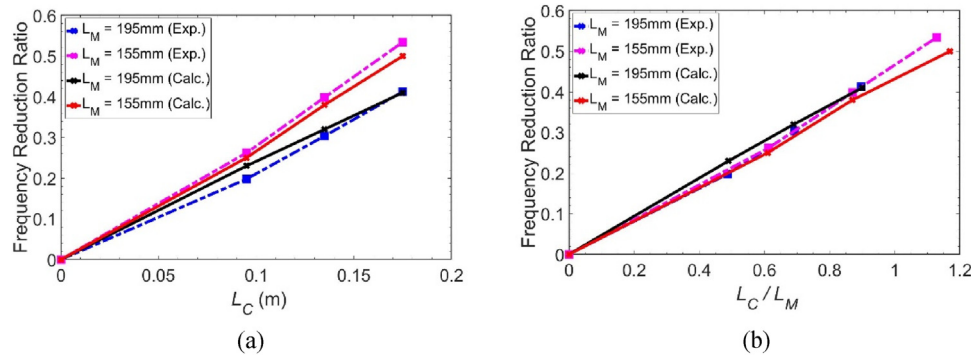

Fig. 10. Variation of the frequency reduction ratio against (a) L_C and (b) L_C/L_M .

Table 2
Comparison of low frequency vibration energy harvesters.

Energy Harvester	Type	$L_M; L_C$ (mm)	Frequency(Hz)	Acceleration (g)	Inertial Mass (kg)	Power (mW)	NPD(W/g ² /kg)
This work	EM	195; 135	0.75	0.102	15.6	997	6.11
		195; 0	1.1	0.110	11.1	1497	11.15
Graves et al. [5]	EM	-	1	0.186	1.6	720	12.32
Liang et al. [12]	EM	-	1	-	0.36	-	1.6
Saha et al. [13]	EM	-	2.5	1	0.027	1.86	0.069
Kuang et al. [14]	EM	-	5.8	0.2	0.014	1.31	2.37
Arakawa et al. [15]	ES	-	10	0.40	0.7×10^{-3}	6×10^{-3}	0.054

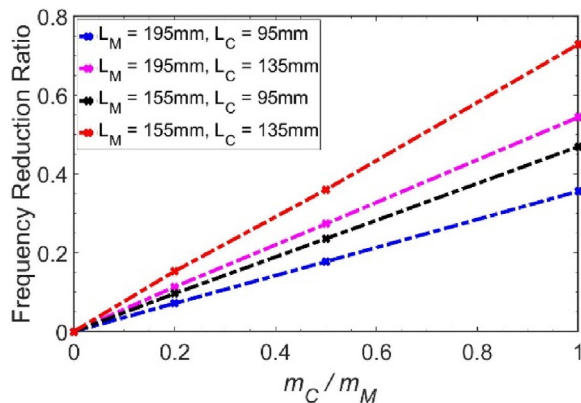

Fig. 11. Calculated variation of the frequency reduction ratio against m_C/m_M .

these frequencies, making it suitable for real-world use in ultra-low frequency environments.

6. Conclusion

In this paper, a novel design of a counterweight-pendulum to reduce the natural frequency of a pendulum energy harvester has been proposed, fabricated, and tested experimentally for harvesting low frequency vibration from ocean waves for unmanned surface vehicles. The inclusion of adjustable pendulum and counterweight arms has allowed a variety of configurations to be tested and therefore analysed based on empirical evidence. The optimal load resistance for each configuration was first determined at the resonance frequency. Following that, the maximum power output of each configuration was measured with the energy harvester connected to the optimal load. The experimental results have proven the ability of the counterweight to tune the system to different resonant frequencies; this reduction in resonant frequency has been shown to be linearly proportional to the ratio of the mass arm lengths. The counterweight has been shown to increase the output power at certain lower frequencies by as much as a factor of 5.95, showing conclusively that this energy harvester design is capable

of reducing the natural frequency of a pendulum without increasing its length, while also maintaining sufficient power output of the device at these lower frequencies. Demonstrating this high power output at low frequencies in the 0.5–1 Hz range, it is clear that this device could be extremely promising for future developments in creating low frequency vibration energy harvesters for USVs in real-world situation.

CRediT authorship contribution statement

James Graves: Conceptualization, Methodology, Validation, Formal analysis, Investigation, Writing - original draft, Writing - review & editing, Visualization. **Yang Kuang:** Methodology, Formal analysis, Resources, Writing - review & editing, Supervision. **Meiling Zhu:** Resources, Writing - review & editing, Supervision, Project administration, Funding acquisition.

Declaration of Competing Interest

The authors declare that they have no known competing financial interests or personal relationships that could have appeared to influence the work reported in this paper.

Acknowledgements

This research is funded by the EPSRC Standard Research Studentship (DTP), Grant No. EP/R512254/1.

References

- [1] B. Drew, A. Plummer, M. Sahinkaya, A review of wave energy converter technology, Proc. Inst. Mech. Eng. Part A J. Power Energy 223 (2009) 887–902.
- [2] E. Al Shami, R. Zhang, X. Wang, Point absorber wave energy harvesters: a review of recent developments, Energies 12 (1) (2018) 47.
- [3] N.C. Townsend, Self-powered autonomous underwater vehicles: results from a gyroscopic energy scavenging prototype, Iet Renew. Power Gener. 10 (8) (2016) 1078–1086.
- [4] W. Ding, et al., Experimental investigations on a low frequency horizontal pendulum ocean kinetic energy harvester for underwater mooring platforms, J. Mar. Sci. Technol. 21 (2) (2016) 359–367.
- [5] J. Graves, Y. Kuang, M. Zhu, Scalable pendulum energy harvester for unmanned surface vehicles, Sens. Actuators A Phys. (2020), 112356.

- [6] P.D. Mitcheson, et al., Tuning the resonant frequency and damping of an electromagnetic energy harvester using power electronics, *Ieee Trans. Circuits Syst. II Express Briefs* 58 (12) (2011) 792–796.
- [7] T.T. Toh, et al., Electronic Resonant Frequency Tuning of a Marine Energy Harvester, 2011.
- [8] B.C. Boren, B.A. Batten, R.K. Paasch, Active control of a vertical axis pendulum wave energy converter, 2014 American Control Conference (2014).
- [9] W.-J. Wu, et al., Tunable Resonant Frequency Power Harvesting Devices. In *Smart Structures and Materials 2006: Damping and Isolation*, International Society for Optics and Photonics, 2006.
- [10] D. Yurchenko, P. Alevras, Dynamics of the N-pendulum and its application to a wave energy converter concept, *Int. J. Dyn. Control.* 1 (4) (2013) 290–299.
- [11] P. Alevras, I. Brown, D. Yurchenko, Experimental investigation of a rotating parametric pendulum, *Nonlinear Dyn.* 81 (1–2) (2015) 201–213.
- [12] L. Changwei, W. You, Z. Lei, Broadband pendulum energy harvester, *Smart Mater. Struct.* 25 (9) (2016), 095042.
- [13] C.R. Saha, et al., Electromagnetic generator for harvesting energy from human motion, *Sens. Actuators A Phys.* 147 (1) (2008) 248–253.
- [14] Y. Kuang, R. Hide, M. Zhu, Broadband energy harvesting by nonlinear magnetic rolling pendulum with subharmonic resonance, *Appl. Energy* 255 (2019), 113822.
- [15] Y. Arakawa, Y. Suzuki, N. Kasagi, Micro seismic power generator using electret polymer film, *The Proceedings of the National Symposium on Power and Energy Systems* (2004), 2004.9.

Biographies



James Graves received his M.Eng in Electronic Engineering with Industrial Experience from University of Exeter in 2017. He is currently working towards his PhD in Energy Harvesting, with a focus on extending the operational time of unmanned surface vehicles through the implementation of low frequency vibration energy harvesting transducers.

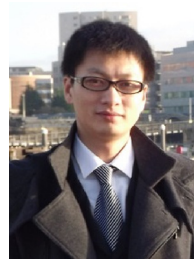

Yang Kuang received his B.Eng and M.Eng in Mechanical Engineering from Central South University, China, in 2007 and 2010, respectively, and his PhD in high power piezoelectric transducers from University of Dundee in 2014. He is currently working as a research fellow in the energy harvesting research group in University of Exeter. His main research interests are focused on self-power wireless sensing systems enabled by energy harvesting.



Meiling Zhu received the B.Eng., M.Eng., and Ph.D. degrees from Southeast University, Nanjing, China, in 1989, 1992, and 1995, respectively. She is currently a Professor and the Chair of Mechanical Engineering and the Head of the Energy Harvesting Research Group with the University of Exeter, U.K. Her current research is concentrated on piezoelectric energy harvesting powered wireless communication and sensor nodes.