

Phase-resolved heave plate dynamics for wave energy converters

Adam C Brown* and
Jim Thomson
University of Washington -
Applied Physics Lab
Seattle, WA, USA

*Corresponding author: brownapl@uw.edu

1. INTRODUCTION

All wave energy converters (WECs) must resist the motion of the incident wave. The reaction forces developed by the power take-off (PTO) of the WEC are either transferred outside the system or to the inertia of the WEC. If the reaction forces are transferred to the inertia of the WEC, the WEC must be massive, and thus expensive. System mass and cost can be reduced through the use of a heave plate. Heave plates are large plates or structures attached to or suspended well below the WEC in water at a depth where the motion of the waves passing over the water's surface has been substantially attenuated. At this depth, the heave plate can transfer the reaction loads developed by the WEC to the inertia of the water.

Despite their importance to and prevalence in WEC design [1, 2], heave plate dynamics have received little attention in the literature. Parametric studies are needed to understand the effect of variations in design on heave plate performance, and tests at varying scale will be needed to determine how the hydrodynamic performance of a heave plate scales with size.

The hydrodynamic behavior of heave plates is studied in two experiments. First, a custom measurement platform has been built and used to calculate coefficients of drag and added mass for 12-*in* diameter heave plates forced through sinusoidal oscillations of varying amplitude and frequency. Several heave plate variations were tested, and the results are briefly discussed. Second, the miniWEC, a small wave energy converter is being built and instrumented to study the performance of 60-*in* diameter heave plates. The results of the forced oscillations in the first experiment were used to inform the design of the heave plates that will be deployed with the miniWEC. These experiments will provide insight into how the hydrodynamic behavior of heave plates scales with heave plate size.

2. BACKGROUND

Heave plates have been used to reduce the motion of SPAR type offshore drilling platforms [3, 4]. However, the oscillations of SPAR platforms are vastly different than the oscillations of a WEC, thus the range of experimental conditions tested in the literature tends to fall outside the conditions of interest for wave energy conversion. The literature related to heave plates in the context of offshore oil also tends to focus on solid and perforated flat plates. WECs may benefit from more complicated heave plates with asymmetric shape and behavior, such that the hydrodynamic characteristics of the heave plate depend on the direction of motion through the water column [5]. This effect may be of particular importance to WECs which use a flexible connection to the heave plate as a means of reducing snap loads.

Several authors have used oscillatory motion to characterize heave plate hydrodynamic behavior in terms of the coefficients of added mass (C_m) and drag (C_d), or simply a damping ratio [4, 6, 7, 8]. The damping ratio is determined by examining the decay of a perturbation. Several methods have been used to determine C_d and C_m . All methods require that the motion of the heave plate and the hydrodynamic load on the heave plate are simultaneously recorded for many oscillations. For this work, the hydrodynamic loads on the heave plate are modeled using the Morison Equation, and a best fit of the Morison Equation to the recorded load data provides C_d and C_m for the heave plate.

The Morison equation was originally developed to describe the force on a vertical pile due to the oscillations of the surrounding water. It can also be used to model the hydrodynamic forces on a heave plate. In the case of the heave plate, the water is typically assumed stationary, and thus relative velocity is solely due to the motion of the heave plate as it moves vertically through the water column.

$$F = C_m \left(\rho V \frac{d^2 z}{dt^2} \right) + C_d \left(\rho A \frac{dz}{dt} \left| \frac{dz}{dt} \right| \right) \quad (1)$$

The resulting force F is comprised of two components: an inertial component that describes the force on the

heave plate due to the acceleration (d^2z/dt^2) it imparts on the surrounding water, and a drag component that models the force on the heave plate due to the generation of turbulent eddies in the wake of the heave plate. Assuming the surrounding water is still, the drag force is proportional to the square of the heave plate velocity (dz/dt).

In equation 1, V is the volume of water contained in a sphere having a diameter equal to that of the heave plate, ρ is the density of water, and A is the projected area of the heave plate normal to the flow.

For scaling purposes, oscillatory hydrodynamic coefficients are often related to the non-dimensional Keulegan-Carpenter number (KC), which describes the relative importance of drag forces compared to inertial forces. After simplification, KC is only dependent on the oscillation amplitude a and a characteristic length L here specified the diameter of the heave plate, D .

$$KC = 2\pi a/D \quad (2)$$

Li et al. found that C_d and C_m remain nearly constant at a given KC regardless of the oscillation frequency [7]. However, the dependence of C_d on Reynold's number (Re), which is proportional to velocity, suggests that oscillation frequency will effect C_d . The KC dependence of the heave plate hydrodynamic coefficients is one focus of this research.

Another focus of the research is to study the effect of asymmetric shapes on hydrodynamic behavior. In order to avoid slack loads in a heave plate tether, it may be beneficial to allow a heave plate to fall through the water column more easily than it is raised [9].

3. AN OSCILLATING TEST PLATFORM

3.1 Design and Operation

An oscillating test platform, called the Oscillator, has been developed to study the hydrodynamic behavior of small scale heave plates (12-*in* diameter) forced through sinusoidal motion. The Oscillator uses a servomotor driven belt-and-carriage linear actuator to force heave plates vertically up and down through the water column (Figure 1).

Heave plates are mounted to the bottom of a push-rod driven by the actuator carriage. A 300-*lb* S-beam load cell is used to measure the force driving the heave plate and push-rod. The output from the servomotor's high accuracy analog resolver (rotary position) is converted to provide the linear position of the carriage. Heave plate velocity and acceleration are later obtained through differentiation (center difference) of the recorded linear position.

The Oscillator was positioned at the edge of the Applied Physics Lab's dock, with the push-rod and heave plate extending approximately 36-*in* underwater. The mounted heave plate was then forced through sinusoidal oscillations of varying amplitude and frequency. As tests occurred in a lake, reflected waves were not an issue. However, local wind waves and wakes from boat traffic were present. Data was taken over many oscillations to limit the effect of wind waves and wakes.

A sinusoidal analog signal corresponding to an oscil-



Figure 1: The oscillator measures heave plate position, and the force needed to drive the heave plate. The data is used to calculate phase-resolved hydrodynamic coefficients for the heave plate.

lation of a given amplitude and frequency is generated using Labview and is used by the motor controller as the commanded position input for the linear actuator. Within the same Labview program, the actual motion and resulting load on the heave plate are recorded at a minimum of 50-*Hz*. Motion is ramped to full amplitude, and prior to analysis, the first ten oscillations are cropped from the data to minimize the impact of transient behavior. Due to the limitations of mechanical, servo driven systems, the oscillations are not, and can not be perfectly sinusoidal, however this fact does not limit Morison based solution techniques as long as the actual position of the heave plate is used to determine heave plate velocity.

Peak-to-peak oscillations between 2.5-*cm* and 70-*cm* were tested with periods ranging between 0.5-*s* and 4-*s*. Each combination of test parameters was repeated for four different heave plate variations: 1) a Flat Plate, 2) a Flat Plate with 4-*in* central hole, 3) a Conic with 45° sidewalls and a 4-*in* central hole, and 4) a Conic with 60° sidewalls and a 4-*in* central hole. Both of the conics were mounted with their wide sides up. The 60° conic can be seen mounted to the Oscillator in Figure 1.

3.2 Initial Results

A representative segment of data from the Oscillator

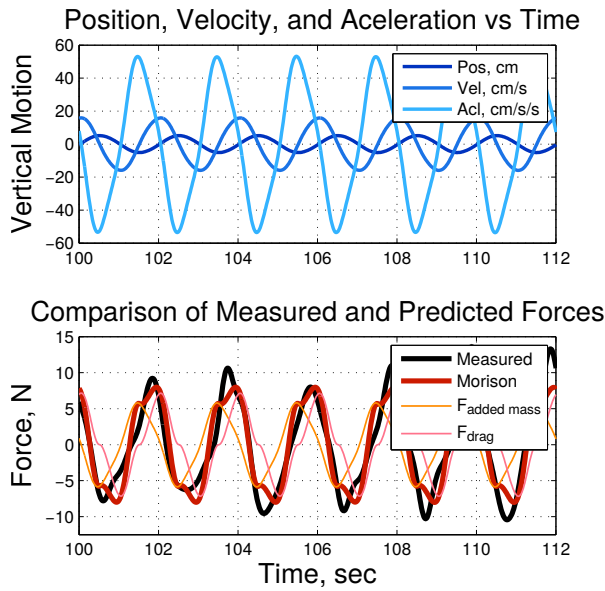

Figure 2: Snapshot of the motion data for the 45° conic showing heave plate motion and loading for a 10-cm oscillation with a 2-s period. The force predicted by the constant coefficient Morison equation for the recorded motion is also shown.

is shown in Figure 2. The input oscillation had a peak-to-peak height of 10-cm and a period of 2-s which results in a KC approximately equal to the KC number of a 60-in heave plate oscillating in wind waves on Lake Washington. The weight and dynamic buoyancy of the rod and heave plate have been subtracted from the recorded force which has been low-pass filtered with a cut-off frequency of 2-Hz.

For each data set, a least squares optimization of the Morison Equation is used to calculate a single value for C_d and C_m that best predicts the hydrodynamic forcing given the recorded motion. These values will be called the *constant coefficient* values. The hydrodynamic force on the heave plate as predicted by the Morison Equation using the optimized constant coefficients is shown in the lower panel of Figure 2. The Morison Equation with constant coefficients provides a reasonable approximation of the actual forces observed, but tends to miss the maxima and minima of the force. The measured force is biased towards tension which is likely due to the asymmetric shape of the heave plate. This bias cannot be replicated using a constant coefficient Morison approximation of the hydrodynamic forces which by definition estimate a force with zero mean for sinusoidal motion.

The constant coefficients calculated from each test are shown in Figure 3. Both coefficients show frequency dependence. Longer period oscillations show elevated C_d and reduced C_m across all KC . The Reynold's dependence leads larger amplitude oscillations to result in a reduced C_d , which collapses to a value of approximately 2.5 for all heave plate variations when KC is greater than 5.0. C_m increases with oscillation amplitude, and the three heave plates with a central hole all have C_m

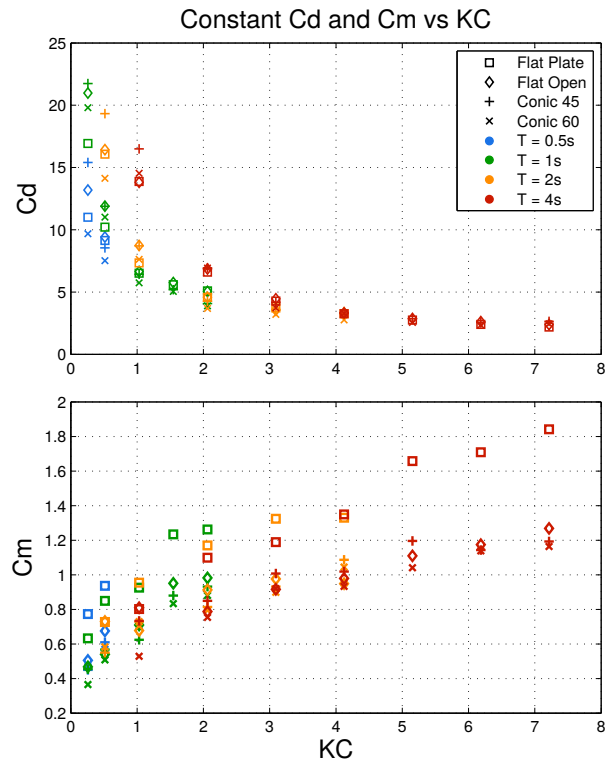

Figure 3: The constant hydrodynamic coefficients calculated for each test case are compared to the KC number of the oscillation.

less than that of the simple flat plate. C_d and C_m for the 60° degree conic are slightly reduced from the values of the 45° conic, however the change in geometry appears to have only a minor effect on hydrodynamic performance.

To investigate the single cycle variability of C_d and C_m , an ensemble average of the individual wave cycles was calculated which provides a robust quantification of the hydrodynamic forcing as it varies with the phase of the oscillation. The least squares regression technique previously used to calculate the constant hydrodynamic coefficients was modified to calculate phase dependent hydrodynamic coefficients for the ensemble average wave of each data set. The results of this analysis for the 10-cm, 2-s oscillation are shown in Figure 4. The constant coefficient values of C_d and C_m are also shown for reference.

The Morison equation using variable coefficients provides a better approximation of the measured hydrodynamic force, and allows the positive mean force (tension in rod) observed in the recorded data to be replicated. Upwards motion corresponds to an increased C_d . Directional variation in added mass is minimal and shows greater test-to-test variation. The circular and diamond shaped markers shown in Figure 4 are data points with nearly identical velocities and accelerations; however, the points do not share common coefficients. The “looping” trace of C_d and the “bow-tie” trace of C_m are present in all test runs for all heave plate variations. The behavior is likely due to the fact that the motion

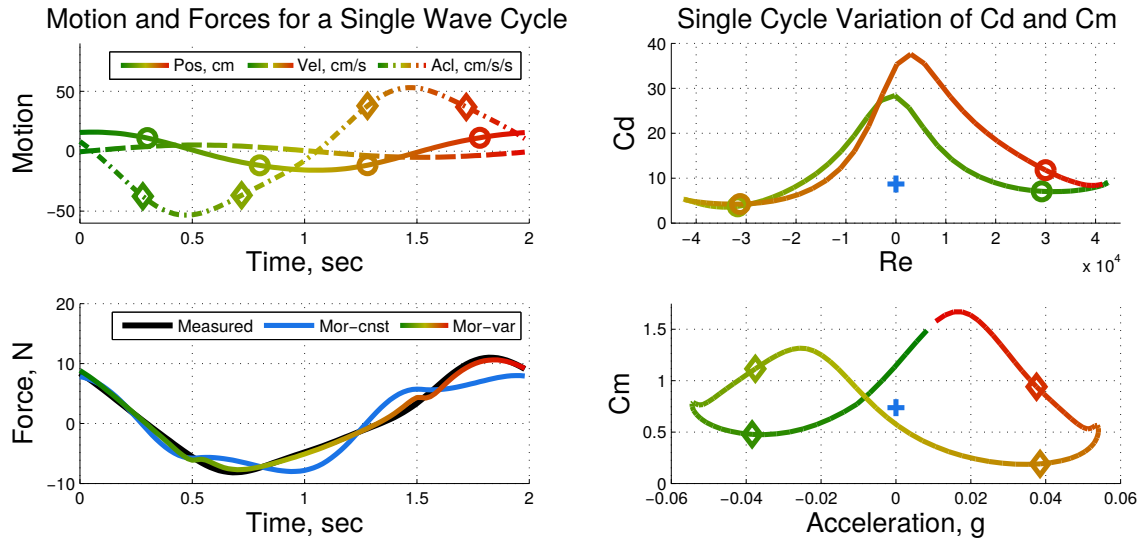

Figure 4: The average 10-cm 2-s oscillation is shown for the 45° conic. The circles and diamonds are points with nearly equal velocity or acceleration. Phase-space diagrams of C_d and C_m show variation with oscillation phase (start = green, stop = red). The constant coefficients are also marked for reference.

of the heave plate induces an oscillatory flow in the surrounding water, and thus the relative velocity of the heave plate and water differs from the velocity of the heave plate. This effect will be investigated in future work.

4. THE MINIWEC TEST PLATFORM

A small wave energy converter, called the miniWEC, is being built that will allow heave plates of larger size (60-in diameter) to be tested in random waves. The effect of both scaling and wave-field randomness on hydrodynamic behavior will be investigated.

4.1 Design

The miniWEC is a 72-in diameter floating point absorber that uses the rotation of a spindle to produce power. The heave plate tether is wrapped around the spindle, thus imparting a moment that is opposed by a counter moment from a bank of extension springs. The weight of the heave plate causes the springs to stretch to an equilibrium point. The incident waves induce motion in the float which causes the spindle to oscillate about the equilibrium point. In initial tests, power will be dissipated using a rotary dashpot attached to the spindle shaft. The torque curve of the dashpot is similar to a gearbox and generator. Once the system is proven, a gearbox, generator, and control system will be added to the miniWEC for testing in 2017.

The miniWEC will be instrumented such that the hydrodynamic coefficients of the heave plates may be calculated in random wind driven waves. The miniWEC will measure and log the float orientation and acceleration, heave plate tether tension, return spring tension, spindle position, and waterline position simultaneously at 50-hz. The data acquisition uses a National Instruments compactRIO. A wireless network will be used to communicate with the miniWEC during operation. The

wireless communications will primarily be used for system fault monitoring, but may also allow for redundant remote data-logging on-board a nearby vessel.

A stand-alone data-logging inertial measurement unit will record the motion of the heave plates. The flow past the heave plate will be measured with a Nortek ADV. Both measurements will be recorded at 50-hz.

The miniWEC will test two 60-in diameter heave plates. The first will be a standard flat plate, and the second will be the 45° hexagonal conic shown in Figure 5. The hexagonal shape is an easy to manufacture approximation of the circular conics tested on the oscillator. In future work, small 12-in diameter hexagonal conics will be tested on the Oscillator in order to ensure geometric similarity between the heave plate scales.

4.2 Test Plan

In early April, 2016, the miniWEC will be deployed on Lake Washington, near the University of Washington campus. Strong winds on the lake are capable of producing fetch limited waves with a significant wave height of 0.5-m and an energy period of 3-s. The University of Washington Applied Physic Lab's R/V Jack Robertson will be used to deploy and monitor the miniWEC during operation. The miniWEC will be released up-wind and allowed to freely drift down-wind (usually South to North). This will allow the system to operate in a range of wave conditions as it moves through the wave fetch over the course of a day of testing. Free drifting wave measurement buoys (SWIFT Drifters) will be deployed around the miniWEC to record the incident wave field [10].

Each heave plate will be tested for a full day, at which point the system will be recovered, the heave plates will be swapped, and the system will be made ready for testing on a subsequent day. As previously mentioned, the dashpot will be replaced with a generator and control

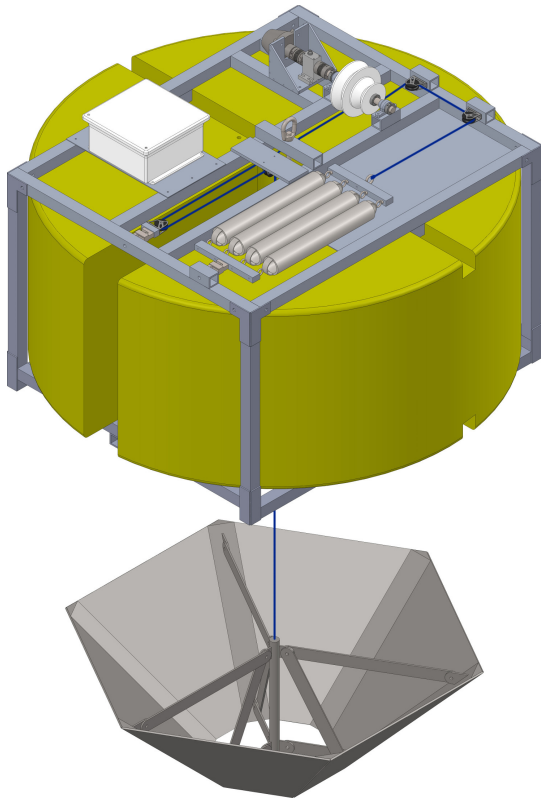

Figure 5: The miniWEC is a floating point absorber that uses the rotation of a spring loaded spindle to produce power. A heave plate is tethered to the spindle opposing the springs such that the motion of the waves causes the spindle to oscillate around the equilibrium point.

system for testing the following winter (2017).

5. CONCLUSIONS

The Oscillator has allowed the hydrodynamic performance of several different heave plate geometries to be examined. The data shows that constant coefficient Morison Equation approximations of heave plate loading provide a reasonable initial estimate. However, constant coefficient estimates tend to miss the maxima and minima of the loading. A full characterization of hydrodynamic performance must consider the flow induced in the water by the heave plate, and allow for coefficient variability.

A small wave energy converter, called the miniWEC, is being developed to test heave plates at a much larger scale than can be tested on the Oscillator. Deployments of the miniWEC will occur in March. The effect of wave randomness, and the proper scaling of hydrodynamic coefficients with physical size will be investigated through comparison of the two data sets.

6. ACKNOWLEDGEMENTS

This work is funded through a contract with Naval Facilities Engineering Command (NavFac). I would also like to thank Dylan Dubuque for his work on the Oscil-

lator.

7. REFERENCES

- [1] Falnes, J., 2007. "A review of wave-energy extraction". *Marine Structures*, **20**(4), Oct., pp. 185–201.
- [2] Ruehl, K., Michelen, C., Kanner, S., Lawson, M., and Yu, Y.-H., 2014. "Preliminary Verification and Validation of WEC-Sim, an Open-Source Wave Energy Converter Design Tool". In ASME 2014 33rd International Conference on Ocean, Offshore and Arctic Engineering, American Society of Mechanical Engineers, pp. V09BT09A040–V09BT09A040.
- [3] Thiagarajan, K. P., Datta, I., Ran, A. Z., Tao, L., and Halkyard, J. E., 2002. "Influence of Heave Plate Geometry on the Heave Response of Classic Spars". pp. 621–627.
- [4] Tao, L., Molin, B., Scolan, Y. M., and Thiagarajan, K., 2007. "Spacing effects on hydrodynamics of heave plates on offshore structures". *Journal of Fluids and Structures*, **23**(8), Nov., pp. 1119–1136.
- [5] Mundon, T. R., and Nair, B., 2014. "Optimization of a magnetostrictive wave energy converter". In GRAND RENEWABLE ENERGY 2014 Proceedings.
- [6] Tao, L., and Thiagarajan, K., 2003. "Low KC flow regimes of oscillating sharp edges I. Vortex shedding observation". *Applied Ocean Research*, **25**(1), Feb., pp. 21–35.
- [7] Li, J., Liu, S., Zhao, M., and Teng, B., 2013. "Experimental investigation of the hydrodynamic characteristics of heave plates using forced oscillation". *Ocean Engineering*, **66**, July, pp. 82–91.
- [8] An, S., and Faltinsen, O. M., 2013. "An experimental and numerical study of heave added mass and damping of horizontally submerged and perforated rectangular plates". *Journal of Fluids and Structures*, **39**, pp. 87–101.
- [9] Brown, A. C., and Thomson, J., 2015. "Heave Plate Dynamics for a Point Absorbing Wave Energy Converter". In Proceedings of the 3rd Marine Energy Technology Symposium.
- [10] Thomson, J., 2012. "Wave Breaking Dissipation Observed with "SWIFT" Drifters". *Journal of Atmospheric & Oceanic Technology*, **29**(12), Dec., pp. 1866–1882.