

Asia Pacific Research Initiative for Sustainable Energy Systems 2011 (APRISES11)

Office of Naval Research
Grant Award Number N0014-12-1-0496

Wave Energy Grid Interconnection at the Navy's WETS 30m Project Site

Task 4.2

Prepared For
Hawaii Natural Energy Institute

Prepared By
Northwest Energy Innovations

June 2014



**NWEI Wave Energy Grid
Interconnection at the Navy's
WETS 30m Project Site**

2014

Technical Report



Northwest Energy Innovations

6/5/2014

This page intentionally left blank.

TABLE OF CONTENTS

1. Introduction	4
2. Description of the NWEI Device.....	4
2.1. General arrangement.....	4
2.2. Hydraulic and electrical power generation system	6
2.3. Control and data acquisition.....	7
3. Description of the Existing 30m WETS Site Grid Interconnection Infrastructure	7
4. Assessment of Grid Interconnection Options at 30m WETS Site	9
4. NWEI Grid Interconnection System for the 30m WETS Site	13
4.1. Inverters and associated components.....	14
4.2. Effects of device to shore cable resistance, inductance, and capacitance on the system	18
4.3. Ancillary power system.....	19
4.4. Control and data acquisition.....	20
4.5. HECO grid interconnection application.....	21
5. NWEI Umbilical Cable, Subsea Junction Box, and Bend Restrictors	22
5.1. Umbilical Cable	24
5.2. Subsea J-box.....	25
5.3. Termination of Umbilical to NWEI Device	26
5.4. T-Plate	28
APPENDICES	29
GLOSSARY OF TERMS & ACRONYMS	30

1. INTRODUCTION

Northwest Energy Innovations (NWEI), Naval Facilities Engineering Command's Expeditionary Warfare Center (NAVFAC/EXWC), University of Hawaii's Hawaii National Marine Renewable Energy Center (HNMREC) and the U.S. Department of Energy's National Renewable Energy Laboratory (NREL) are working collaboratively to deploy and test NWEI's half-scale multi-mode wave energy converter (NWEI Device). These tests will take place at the NAVFAC and HNMREC 30-meter Wave Energy Test Site (WETS) at the Kaneohe Marine Corps Base Hawai'i (MCBH) on the windward (northeast) coast of the island of O'ahu. The site is located northeast of Hee'i'a Kea Small Boat Harbor and is within the security zone of MCBH. The WETS 30m Site was engineered and installed as part of a previous wave energy program. As described in the Site Report¹ (Appendix A), it is grid connected to MCBH through terrestrial and subsea cables that begin at the control room in Battery French and terminate offshore at the 30m Site. These cables will be used during deployment of the NWEI device, however, because of differences between the NWEI device and the device previously deployed at the WETS 30m site, NWEI can't use most of the grid interconnection, control, and monitoring equipment remaining at Battery French from the previous project and will install its own equipment. Also, the umbilical cable system used to connect the device is not available from the previous wave energy project, so new equipment will be provided by NWEI. This report describes the existing equipment at the 30m WETS, an assessment of grid interconnection options for the site, and a description of the equipment that NWEI plans to install at the site.

2. DESCRIPTION OF THE NWEI DEVICE

The NWEI Device that will be deployed at WETS is a half-scale multi-mode, point absorber wave energy convertor based on the WET-NZ design.

2.1. General arrangement

A photo of the half-scale NWEI device at sea during a previous deployment in Oregon is shown in Figure 1, together with a solid model rendering of the device and its power takeoff (PTO) system. Characteristics of the device are listed in Table 1. The device is half-scale by length; output power scaling per the Froude similitude criteria is 1/11 relative to a nominal full scale device. The device consists of a long submerged hull, with a power pod mounted on top that includes a cylindrical float and the power take-off system.

The float of the NWEI device is coupled through its shaft to the power-takeoff (PTO) system and rotates up and down in the waves to generate power. The device is designed to be slack-moored and self-reacting; the hull is flooded with seawater to give it a large inertia for the float to react against. The natural period of the half-scale spar, which consists of the entire device other than the float, is 15 seconds, and the natural period of the half-scale float is 3.5 seconds. Due to these natural periods,

¹ 30-meter Site Report, NAVFAC, November 10 2013

simulations predict that the half-scale device will not generate significant power for portions of the wave spectra with periods longer than approximately 9 seconds. A full-scale device, however, is expected to have longer natural periods and to produce power from longer period waves.

The PTO for the NWEI device is shown on the right side of Figure 1. A crankshaft that connects to the shaft of the float extends and retracts hydraulic cylinders. The system uses two sets of crankshafts and hydraulic cylinders on opposite sides of the float. The hydraulic cylinders provide pressure to a hydraulic system that drives an electric generator, described in Section 2.2.

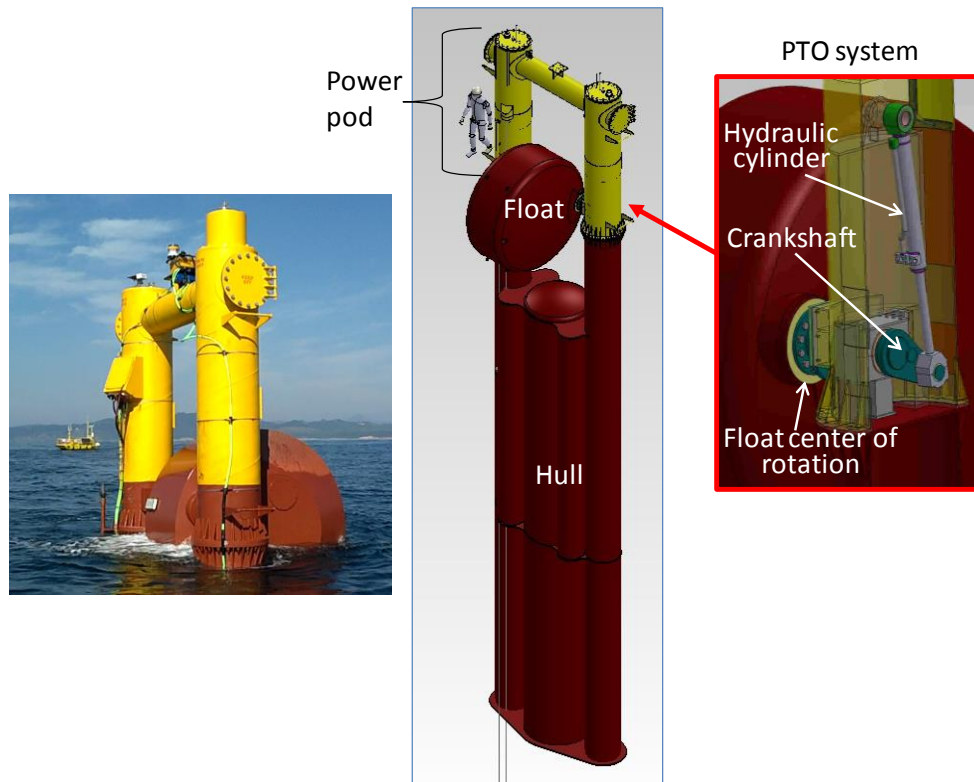

Figure 1 Half-scale NWEI Device

Table 1 Half-scale NWEI Device Characteristics

Length scaling ratio*	1/2
Power scaling ratio (Froude)*	1/11
Average Power	6 kW
Peak power	20 kW
Draft	15 m
Spar natural period	15 s
Float natural period	3.5 s

*Relative to full-scale device

2.2. Hydraulic and electrical power generation system

The hydraulic and electrical power generation system shown in Figure 2 is used to convert hydraulic power in the two hydraulic cylinders to electrical power on board the half-scale NWEI device. Hydraulic flow from the two cylinders, rectified by a set of valves, rotates a variable displacement hydraulic motor that is coupled to an electrical generator. When an electrical load is applied to the generator, a corresponding torque is applied to the hydraulic motor shaft that in turn creates hydraulic pressure in the motor and the rest of the hydraulic system. That pressure causes the hydraulic cylinders to apply force to the float through the crankshaft shown to the right side of Figure 1. The hydraulic system also includes pressure limiting valves, a reservoir, accumulator, filter, an overspeed valve, and other minor components that are not shown in Figure 2.

The electrical output of the half-scale NWEI device generator is three phase, variable frequency and voltage. A power converter, not included in the half-scale design, is necessary to convert this variable frequency and voltage generator output to 60 Hz for a grid connection. While a full-scale device will include this power converter on board, the half-scale device is a prototype that was not designed to be grid-connected so does not include this equipment; during the previous deployment of this device a stand-alone electrical resistance load was connected directly to the generator output. Additional power conversion equipment, both on board the device and on shore, was developed by NWEI for the grid-connected deployment at the 30m WETS site. This equipment is described in Section 4.

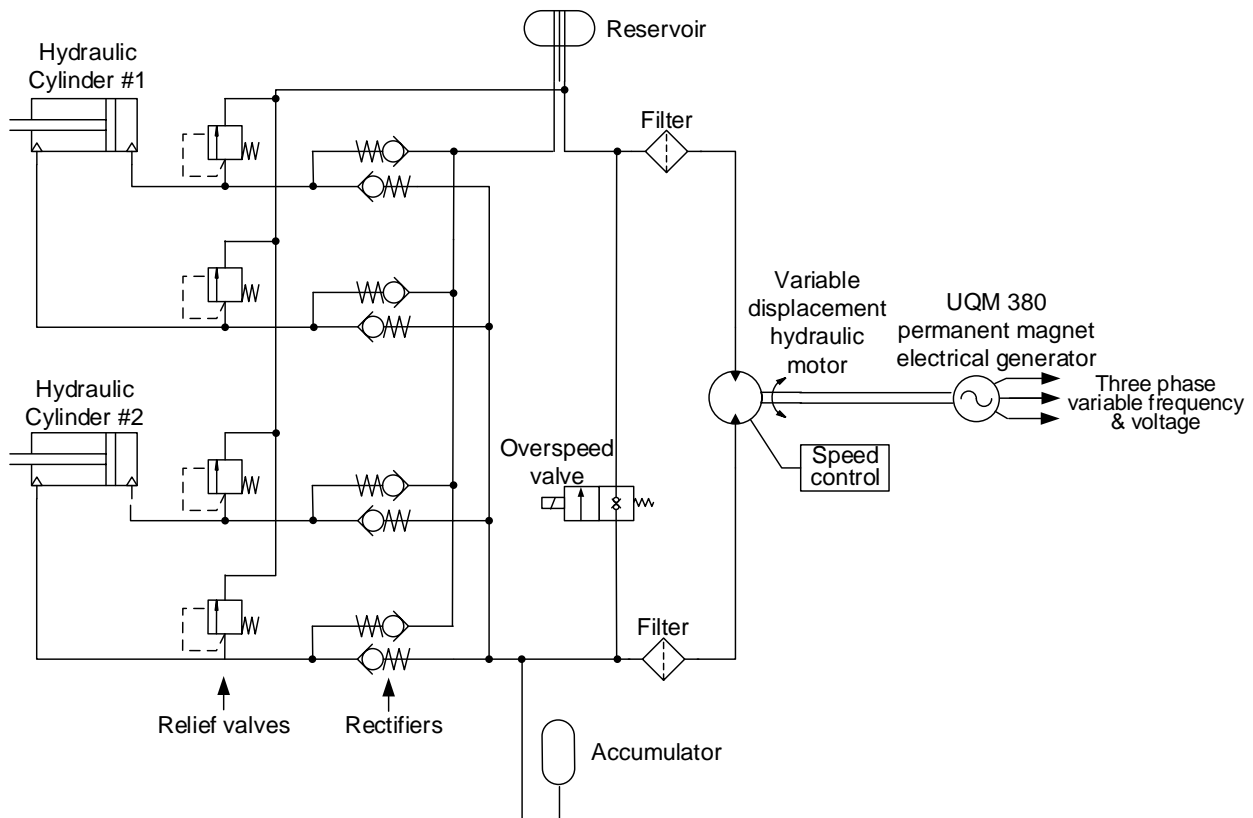

Figure 2 Half-scale NWEI device hydraulic and electrical power generation system

2.3. Control and data acquisition

Control and data acquisition systems installed on board the half-scale NWEI device are shown in Figure 3. Control of the hydraulic motor shown in Figure 2 as well as data collection from instrumentation on board the device is provided by a National Instruments CompactRIO controller with software developed by NWEI. In addition, a separate data system developed by the National Renewable Energy Laboratory (NREL) will be installed on board the device to collect data from secondary instrumentation. Communications between both the NWEI CompactRIO controller and the NREL data system and shore will be via Ethernet over fiber conductors in the umbilical, subsea, and terrestrial cables described in Section 3. All on board instrumentation equipment will be powered from a 24 V dc power supply. Input power for this 24V supply was provided by on board power generation and batteries in the initial design of the half-scale NWEI device. This ancillary power generation caused substantial loading on the PTO, however, which degraded device performance during the previous deployment in Oregon, so ancillary power from shore will be used for the 30m WETS deployment. Power from a 220 V dc power source on shore in Battery French will be used for this purpose, connected to the device through copper conductors in the umbilical, subsea, and terrestrial cables.

In addition, NREL will install a Nortek Acoustic Wave and Current profiler (AWAC) on the seafloor near the device. Power for the AWAC will be provided from the 24 V power supply on board the NWEI device via copper conductors in the umbilical cable. Communications between the AWAC and shore will be via serial over optical fibers in the subsea and terrestrial cables to shore.

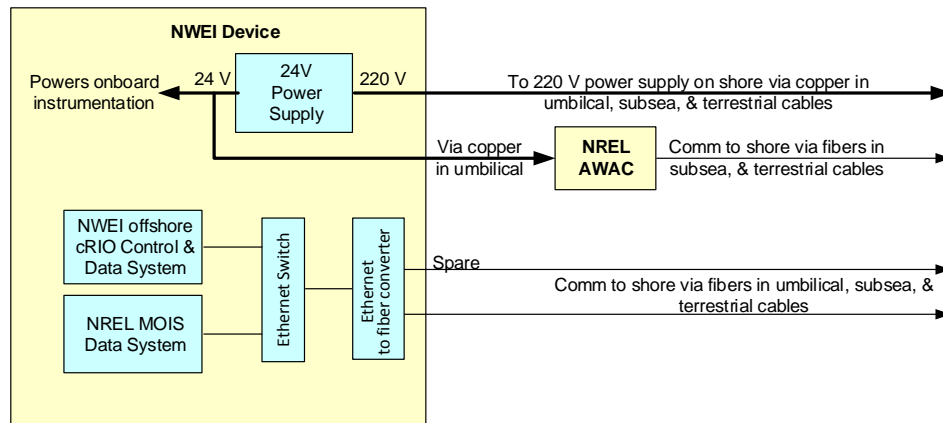

Figure 3 Control and data acquisition equipment on board half-scale NWEI device

3. DESCRIPTION OF THE EXISTING 30M WETS SITE GRID INTERCONNECTION INFRASTRUCTURE

The WETS 30m site was engineered and installed as part of a previous wave energy program. See the Site Report (Appendix A) for a detailed description of the 30m site infrastructure. The existing cabling at the site is shown in Figure 4. The grid connection is located in Battery French (Building 614); from there a terrestrial cable and subsea cable runs to the location of a previously deployed transformer pod (T-Pod) on the sea floor. The T-Pod, used for the previous program, is a 45 kVA, 208V:4160V, three phase

60 Hz transformer in an air-filled, sealed subsea chamber that is available for re-deployment. An umbilical cable is used to connect the WEC being tested to the subsea cable at either the T-Pod or a substitute subsea junction box if the T-Pod is not reused. The umbilical used during the previous program is not available for re-use, so providing this umbilical is the responsibility of the WEC developer. The specifications for the subsea and terrestrial cables are listed in Table 2.

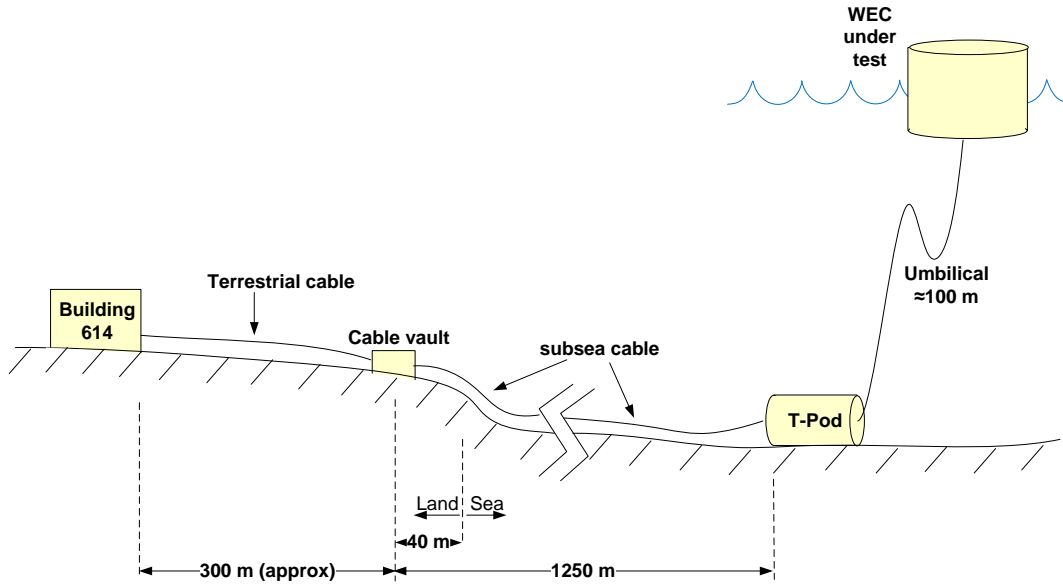

Figure 4 Existing subsea and terrestrial cable system at 30 m WETS

Table 2 WETS 30m Cable Specifications

Cable	Umbilical*	Subsea	Terrestrial
Length	Approx 100m	1250 m	300 m (approx)
Power conductors	6 AWG	3 x 16 mm ² (6 AWG)	6 AWG
Electrical resistance	0.42 Ω	1.49 Ω	0.42 Ω
Electrical inductance**	0.1 mHy	0.9 mHy	0.2 mHy
Electrical capacitance***	0.02 μF	0.3 μF	0.07 μF
Optical fibers		4x single mode	≥4 single mode

* Rough estimate of umbilical; specific design is responsibility of each developer at WETS.

** Cable inductances are rough estimates based on cable geometry.

*** Cable capacitances estimated using 0.23 μF from subsea cable manufacturer for all cables

A simplified one-line diagram of the WEC power generation and grid interconnection system that was used for the previous wave energy program at the WETS 30m site is shown in Figure 5. The terrestrial and subsea cables and existing equipment at the WETS 30m site were designed for this power system. An ac generator was used on board the device to produce variable voltage and frequency (“wild frequency”) three phase power. An onboard power converter was used to convert this wild frequency

power to 208 Vac, 60 Hz, three phase power. Although the details of this power converter design are proprietary to the WEC developer, typically back to back converters are used, the first to convert wild frequency ac to dc, and the second to convert dc to 60 Hz ac. Power was transmitted from the device to the T-Pod on the seafloor via a short umbilical cable at 208 Vac. A transformer inside the T-Pod then stepped voltage up to 4160 V for transmission to shore over the longer subsea and terrestrial cables. A second transformer inside Battery French stepped voltage back down to 220 Vac for the utility grid connection. This system allows power to be transmitted over the long subsea and terrestrial cables at medium voltage (4160 V), which reduces cable current and also voltage drops in the cables due to inductance, capacitance, and resistance compared to lower voltage transmission.

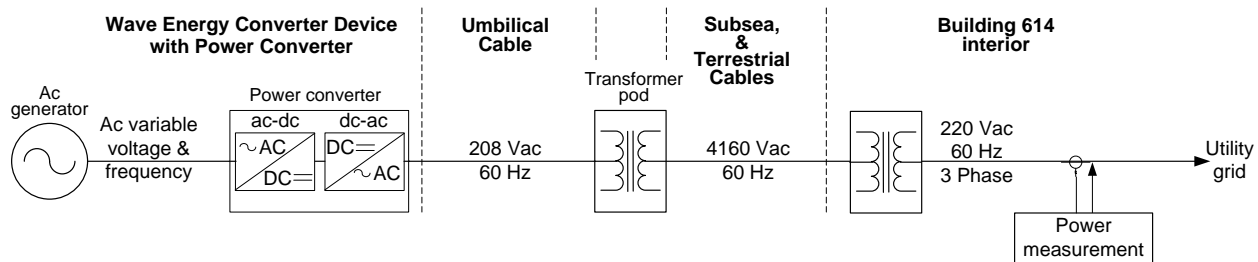

Figure 5 Simplified One Line Diagram for Previous Test at 30m WETS Site

4. ASSESSMENT OF GRID INTERCONNECTION OPTIONS AT 30M WETS SITE

NWEI initially considered the three different grid interconnection architectures for the half-scale NWEI device at the 30m WETS site. These three alternate architectures, shown in Figure 6, are described below.

1. **60 Hz medium voltage** – This is the architecture that was used in for previous wave energy project at the 30m WETS site and described in the previous section. It requires a power converter on board the wave energy device to convert the variable voltage and frequency output of the generator to low voltage 60 Hz. Step-up and step-down transformers in the T-Pod and bunker on shore increase voltage and decrease current in the cables to shore in order to reduce cable losses. Since the three phase power connection to shore is at fixed voltage, this voltage is always present and can be used to supply ancillary power to the device being tested from shore.
2. **Low voltage ac, variable frequency and voltage** – This is a simple architecture where the variable voltage and frequency output of the generator on board the device is connected directly to shore through the umbilical, subsea, and terrestrial cables. A power converter on shore is used to convert the variable ac to 60 Hz ac necessary for grid interconnection. The voltage and frequency range used for power transmission to shore is determined by the rotational speed and design of the generator on board the device being tested. In the case of the NWEI device, the output voltage of the generator is approximately 0-400 V and the frequency can be as high as 600 Hz. Connection of the three phase generator output to shore requires the use of the three conductors in the existing subsea and terrestrial cables described in Section 3. Because generator output voltage varies in

proportion to generator speed, when generator speed goes to zero, voltage goes to zero. This makes the transmission of ancillary power from shore to the device using the three power conductors in the subsea cable impractical using this architecture. The T-Pod transformer is not used for this architecture, so the junction between the umbilical and subsea cable can be at a simple subsea junction box rather than at the T-Pod.

- Low voltage dc, variable voltage** – This architecture uses a passive, three phase rectifier on board the device being tested to convert the permanent magnet (PM) ac generator output to dc for transmission to shore. Passive rectification is only possible for WEC designs that use a PM generator, and is not possible for asynchronous (induction) generators. The NWEI device uses a PM generator. In this system the dc voltage varies with the ac generator voltage, but is approximately 30% higher than the ac line-line, rms generator voltage due to rectification. The dc voltage range is dependent on the rotational speed and design of the generator on board the device being tested; for the half-scale NWEI device it will be approximately 0-525 V. Connection of the dc voltage to shore requires two of the three conductors in the existing subsea and terrestrial cables. Because the dc voltage will be in proportion to generator speed, voltage will go to zero when generator speed goes to zero and it is not practical to transmit ancillary power from shore to the device using this dc voltage. The dc power transmission only requires two conductors, however, leaving one of the three conductors in the existing 30m WETS subsea and terrestrial cables available for a separate ancillary power system. The T-Pod transformer is not used for this architecture, so the junction between the umbilical and subsea cable can be at a simple subsea junction box rather than at the T-Pod.

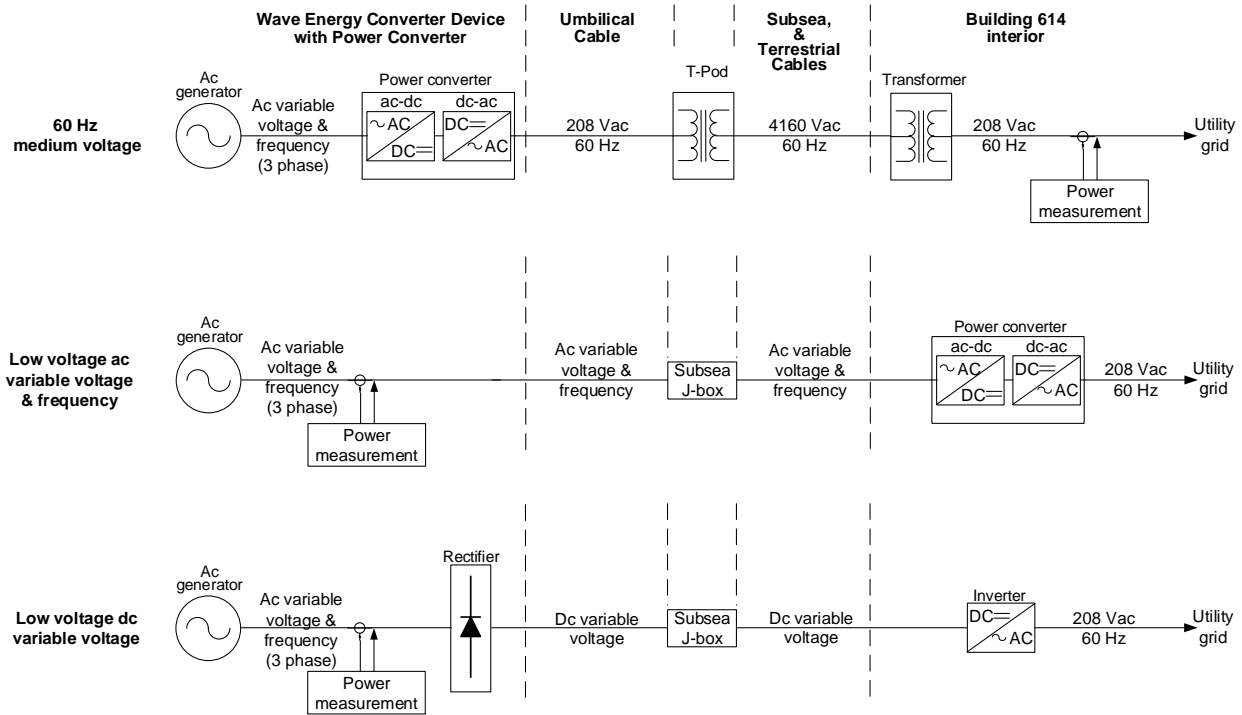

Figure 6 Grid interconnection architectures considered by NWEI for 30m WETS site

The descriptions of the alternate grid interconnection architectures above assume that electrical power is generated on board the wave energy converter using a three phase generator that rotates at variable speed, so that its output has a variable frequency and variable voltage. This is the case for the half-scale NWEI device and is expected to be the case for most other wave energy converter designs that will be installed at the 30m WETS site.

The option of transmitting low voltage, 60 Hz power to shore by eliminating the two transformers in the first architecture was not considered for the NWEI device. The step-up and step-down transformers in the transformer pod and bunker already exist for the 30m WETS site and it is expected that they would be used to step up voltage and reduce cable losses for 60 Hz power transmission.

Transmission of power to shore using low voltage, either ac or dc, will likely cause significant power losses in the cables to shore and is only practical for lower power devices. It is expected that these methods will only be used for low power prototypes being tested at the 30m site such as the half-scale NWEI device, where the purpose of the deployment is to assess the device itself rather than the grid interconnection architecture. The amount of power loss in the cables to shore will depend on the specific output voltage and power of the device being tested. Due to the power losses in the cable, it is assumed that output power from the device will be measured on board the device rather on shore when low voltage ac or dc power transmission is used, in order to directly assess the device performance independent of cable losses.

The advantages and disadvantages of the three grid interconnection options that are shown in Figure 6 are listed in Table 3. The 60 Hz medium voltage architecture is the best option when a power converter is installed on board the device. This architecture minimizes losses in the cables to shore and also allows ancillary power to be transferred to shore with the fixed ac voltage, using the three conductors in the existing subsea and terrestrial cables at the 30m WETS site. The half-scale NWEI device does not have a power converter on board, however, and designing and installing one for the 30m WETS deployment would be a significant task. This made the 60 Hz medium voltage architecture not feasible for the NWEI device.

The low voltage ac architecture with variable voltage and frequency has the advantage of simplicity, and does not require a power converter on board the device. It has two significant disadvantages for the NWEI device, however: 1) since the half-scale NWEI generator has a relatively high output frequency up to 600 Hz, inductive voltage drops in the subsea and terrestrial cables would be large, and 2) ancillary power transfer to shore isn't possible. This option would be feasible when low power devices are tested that can supply their own ancillary power. The half-scale NWEI device requires ancillary power from shore.

The low voltage dc architecture with variable voltage has two significant advantages over the low voltage ac architecture: 1) dc transmission eliminates inductive and capacitive voltage drops in the cable, and 2) only two conductors are required for power transmission, leaving the third conductor free for ancillary power transmission from shore to the device. Although a three phase rectifier is required on board the device, passive rectifiers are quite small and relatively simple to install. The most significant disadvantage of this architecture is the resistive losses in the cable to shore. These depend

on the output voltage and power of the generator on board the device. NWEI selected this architecture for its device because a power converter is not needed on board and it allows transfer of ancillary power from shore to the device. NWEI assessed the resistive voltage losses in the cables to shore and found that although cable losses will be significant, operation of the device is not expected to be significantly compromised.

Table 3 Comparison of interconnection options

Architecture	Pros	Cons
60 Hz medium voltage	<ul style="list-style-type: none"> • Low inductive/capacitive voltage drops and resistive losses in cable to shore at medium voltage. • Ancillary power transmission from shore to device possible. 	<ul style="list-style-type: none"> • Power converter required on board device.
Low voltage ac Variable voltage & frequency	<ul style="list-style-type: none"> • Power converter not required on board device. 	<ul style="list-style-type: none"> • Inductive and capacitive voltage drops in cable to shore. • Resistive losses in cable to shore. • Ancillary power transmission from shore to device not possible.
Low voltage dc Variable voltage	<ul style="list-style-type: none"> • Power converter not required on board device. • No inductive/capacitive voltage drops in cable to shore with dc. • Ancillary power transmission from shore to device possible. • Diode bridge simple to install on board device 	<ul style="list-style-type: none"> • Resistive losses in cable to shore.

4. NWEI GRID INTERCONNECTION SYSTEM FOR THE 30M WETS SITE

A diagram of the half-scale NWEI grid interconnection system that has been designed for the 30m WETS site is shown in Figure 7. Detailed electrical schematics for the NWEI equipment being installed in the WETS bunker are included in Appendix B. The variable frequency, variable voltage output of the electrical generator on board the device is connected to a 1.5:1 “boost” transformer that increases output voltage by 50% in order to increase voltage and decrease current in the subsea cable and reduce resistive losses. This boost transformer was added to the half-scale NWEI device after analyzing the effects of cable resistance on the system. The output of the boost transformer is connected to a three phase diode bridge rectifier on board the device through a set of three contactors. These contactors can be opened by the onboard control system to disconnect the generator from the rest of the interconnection system when faults occur. The diode bridge rectifies the three phase ac generator output to produce a variable dc voltage that ranges from zero to 525V and is transmitted to shore via the umbilical, subsea, and terrestrial cables.

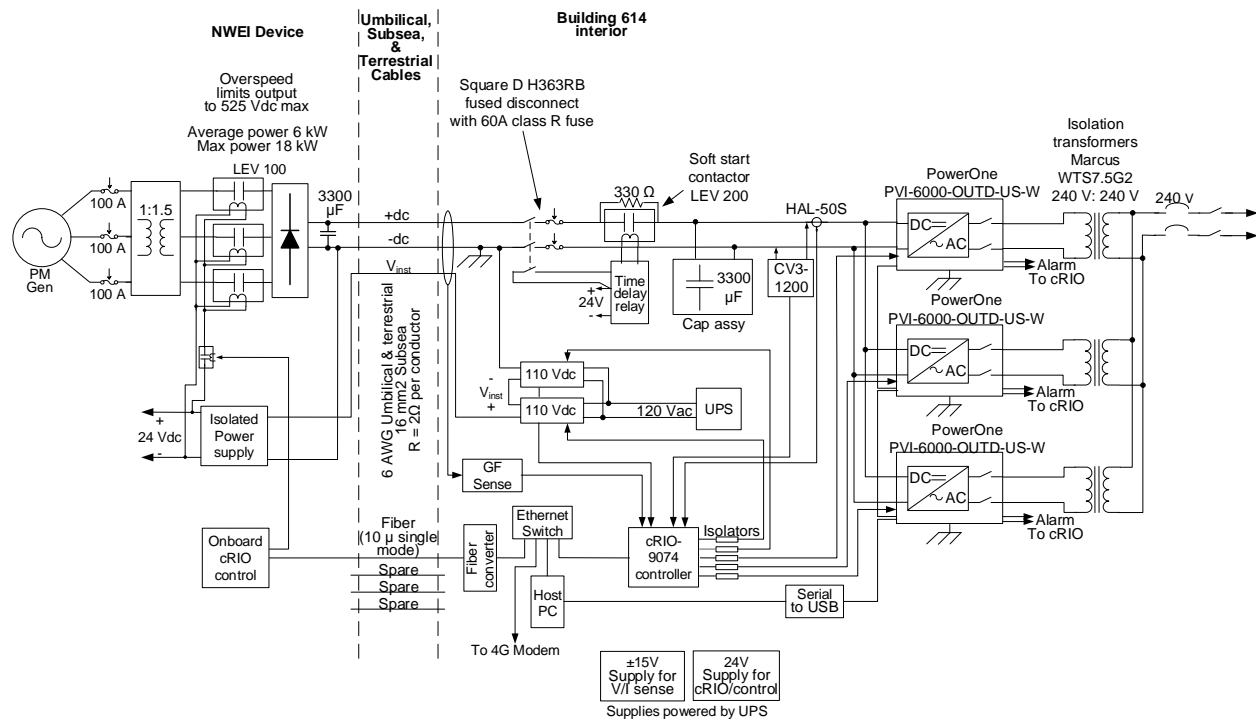

Figure 7 Grid Interconnection System for Half-scale NWEI Device at 30m WETS Site

On shore, the dc outputs from the device are connected to a fused disconnect; when opened this disconnects the device from the rest of the interconnection equipment. The shore side of the fused disconnect is connected to a 3300 µF capacitor bank through a soft start contactor, then to three, parallel 6 kVA grid interconnect inverters. The three parallel inverters are required to provide sufficient capacity (18 kVA) to process the peak output power of the device. The inverters require the 3300 µF capacitor banks at their dc inputs to stabilize voltage per the manufacturer’s instructions, and isolation transformers at their ac outputs. The soft start contactor is necessary to slowly charge up the capacitors

through a parallel resistor when the fused disconnect is closed while there is dc voltage on the subsea cable; a time delay relay is used to control this contactor. Two National instruments CompactRIO controllers, one on board the device and one on shore, are used to control the system and to collect data. The onshore controller is used to control the inverters per a control signal from the onboard controller. The output of the inverters is connected to one phase of the 208 V, 150 kVA transformer outside the bunker through a disconnect switch.

Ancillary power for the half-scale NWEI device is provided by two 110 V dc power supplies in the bunker; the series connection of these two supplies gives 220 V dc that is connected to the device. The combined power supplies have over 1000 W capability, although typical power usage on board the device is expected to be 400 W or less. The 220V dc power is connected to the device through the third conductor of the umbilical, subsea, and terrestrial cables; the 220 V dc return is in common with the negative dc conductor that is used for power transmission. The 220V dc ancillary power is converted to 24V on board the device to power instrumentation and other equipment. Due to resistive voltages in negative dc conductor between the device and shore that add to the 220V power supply output, the ancillary voltage at the device itself can be much higher than 220V depending on the output power of the device. The 24V power supply on board the device is designed for a wide range of input voltages for this reason.

NWEI has also included an independent ground fault sensing system to detect when a ground fault has occurred on board the NWEI device. This system uses a Bender RCMA 423 ground fault module. Detailed connections are shown in Appendix B. This system uses a current sensor to measure the sum of currents in the three conductors of the terrestrial cable; when the sum of currents is not equal to zero a fault is detected and the inverters are shut off through the NWEI CompactRIO control system. Ground faults can cause safety issues and can also cause high rates of device hull corrosion when electrical current flows through the hull to seawater.

4.1. Inverters and associated components

As shown in Figure 7, NWEI will use three, parallel PowerOne part number PVI-6000-OUTD-US-W, 6 kW inverters to convert the 0-525 V dc power transmitted to shore to 208 V, 60 Hz ac power for grid interconnection. These inverters have two primary functions in the NWEI system:

1. They control the torque of the electric generator on board the half-scale device by controlling generator current
2. They convert dc power to 60 Hz ac power at 208 V for the grid interconnection

During operation of the NWEI device, generator torque may need to change from zero to maximum during each half wave cycle of the ocean waves, or as fast as every 3 seconds. The inverter must be capable of current control at this rate. In addition, the NWEI half-scale device is expected to have a peak output power of approximately 20 kW, so this capability is required of the inverters used in this system. The PowerOne inverters are off-the-shelf inverters designed to interconnect small wind turbines; they were selected by NWEI because they have the correct ac and dc voltage ranges, have

sufficient control capability, multiple devices can be operated in parallel to meet the power requirements, and they are UL 1741 certified. A photo of the PowerOne inverter is shown in Figure 8 and specifications are listed in Table 4.



Figure 8 PowerOne PVI-6000-OUTD-US-W inverter

Table 4 PowerOne PVI-6000-OUTD-US-W inverter specifications

Absolute maximum dc input voltage	600 V
Operating dc input voltage range	50-580 V
Dc input voltage range at full power	150 – 530 V
Maximum dc input current	36 A
Rated grid ac voltage	208 V/240 V/277 V selectable
Maximum output ac current	30 A/28 A/24 A
Rated frequency	60 Hz
Nominal power factor	>0.995
Total harmonic distortion	<2%
Maximum efficiency	97%
Anti-islanding protection	Per UL 1741/IEEE 1547

Hawaiian Electric Company (HECO) requires UL 1741 certification of inverters used for grid interconnection, as described in Section 4.5. Inverters that are UL 1741 certified have anti-islanding protection that turns them off within a short period of a power failure on the electric grid. UL 1741 certification is an involved process, and only a limited number of inverters were available at the time that NWEI was designing its system in 2013. Due to time and cost constraints, it was not feasible for NWEI to develop a custom inverter and have it UL 1741 certified. Before selecting the PowerOne inverter, NWEI searched through all available UL 1741 certified inverters to find one with sufficient generator control capability. Most UL 1741 certified inverters are designed to interconnect solar panels. Solar inverters are only capable of relatively slow control and can't be used with the NWEI system. A

small number of UL 1741 certified inverters in the size range needed are available for small wind turbine applications, however, and small wind turbines usually use similar generator systems to that used in the half-scale NWEI WEC. Generator torque must be controlled in small wind turbines quickly enough to respond to changes in wind velocity, similar to generator torque control requirements for the NWEI WEC. Most small wind inverters operate with a power versus voltage curve that can be programmed; inverter power is adjusted per input voltage. This method works because input voltage changes in proportion to speed of the generator. Controlling the NWEI generator using a power versus voltage curve is not feasible, however, because resistive voltages in the umbilical, subsea, and terrestrial cables cause the voltage at the inverter input to be different than the generator output voltage. The PowerOne inverter was unique among the UL certified wind inverters that were available because it has two control modes that can be selected: 1) control per a power versus voltage curve similar to other inverters, and 2) control per power versus frequency curve using a pulse control input that normally is used to measure wind turbine generator speed. After consultation with PowerOne engineers, NWEI determined that the pulse control input to the PowerOne inverter can be used to control NWEI's generator. See Section 4.4 for further details. The PowerOne inverter is not available with power capability higher than 6 kW, but multiple inverters can be operated in parallel; NWEI decided to use three parallel inverters for 18 kW peak power capacity.

A block diagram of the 6 kW PowerOne inverter is shown in Figure 9. This is a two stage inverter; two input stages, normally connected in parallel, boost input voltage and control dc current, and an output stage does the dc to ac inversion. The two power stages are controlled by a flexible control circuit that can be configured using a control panel on the device itself or using a PC connected to the device through an RS-485 interface. Alarm relay outputs indicate when fault conditions exist. This inverter is designed to be used together with a PowerOne "wind box" that is connected between the three phase output of a permanent magnet generator in a small wind turbine and the inverter. The wind box provides the following: 1) three phase rectification of the generator output, 2) a resistive dump load that switches in when necessary to limit generator speed, 3) addition of bulk capacitance to the inverter input, and 4) generation of a control pulse signal synched to the electrical frequency of the generator. NWEI is not using this wind box, but replicates its functionality with other components in the system. Referring to Figure 7, a generator rectifier is included on the device, the device hydraulics limit maximum generator speed so a resistive dump load is not needed, a 3300 μF capacitor assembly is connected to the dc side of the inverters to provide bulk capacitance, and the NWEI controller described in Section 4.4 provide a pulse input that replaces the "wind speed input" shown in Figure 9.

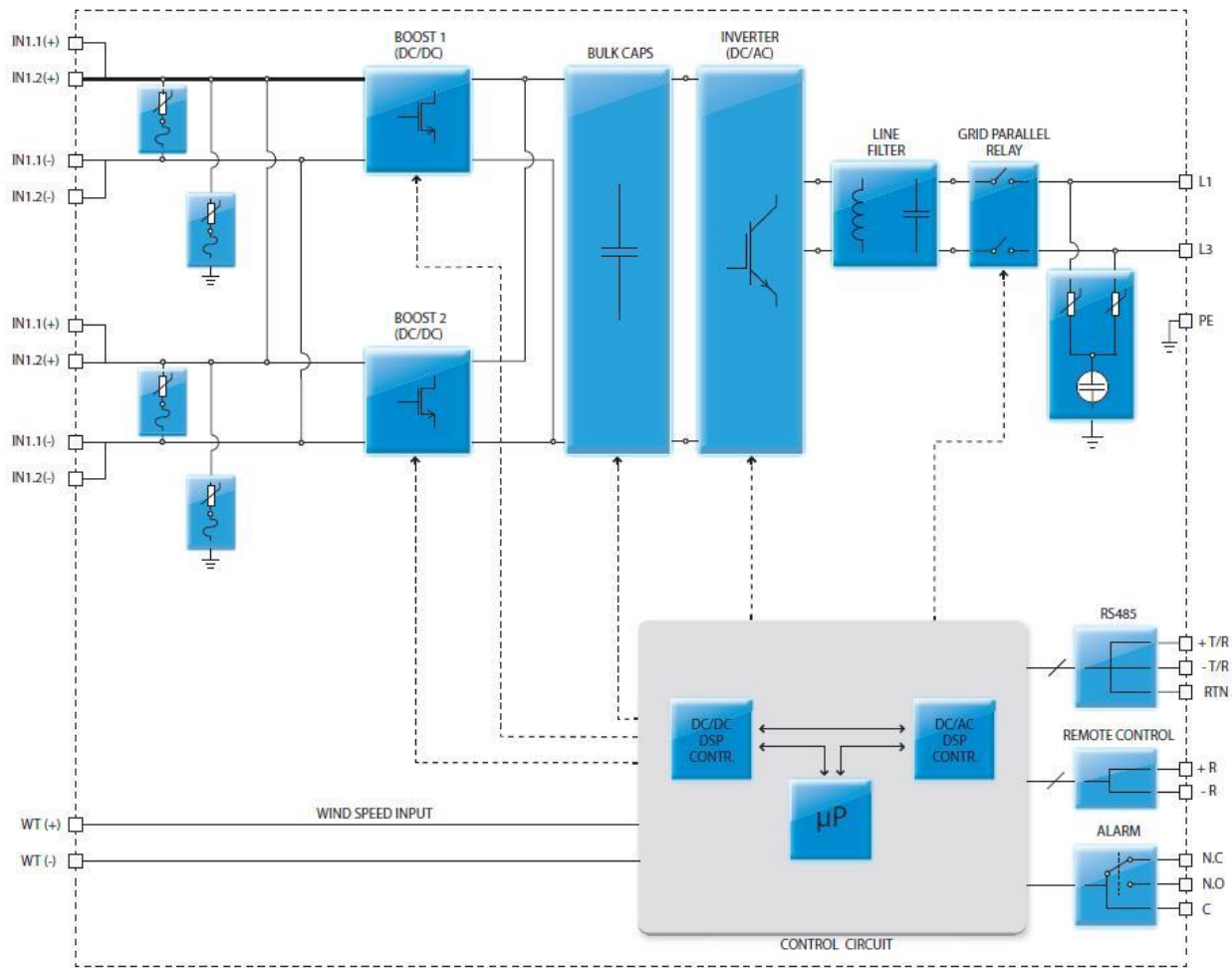

Figure 9 Block diagram of PowerOne PVI-6000-OUTD-US-W inverter

The ac outputs of the three PowerOne inverters are each connected through 208 V : 208 V isolation transformers, as shown in Figure 7. These isolation transformers serve two purposes: 1) they allow the negative dc terminals of each inverter to be connected to ground, which is necessary for the ancillary dc power supply system described in Section 0, and 2) they allow the three inverters to be connected in parallel. PowerOne recommends using isolation transformers when inverters are operated in parallel because there may be small differences between the common mode input voltages for each inverter that would cause circulating currents in the absence of these transformers. Since NWEI is using isolation transformers to connect each inverter to 208 V, it is possible to either connect the three inverters to 208 V, three phase by connecting each inverter to a different phase, or to connect all three inverters in parallel to 208 V, single phase. A single phase connection was selected because it is possible for the NWEI system to operate with only one or two of the three inverters at reduced power, which would create difficulty with the three phase power system due to imbalance. A drawing and specification for the isolation transformers is included in Appendix C. These isolation transformers were recommended

by a PowerOne distributor and are commonly used with the 6 kVA PowerOne inverters. They are rated for 240 V, 7.5 kVA and are also capable of operating at 208 V, 6 kVA.

4.2. Effects of device to shore cable resistance, inductance, and capacitance on the system

The combined umbilical, subsea, and terrestrial cables that connect the electrical generator on board the half-scale NWEI device and the PowerOne inverters in the bunker have substantial resistance, inductance, and capacitance. See Table 2 for estimated values. Because the NWEI system uses dc transmission to shore, cable resistance has more substantial effects on the system than inductance or capacitance. The combined resistance of the three cables is 2.3 Ω . It is possible for the dc output current from the half-scale device to be as high as 60 A, causing combined voltage drops in the two dc conductors as high as 140 V, although NWEI intends to operate the system at lower currents to reduce these effects. This is a large voltage between the generator and inverter in a system that has a maximum dc voltage of 525 V. The resulting effects of cable resistance on the system are as follows:

1. A substantial fraction of the power generated on board the device can be dissipated in the cable to shore relative to the ac output power of the inverter. For an accurate power assessment of the device itself, output power must be measured on board the device rather than on shore, as described in Section 4.4.
2. The dc voltage at the inverter inputs can be substantially less than the dc voltage on board the device. This makes control of the inverter via power versus voltage curves impractical. The inverters must be controlled via a signal from the controller on board the device as described in Section 4.4.
3. The voltage in the negative dc power conductor adds to the 220 V from the ancillary power supplies on shore because the negative dc power connection is used in common with the negative dc connection of the ancillary power supply. This must be taken into account in design of the ancillary power supplies on board, as described in Section 0.

Although the NWEI system uses dc power transmission to shore, a small “six pulse” ac voltage at six times generator frequency does occur at the output of the three phase diode rectifiers on board the device and is superimposed on the dc cable voltage. This voltage can interact with the inductance and capacitance in the cable to shore due to transmission line effects. These effects were investigated by NWEI using simulations of the system in MATLAB-Simulink. The results of that analysis are presented in Appendix D. The results show that high frequency voltages can occur in the cable to shore, but these voltages can be eliminated by adding large bulk capacitance (3300 μF) at the output of the diode rectifier on board the device. This capacitance, shown in Figure 7, has been added on board the device for this reason.

4.3. Ancillary power system

The NWEI system sends ancillary power from the bunker to the half-scale device using the third, otherwise unused conductor in the subsea, umbilical, and terrestrial cables. A simplified diagram of this system is shown in Figure 10. The voltage V_{inst} is the 220 V dc voltage produced by the two series 110 V dc power supplies installed in the bunker that are shown in Figure 7. The two 110 V dc power supplies in the bunker will be powered through an uninterruptable power supply (UPS) so that V_{inst} will remain present if ac power is lost in the bunker. The negative output of V_{inst} is connected to the negative dc power conductor used for dc power transmission from the generator to shore. This conductor is grounded on shore to be sure that V_{inst} doesn't float substantially above building ground. The positive output of V_{inst} is connected directly through the third conductor of the subsea cable to the positive input to a 24 V dc power supply on board. The negative input to this power supply is connected to the negative dc power conductor of the subsea cable. Due to the cable resistance effects described in Section 4.2, a voltage V_{IR} occurs in the power conductors of the cables between the device and shore; as a result, the voltage at the input to the 24 V dc power supply on board is $V_{inst} + V_{IR}$, or 220 V + V_{IR} . V_{IR} is equal to the product of the cable resistance and generator output current, and fluctuates as the output power of the device fluctuates with the ocean waves. For this reason, a 24 V power supply was installed on board the half-scale NWEI device for this deployment that can operate with this fluctuating input voltage.

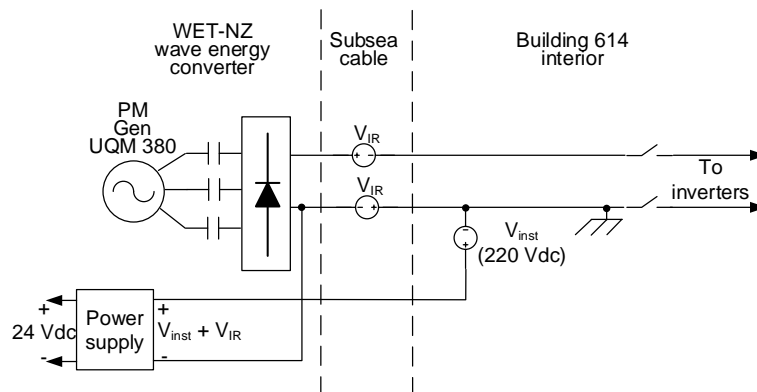

Figure 10 Ancillary power system for half-scale NWEI device

The 24 V ancillary power supply design used on board the NWEI device is shown in Figure 11. This power supply provides ancillary power to operate all instrumentation and control equipment on board the device. It was designed to produce up to 1000 W of power at 24 V dc, although actual power consumption is expected to be less than 400 W. The power supply uses three parallel Synqor dc-dc power converter modules that are designed to operate with input voltages that rapidly fluctuate between 200 V and 400 V. The transient suppressors and input capacitors were designed to stabilize these power supplies for the long cable connections to shore. Three parallel power supplies are used to add redundancy and increase reliability.

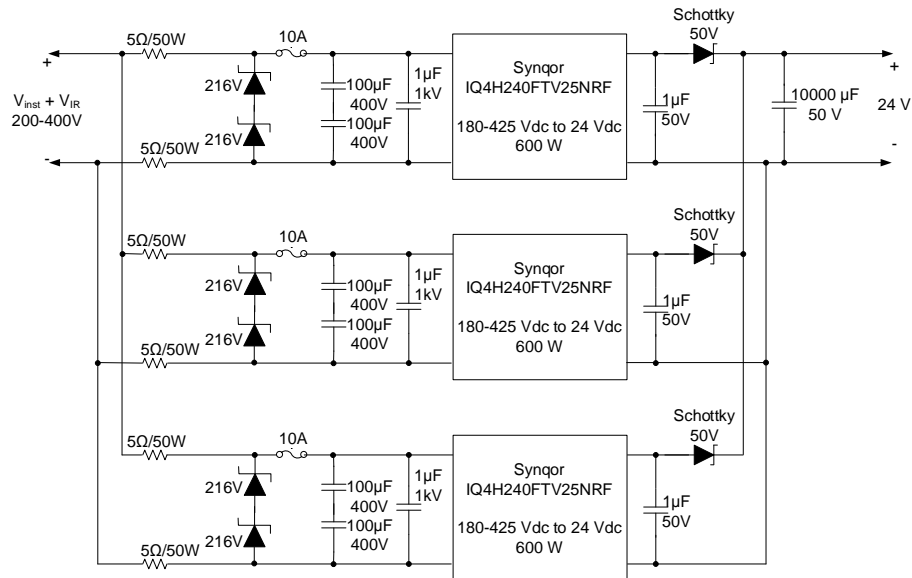

Figure 11 24 V dc ancillary power supply design on board half-scale NWEI device

4.4. Control and data acquisition

A National Instruments CompactRIO controller, model number cRIO-9074, will be used to control the three parallel PowerOne inverters. This controller will operate together with a second NI CompactRIO controller on board the half-scale device; UDP over Ethernet communications will be used between the onboard cRIO and the onshore cRIO in the bunker. The Ethernet connection will be made using the fiber optics in the umbilical, subsea, and terrestrial cables. The onshore cRIO will provide the following functions:

1. Generate a pulsed control input signal for the three inverters per a current command signal sent from the onboard cRIO controller on the device.
2. Monitor the alarm outputs from the three inverters and send a signal to the onboard cRIO to put the device control system into a safe state when there is a loss of ac grid or an inverter fault occurs.
3. Monitor and record ground fault current, and when current exceeds a pre-set threshold send a fault signal to the onboard cRIO controller to put the system into a safe state.
4. Record dc current and voltage data from voltage and current transducers.
5. Provide a remote disable signal for the two 110 V ancillary power supplies so that these power supplies can be turned off remotely when necessary during the test.
6. Receive commands from and send data to the host PC, which is the user interface for the system.

The onshore cRIO-9074 controller will be powered from a UPS in the bunker through a 24 V power supply, so it will keep operating during ac grid power losses up to about 10 minutes in length. A

“heartbeat” signal will be sent back and forth between the onboard cRIO controller on board the NWEI half-scale device and the onshore cRIO controller in the bunker during normal operation; if the heartbeat signal is lost indicating loss of communications, both controllers go into a safe state. In the safe state, the inverters are turned off and the generator output contactors on board the device are opened.

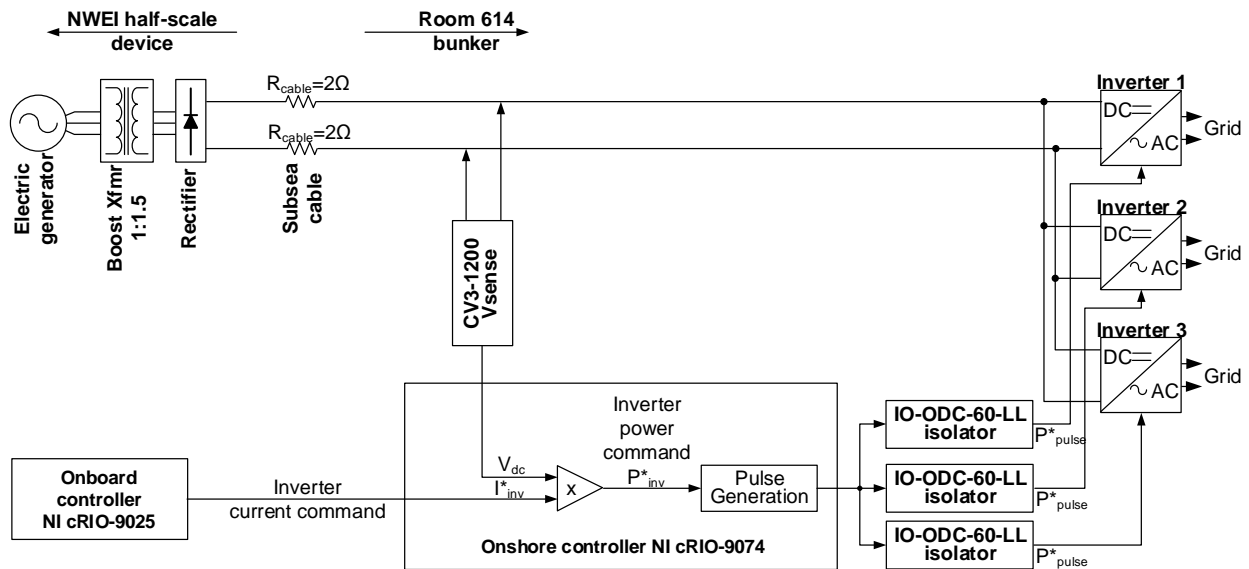

Figure 12 NWEI inverter control method using onshore NI cRIO-9074 controller

Data acquisition and control on board the NWEI device will be provided by a second National Instruments CompactRIO controller, model cRIO-9025. One of the many functions provided by this controller will be to measure three phase ac output power from the device in order to assess device performance. Three ac current sensors and three ac voltage sensors will be used to measure three phase ac voltages at a sampling frequency of 50 Hz; power will be calculated from this sensor data in the controller. These high sampling rates are necessary to measure power with the variable, 0-600 Hz frequencies that may exist at the output of the generator on board the device.

4.5. HECO grid interconnection application

A grid interconnect agreement between NWEI and the Hawaiian Electric Company (HECO) was required to grid connect the NWEI device at Battery French. To obtain this agreement, NWEI submitted the grid interconnect application included in Appendix E. This application includes a drawing of the NWEI grid interconnection design, data sheets for the generator, inverter, and isolation transformers that are described in Section 4.1, information describing a disconnect switch that will be installed outside Battery French, and a NAVFAC electrical one-line diagram from the HECO interface to Battery French.

The most important technical aspect of the interconnect application was the selection of the UL 1741 certified inverter described in Section 4.1 for the NWEI grid connection. Without a UL 1741 certified inverter, HECO indicated that it would be very difficult or impossible to get the interconnect agreement approved.

The NWEI application was approved by HECO approximately 4 months after it was submitted. During the first month, HECO performed a “completeness review” of the application. After this review, HECO asked NWEI for some further information regarding the specification for the generator on board the device. After NWEI submitted this information, HECO proceeded with a technical review of the application. The technical review took approximately 3 weeks, however, the application was held up further because there were issues with potential “saturation” of the distribution circuit due to other renewable generation applications (mostly solar) that were submitted at about the same time as NWEI’s application. Saturation means that renewable power generation penetration limits are exceeded for that circuit, which could cause power system instability within the MCBH. These issues were ultimately resolved and the NWEI interconnect agreement was approved about two months later.

5. NWEI UMBILICAL CABLE, SUBSEA JUNCTION BOX, AND BEND RESTRICTORS

The umbilical cable system for the NWEI device is shown in Figure 13, with the lengths of each segment listed in Table 5. The major components of this system are described below:

- Dry Box – A junction box on the NWEI device that is above water line and serves as the connection point between the NWEI Device and the Umbilical Cable.
- Umbilical Cable – the cable that connects the NWEI Device to the Subsea cable (see Section 3).
- Device Bend Restrictor – located on NWEI Device and is the point at which the Umbilical Cable leaves the NWEI Device. The strength termination of the umbilical to the device is at this point.
- T-Plate – Located on seabed and is the point at which the Umbilical Cable is attached to the seabed. Includes a strength terminator and bend restrictor.
- Subsea J-box – an underwater, oil filled junction box that is the connection point between the umbilical cable and the subsea cable. The Subsea J-box replaces the T-Pod that was used for the previous 30m WETS project.
- Subsea Cable – the existing subsea cable that runs to shore (see Section 3).
- NREL AWAC – an Acoustic Wave and Current Profiler provided by NREL, separately supported on the seafloor. A power and communications cable runs between the Subsea J-box and the AWAC.

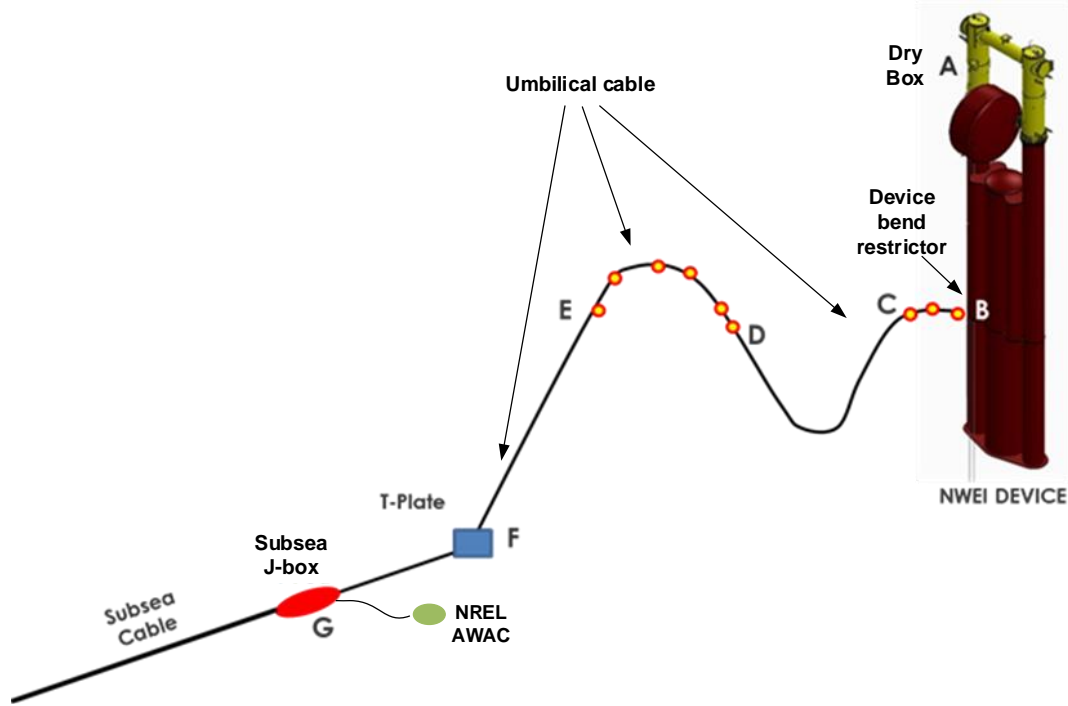

Figure 13 Umbilical cable system for half-scale NWEI device

Table 5 Lengths of umbilical segments

Point/Segment	Description	Segment length, meters	Distance from Drybox	
			Start point	End point
A	Dry Box	1.0	0.0	1.0
A-B	Cable attached to NWEI device	12.0	1.0	13.0
B	Device strength termination point	0.0	13.0	13.0
B-C	Cable with added flotation	3.5	13.0	16.5
C-D	Cable without flotation	16.0	16.5	32.5
D-E	Cable with added flotation	12.0	32.5	44.5
E-F	Cable without flotation	20.0	44.5	64.5
F	T-Plate	0.0	64.5	64.5
F-G	Cable on sea floor between T-plate and J-box	30.5	64.5	95.0
G	J-box including extra cable for contingencies	15.0	95.0	110.0
Total cable length (meters)		110.0		

The NWEI umbilical cable design is based on analysis included in a Sound and Sea Technology Inc. mooring assessment that was performed for NWEI. This mooring assessment is included in Appendix F. Simulations were performed for high ocean currents and also 100 year design waves with the NWEI mooring system and the umbilical configuration shown in Figure 13, where flotation collars are used between points B and C as well as E and D to give a “Lazy-S” shape in the umbilical. The results show that the maximum tension in the umbilical, where it terminates to the device at point B, is always less than 5 kN.

NWEI is procuring components of the system shown in Figure 13 through Ocean Innovations of La Jolla, CA, with Ocean Innovations providing assistance with detailed design. As of spring 2014 all major components with long lead times had been procured including the subsea cable and subsea J-box, however, some of the detailed design involving off-the-shelf items, or items to be fabricated on site in Hawaii, was not complete. Summaries of each of the system components is described in the following subsections.

5.1. Umbilical Cable

A custom umbilical cable has been fabricated by Falmat Custom Cable Technologies for NWEI. A drawing of this cable is included in Appendix G. The specifications for this cable are listed in Table 6. This cable has an outer Kevlar strength member that provides 5 kN operating strength. It includes three 6 AWG power conductors, three pairs of 22 AWG conductors, and six optical fibers. Two of the 22 AWG pairs will be used to 1) provide 24 V power for the NWEI AWAC from the NWEI device, and 2) provide a signal connection between an oil level sensor for the subsea J-box compensator (see Section 5.4) and the data system on board the NWEI device. The third 22 AWG pair will be a spare. Only one of the six optical fibers in the umbilical cable will be used for communications between the NWEI device and shore; the other optical fibers will be spares. The weight of the Falmat cable in air is 1 kg/m.

Table 6 NWEI Umbilical cable specifications

Total length including spare cable	125 m
Maximum working load	5 kN
Power conductors	3
Power conductor size	6 AWG
Nominal current	20 A
Maximum current	60 A
Max voltage	600 V
Optical fibers	6 x 10 μ single mode
Signal conductors*	3 pairs, 22 AWG
AWAC power voltage	24 Vdc

* 22 AWG pairs used for 1) 24 Vdc power to AWAC, and 2) oil level sensor for J-box compensator

The foam flotation needed for the Lazy-S shape of the umbilical will be added at selected points, as described in the Appendix F mooring assessment and shown in Figure 13. The specific collars that will be used have not been selected.

5.2. Subsea J-box

The oil filled, subsea J-box that will be used to connect the umbilical cable to the subsea cable is shown in Figure 14. This J-box has been custom designed and fabricated for NWEI by DOER Marine of Alameda, CA. See Appendix H for a detailed drawing of this J-box. This J-box replaces the transformer pod, or T-Pod, that was used for the previous deployment at the WETS 30m site and is described in the site report (Appendix A). Although the T-Pod houses a transformer that will not be used during the NWEI deployment, it was still possible for NWEI to re-use the T-Pod as a junction box without using the transformer inside. Since the T-Pod is air-filled, however, penetrators or subsea connectors are required for the umbilical entry into the T-Pod, and after investigation NWEI determined that purchasing these penetrators or connectors and doing necessary refurbishments to the T-Pod would be more expensive than having a custom oil filled J-box built. A standard, inexpensive gland can be used to seal the umbilical cable where it enters the J-box because it is oil filled, eliminating the need for penetrators or subsea connectors. The J-box is oil filled and is plumbed with hose to a one liter oil compensator that will be mounted outside. This compensator is not shown in Figure 14; see Appendix H for a data sheet. The compensator will provide 10-15 psi of hydraulic pressure inside the box above outside water pressure. This will assure that oil and not seawater fills gaps in the interstitial space of the umbilical if the outer jacket is punctured, and seawater will not enter the J-box. An oil level sensor in the compensator will be wired via the umbilical cable to the data system on board the NWEI device in order to detect oil leaks before the compensator is empty.

The subsea J-box was designed with the minimum volume necessary to fit the following items:

- The existing penetrators that terminate the WETS 30m subsea cable from the previous 30m WETS project. The end of the subsea cable is presently split into a “Y” to two custom penetrators, one for the three power conductors and the others for fiber optics. These penetrators remain at the end of the subsea cable with protective caps over them.
- A terminal block where connections will be made between the three power conductors in the umbilical and subsea cables.
- Six ST-ST bulkhead fiber connectors where the optical fibers in the subsea and umbilical cables will be terminated.
- A small terminal block (not shown in Figure 14) where umbilical 22 AWG wires will be connected to the AWAC and the oil compensator sensor.
- A serial to fiber converter that will allow communications between the NREL AWAC and shore over fiber optics in the subsea cable.

The subsea J-box will be filled with Royal Purple biodegradable marine hydraulic oil. It will be secured to an existing T-frame on the ocean floor at the 30m site. The AWAC will be separately mounted on the seafloor nearby; a single cable from the AWAC will connect to the J-box through a Subconn subsea bulkhead connector so that the AWAC can be connected and disconnected after deployment as necessary.

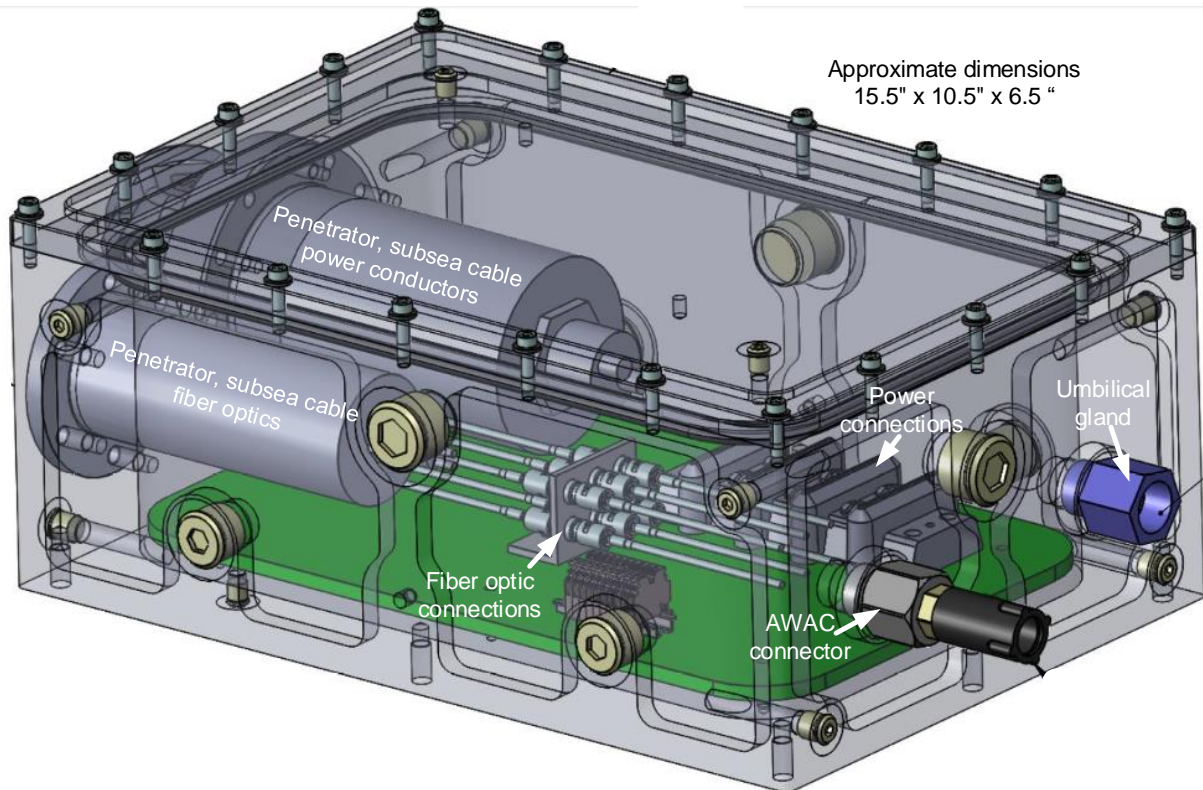

Figure 14 Subsea J-box

5.3. Termination of Umbilical to NWEI Device

The general method that will be used to terminate the umbilical cable on board the NWEI device is shown in Figure 15. The cable will run through a PMI DEF-8 bend restrictor located below the waterline on the hull near the mooring attachment points. This is the same bend restrictor that was used for the 2012 Oregon deployment; see the photograph in Figure 16. A description of the PMI DEF-8 bend restrictor is included in Appendix I. NWEI intends to refurbish and reuse the bend restrictor mounting bracket on board the device that is shown in Figure 16. The strength termination for the umbilical cable will be provided at the bend restrictor using a helical wire, PMI Stopper-Grip that will surround the cable and fit inside the bend restrictor; an eye at the end of the Stopper-Grip will attach to a bracket that will be welded to the hull of the device. See the end of Appendix I for a description of the PMI Stopper-Grip. The cable will then be routed inside of conduit that will be welded to the hull until it reaches the dry box, on the PowerPod above waterline. The cable will enter the dry box through a gland, and electrical terminations will be made inside the dry box.

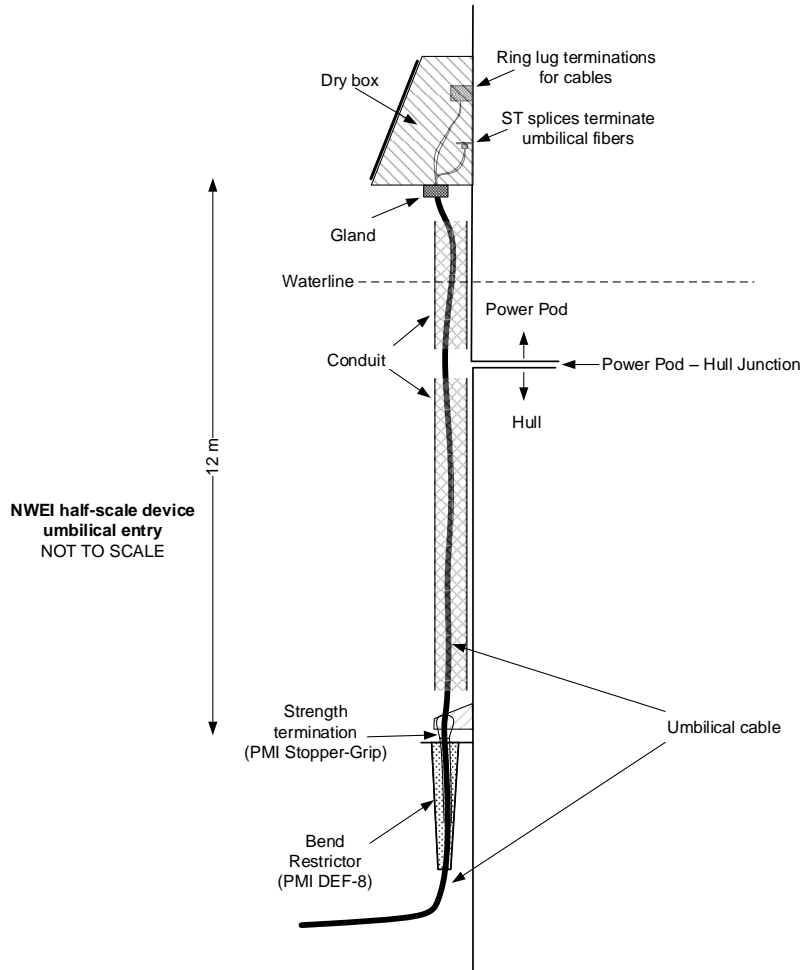

Figure 15 Termination of umbilical cable on board NWEI device



Figure 16 PMI DEF-8 bend restrictor installation on hull of NWEI device for 2012 Oregon deployment

5.4. T-Plate

The umbilical cable will be attached to the sea floor at a new T-Plate that NAVFAC will have fabricated in Hawaii prior to deployment. A previous T-Plate used for the earlier wave energy program at the 30m WETS site has been removed from the site and scrapped. NWEI intends to use the same PMI DEF-8 bend restrictor and PMI Stopper-Grip strength termination that are described in Appendix I at the T-Plate that are used at the NWEI device. The detailed design for the new T-Plate is not yet complete.

APPENDICES

Appendix A – WETS 30m Site Report

Appendix B –Electrical Schematics for NWEI Equipment in WETS Bunker

Appendix C – Inverter Isolation Transformer Drawing

Appendix D – Analysis of Cable Inductance and Capacitance Effects on System

Appendix E – HECO Grid Interconnection Application

Appendix F – Mooring Assessment for NWEI 30m WETS Deployment

Appendix G – Umbilical Cable Drawing

Appendix H – Subsea J-Box Drawing and Oil Compensator Information

Appendix I – Umbilical Cable Bend Restrictor and Strength Termination Information

GLOSSARY OF TERMS & ACRONYMS

ac	Alternating Current
AWAC	Acoustic Wave and Current Profiler, manufactured by Nortek
AWG	American Wire Gauge
DAS	Data Acquisition System
dc	Direct Current
HECO	Hawaiian Electric Company
HNMREC	Hawaii National Marine Renewable Energy Center
J-box	Junction box
kW	Kilowatt, unit of power equivalent to 1000 Watts
kVA	Kilo Volt-Amperes, a unit of reactive power
MCBH	Marine Corps Base Hawai'i
NAVFAC	Naval Facilities Engineering Command
NREL	National Renewable Energy Laboratory, a U.S. DOE Laboratory
NWEI	Northwest Energy Innovations, a wholly-owned subsidiary of Pacific Energy Ventures formed for the specific purpose of advancing the WET-NZ design in the U.S.
PM	Permanent Magnet, usually in reference to a permanent magnet ac generator.
PTO	Power Take Off, the system for converting mechanical energy to electrical energy
T-plate	The structure on the seafloor where the strength terminator and bend restrictor for the umbilical cable will be installed.
T-pod	Transformer Pod, a subsea chamber housing a step up transformer, where the connection between the umbilical and subsea cables was made at the previous wave energy program at the 30m WETS.
UL	Underwriters Laboratory
UPS	Uninterruptible Power Supply
WEC	wave energy converter
WET-NZ	Wave Energy Technology - New Zealand, the wave energy converter technology under development
WETS	Wave Energy Test Site