

PAPER • OPEN ACCESS

Simulation Modeling The Performance of Ocean Thermal Energy Conversion Power Cycle

To cite this article: N Samsuri *et al* 2021 *IOP Conf. Ser.: Mater. Sci. Eng.* **1062** 012034

View the [article online](#) for updates and enhancements.

Simulation Modeling The Performance of Ocean Thermal Energy Conversion Power Cycle

N Samsuri^{1*}, N Sazali², A S Jamaludin³, and M N M Razali³

¹ Ocean Thermal Energy Centre (OTEC), Ground Floor, Block Q, Universiti Teknologi Malaysia Kuala Lumpur, Jalan Sultan Yahya Petra, 54100 Kuala Lumpur, Malaysia.

² Department of Electrical Engineering, College of Engineering, Universiti Malaysia Pahang, 26300 Gambang, Kuantan, Pahang, Malaysia.

³ Faculty of Manufacturing and Mechatronics Engineering Technology, Universiti Malaysia Pahang, 26600 Pekan, Pahang, Malaysia

*Corresponding e-mail: norazreen1989@gmail.com

Abstract. Ocean Thermal Energy Conversion (OTEC) is a foundation for an appealing renewable energy technology with regards to its vast and inexhaustible resources of energy, renewability, stability, and sustainable output. The principle of an OTEC power plant is to exploit the energy stored in between the upper layer of warm surface seawater (heat source), and the cold layer of deep seawater (heat sink). The plant operates based on a Rankine cycle to produce electricity between the source and the sink at the minimum temperature difference of approximately 20 K. The main objective of this study is to evaluate the performance of the proposed OTEC closed Rankine cycle using ammonia as the working fluid, to be paralleled with basic OTEC Rankine cycle. Preliminary simulation was performed at the initial stage of the study to validate the simulation model by referring to previous OTEC studies. The same developed model was deployed to test the efficiency of the proposed modified OTEC Rankine cycle, resulting in an enhancement in terms of thermal cycle performance from 3.43% to 7.98%. This study has revealed that the proposed OTEC closed Rankine cycle which introduced an interstage superheating as well as an improved condenser cooling system, augmented the system competence of an OTEC power cycle.

Keywords: ocean, thermal energy, renewable, modelling, Rankine cycle

1. Introduction

Ocean Thermal Energy Conversion (OTEC) has tremendous prospective in deep ocean water area, in which there is an enough high temperature difference between the surface water and a precise depth that is necessary to effectively run an OTEC power plant. In 1881, Arsonval's initial thought specified that the optimum temperature difference needed for the installation of an OTEC plant is larger than 20K [1]. The system will work between the surface seawater at 30°C (known as heat source), and seawater at 1000 m depth with temperature of 4°C (known as heat sink) [2-4]. OTEC power plant technology is developed on a basis of open (OC-OTEC) and closed Rankine cycles (CC-OTEC). Aforementioned research reported that the process must be founded upon the Uehara cycle for optimal power plant output, applying ammonia-water mixture as the working fluid with smaller than 20 K of temperature difference, and at 5-6% thermal efficiency [5].



Malaysia has never previously been on any world map showing areas with the potential for OTEC power generation. Nevertheless, owing to the works done by Sapura-Crest Group's Subsidiary Teknik Lengkap GeoSciences Sdn Bhd, a marine survey was carried out at the South China Sea in 2008 [6]. It proved that the temperature of approximately 4°C is attained at the ground under the North-Borneo Trough, which is also acknowledged as the Sabah Trough (illustrated in Figure 1), as different to the temperature of nearly 29°C on the surface. The discovery described above offered Malaysia a chance to effectively run an OTEC plant. Rendering to data estimates, the Sabah Trough is 60 km in width, 100 km in length and has an average depth of 1000 m. Necessary research is required to reach the maximum output of OTEC while at the same time minimalizing the cost of capital.

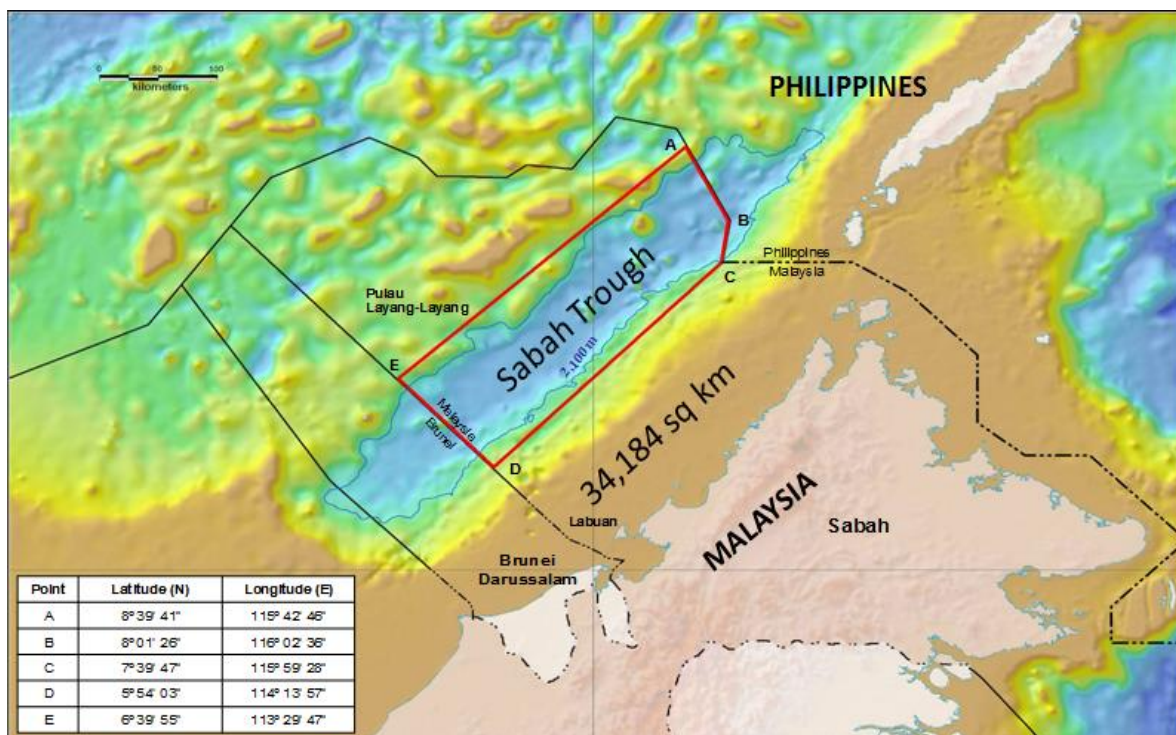

Figure 1. The Sabah Trough's position and region discovered by Sapura-Crest Group's Subsidiary Teknik Lengkap GeoSciences Sdn. Bhd. [6].

The first OTEC system was suggested by D'Arsonval (1881) which associated with the closed Rankine cycle, using a turbine with low-pressure attributed by its low operating temperature, thus formed 3% of thermal efficiency [1]. The introduced closed Rankine cycle consisted of an evaporator, a turbine, a condenser, and three designated pumps for working fluid, surface seawater (SSW) and deep seawater (DSW) as shown in Figure 2. In 1985, Dr. Kalina has come out with the Kalina cycle which was a modification from closed Rankine cycle with the addition of a separator, an evaporator, an absorber, and a decreasing valve. The cycle has developed the OTEC system performance by 4% [5]. Far ahead at Saga University in Japan, the Uehara cycle was introduced, in which the outcome showed 3% higher efficiency compared to a basic closed-cycle OTEC system [7,8]. Uehara cycle was conceived based on the Kalina cycle with the overview of a turbine, a heater, a tank, a pump for working fluid and a diffuser. the Uehara cycle trend showed a slight improvement in plant efficiency with some risk in terms of plant difficulty and production cost.

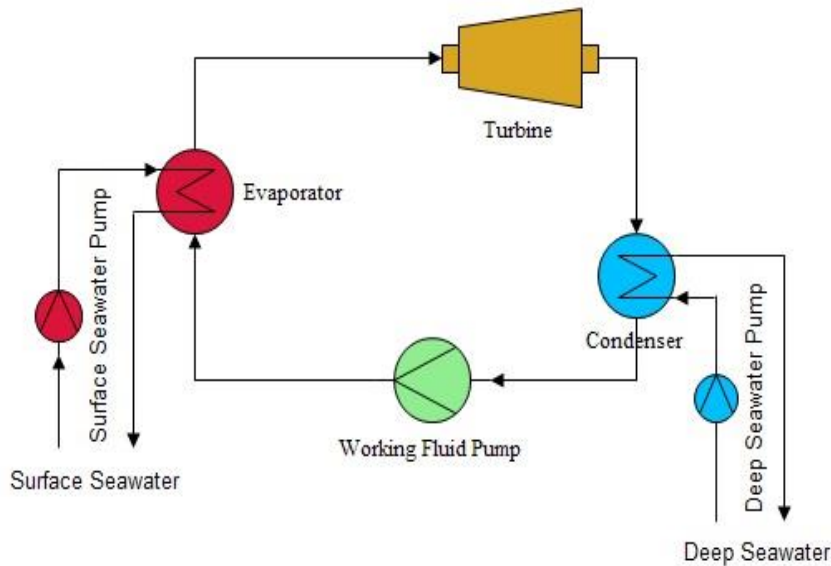

Figure 2. Schematic diagram of OTEC closed Rankine cycle by Arsonval (1881).

Given that there is sufficient energy supply from the SSW, this current study proposes preheating using an external source of heat, as illustrated in Figure 3. To alleviate the performance failure, a multi-stage turbine that uses an exterior source of heat to conduct interstage superheating is suggested. In spite of that, the multi-stage expansion would raise the condenser's cooling demand, and thus increase the flow rate or power needed to pump the DSW. From now, the suggested OTEC closed Rankine cycle (illustrated in Figure 3) utilizes a closed loop condenser to reduce the probable adverse effect of DSW upwelling on the underwater environment. Furthermore, the commercial plant used titanium as pipe material to surmount biofouling. Undeniably, this customization will also decrease the biofouling effect on the inner side of the heat exchanger tube, enabling the use of low-price materials for condenser fabrication. Consequently, in this study, the issue of evaporator and condenser as the most lavish components will be addressed by introducing the use of a closed loop of evaporator and condenser.

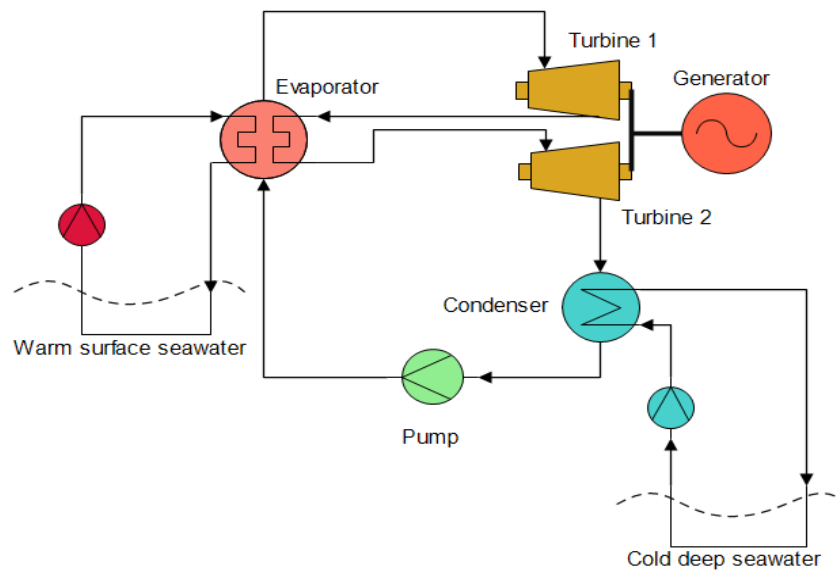

Figure 3. Schematic diagram of the proposed OTEC closed Rankine cycle with modified evaporator heating and condenser cooling systems.

2. Methodology

2.1. Introduction

Laboratory Virtual Instrument Engineering Workbench (LabVIEW) is a platform for framework design created by National Instruments employed as a language for visual programming. Its use in frequent fields of engineering (e.g. aeronautical, mechanical, electrical, etc.) has led to the advancement of many of the world's major and most complex applications to achieve future demands. LabVIEW compromises the users with flexibility through intuitive graphical programming which helps to reduce the time needed for test development. A simulation of LabVIEW is conducted through five stages as indicated in Figure 4. The thermodynamic model has been made in LabVIEW and linked to the working fluid data base in National Institute of Standards and Technologies (NIST) RefProp 9.

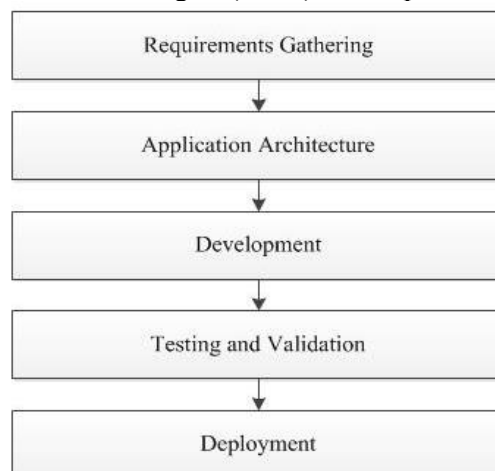

Figure 4. Steps involved in LabVIEW simulation.

2.2. Analytical Techniques of Thermodynamics

The simulation was based upon the thermodynamic analysis of the OTEC Rankine cycle performance. The Rankine cycle contains of four major components, which are condenser, coolant pump, turbine, and evaporator. Numerous expectations were comprised to facilitate the simulation analysis and assessment [13,14] defined as follows:

- Each component is in steady state;
- Any heat loss and pressure drop are disregarded;
- The system is entirely insulated; and
- All pumps and turbines are given isentropic efficiency.

For the steady state energy balance equation, the total energy entering a system is equal to the total energy exiting the system, as stated in equation (1)

$$E_{in} = E_{out} \quad (1)$$

or it can be elaborated as in equation (2)

$$W_{in} + Q_{in} + \sum \dot{m}_{in} = W_{out} + Q_{out} + \sum \dot{m}_{out} \quad (2)$$

where \dot{Q} represents heat transfer rate; \dot{m}_{in} and \dot{m}_{out} is inlet and outlet mass flow rate; whereas W_{in} and W_{out} is work inlet and outlet, respectively. By assuming the system is completely insulated and any heat losses are neglected; which $Q_{in} = Q_{out} = W_{out} = 0$, therefore the energy balance in the pump is expressed as in equation (3):

$$W_{in} + \sum \dot{m}_{in} = \sum \dot{m}_{out} \quad (3)$$

From equation (3), the work supplied is given as in equation (4):

$$W_{in} = \sum \dot{m}_{out} - \sum \dot{m}_{in} \quad (4)$$

Rate of heat supplied to the cycle (evaporator), \dot{Q}_e is expressed as in equation (5) :

$$\dot{Q}_e = \dot{m}_{wf} \Delta h_e \quad (5)$$

Rate of heat rejected from the cycle (condenser), \dot{Q}_c is indicated as in equation (6):

$$\dot{Q}_c = \dot{m}_{wf} \Delta h_c \quad (6)$$

Rate of heat absorbed from the warm seawater, $\dot{Q}_{e,ws}$ is expressed as in equation (7):

$$\dot{Q}_{e,ws} = \dot{m}_{ws} c_p \Delta T_{ws} \quad (7)$$

Rate of heat rejected into the cold seawater, $\dot{Q}_{c,cw}$ is indicated as in equation (8) :

$$\dot{Q}_{c,cw} = \dot{m}_{cs} c_p \Delta T_{cs} \quad (8)$$

where \dot{m}_{ws} and \dot{m}_{cs} are the mass flow rate of warm and cold seawater, respectively. c_p is the seawater specific heat capacity at constant pressure. The working fluid pump, $W_{P_{wf}}$ and the turbine work, W_T is written as in equation (9) and equation (10)

$$W_{P_{wf}} = \dot{m}_{wf} v(P_2 - P_1) \quad (9)$$

$$W_T = \dot{m}_{wf} \Delta h \quad (10)$$

where Δh represents the enthalpy difference in the turbine system.

Referring to Uehara and Ikegami (1990) [14], the working fluid pumping power, is given as in equation (11). The pumping power of warm seawater, is indicated in equation (12); whereas the pumping power of cold seawater, is expressed in equation (13)

$$P_{P_{wf}} = \frac{\dot{m}_{wf} \Delta H_{wf} g}{\eta_{wf,p}} \quad (11)$$

$$P_{ws} = \frac{\dot{m}_{ws} \Delta H_{ws} g}{\eta_{ws,p}} \quad (12)$$

$$P_{cs} = \frac{\dot{m}_{cs} \Delta H_{cs} g}{\eta_{cs,p}} \quad (13)$$

where ΔH refers to the difference in pressure. The net power output, P_n is indicated as in equation (14) below:

$$P_n = P_G - P_{ws} - P_{cs} - P_{P_{wf}} \quad (14)$$

2.3. Preliminary Simulation

An ideal working fluid should have the related thermophysical properties corresponding with its application, as well as the capability to withstand its chemical stability within the definite range of temperature. Working fluid selection plays a foremost part on the system in terms of its performance, operating conditions, effects on the environment and economic feasibility. In this section, the parameters for recognizing a suitable working fluid for the cycle system are defined. Sami and co-workers (2012) [15] has itemized the main factors disturbing the properties of thermodynamics and thermophysics of the system, among which are thermal conductivity, chemical stability, specific heat, boiling temperature, latent heat, toxicity, in addition to flash point, as defined in Figure 5.

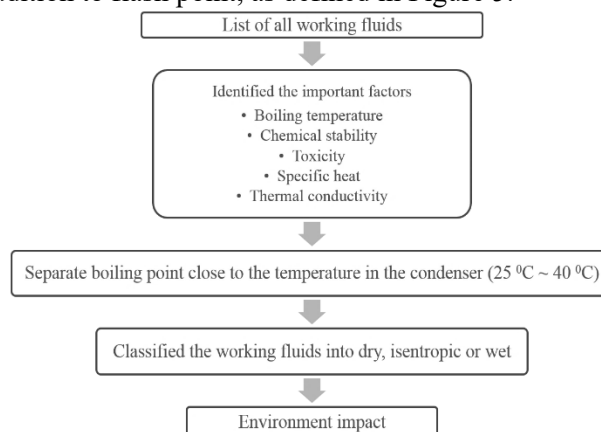

Figure 5. Steps in selecting the working fluids [15].

The OTEC closed Rankine cycle in this study exploited the boiling point of the working fluid near the evaporator operating temperature, which is about 25°C to 40°C [16]. In addition, the fluids were classified as dry, isentropic or wet relative to the saturation curve (dT/ds). A dry or isentropic fluid is proper to be used in OTEC closed Rankine cycle [17]. The purpose of separating the type of fluids is to make sure that the fluids are completely superheated after isentropic expansion, intended to evade the presence of liquid drops on the blades of the turbine.

2.4. Types of Working Fluids

There are two kinds of working fluid, specifically pure fluid (pure compound) and pseudo-pure fluid (a mix of several pure compounds of fluid). Ammonia, propane, R22, R134a, and R143a, are marked as pure fluid, and are not combined with any other compounds. Temporarily, ammonia-water mixture, R404a, R410a, R470c, and R507a are pseudo-pure fluids. Figure 6(a) show that the highest enthalpy change can be exposed in ammonia-water mixture, followed by ammonia, propane and R32. According to Figure 6(b), in contrast with other working fluids, ammonia-water mixture has the highest quantity of heat applied. This situation is instigated by its larger latent heat value, also can be defined as the amount of heat that a liquid absorbs to stay at a constant pressure or temperature throughout the process of vaporization.

2.5 Preliminary Simulation

A preliminary design model for simulation of a 1 MWe OTEC closed Rankine cycle was accompanied by means of ammonia as the working fluid. This preliminary simulation is to validate the model developed by [11]. Apart from that, the preliminary design model allows the approximation for 5MWe and 10MWe OTEC closed Rankine cycle.

Table 1. Parameters for three OTEC cycles to be investigated

Parameter	Symbol	Unit	Value
Evaporating temperature	T_E	°C	28
Condensing temperature	T_C	°C	8
Warm seawater inlet temperature	T_{wsw}	°C	30
Cold deep seawater inlet temperature	T_{csw}	°C	5
Working fluid pump efficiency	η_{wf}	%	0.75
Turbine efficiency	η_T	%	0.82
Generator efficiency	η_G	%	0.95
Warm seawater pump efficiency	$\eta_{pump,wsw}$	%	0.80
Cold deep seawater pump efficiency	$\eta_{pump,csw}$	%	0.80

The OTEC closed Rankine cycle simulation based on reference [10] was showed according to the fixed condition parameters as tabulated in Table 1, in which the ammonia is in steady state. The graph that signifies the simulated model is shown in Figure 6(b). When relating the reference case with the preliminary analysis, it was found that ammonia generated the uppermost total work output. Such results are strengthened by the fact that ammonia influenced the maximum as well as the most appropriate value of latent heat for the OTEC cycle system.

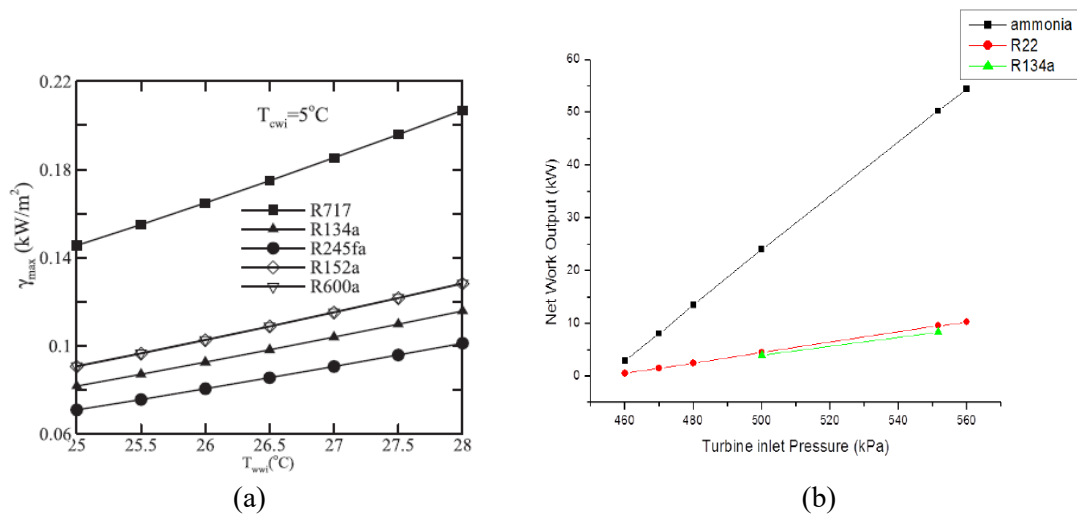

Figure 6. (a)The network output of closed Rankine cycle using several working fluids[11]; (b)Simulation model using LabVIEW and RefProp.

Table 2. Analysis of OTEC Closed Rankine cycle using ammonia as working fluid

	Unit	1MWe	5MWe	10MWe
Q_{in}	kW	19724.40	81375.50	162751.00
Q_{out}	kW	18685.00	76166.90	152334.00
$W_{p(wf)}$	kW	13.22	54.53	109.06
$W_{p(wsw)}$	kW	96.74	399.12	798.24
$W_{p(cws)}$	kW	118.76	484.11	968.21
\dot{m}_{wf}	kg/s	15.82	65.25	130.50
\dot{m}_{Wsw}	kg/s	1793.01	7397.29	14794.60
\dot{m}_{Csw}	kg/s	1587.67	6471.91	12943.80
W_T	kW	905.00	4525.00	9050.00
W_{net}	kW	676.28	3587.24	7174.48

As can be seen from Table 2, the net power output increased expressively after the system was scaled up [12]. The primary study acts as an initiation to the visualization procedure used in the subsequent assessment in Section 3. On the other hand, the preliminary simulation is exposed to elucidate the adequacy of the parameters used in this study.

3. Results and Discussion

The basic OTEC closed Rankine cycle has been optimized to generate more work output by assuming two-stage steam turbines that implement interstage superheating along with revised condenser cold deep seawater cooling system regardless of the cycle's cost effect. The assumptions made regarding the working condition is the critical factor and these considerations arise in order to emphasis the evaluation on the impact of implementing interstage superheating as well as modified condenser cooling system. Both the basic and proposed closed Rankine cycle used the alike considerations and methodology.

Figure 7 shows the T-s diagram of the suggested OTEC closed Rankine cycle. The process from point 1 to 2 corresponded to the constant pressure heat addition in the evaporator. Points 2 to 3 signified the complete steam expansion that was disturbed in the high-pressure turbine, and steam was emitted after partial expansion. Using warm seawater, the reheated steam was complete additionally at point 4 to a turbine with low-pressure for full expansion, and the pressure of steam reaches the condenser pressure value at point 5. The process from point 5 to 6 represented the constant pressure of heat rejection

process in the condenser; whereas points 6 to 1 corresponded to the working fluid pump compressing the working fluid to the operating pressure of the evaporator. Additionally, the T-s diagram in Figure 7 presented a slight increase in the region that linked with the implementation of steam reheating. Consequently, the reheating process improved the work output due to the expansion work of the turbine at low-pressure. The primary intention of reheating is to shield the blade of the turbine by removing the moisture subsequent from the steam.

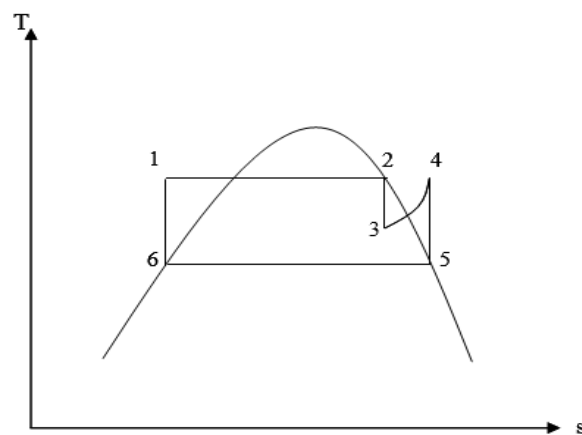

Figure 7. T-s diagram of the proposed OTEC closed Rankine cycle.

Additionally, the use of two turbines has given the advantage of improving the cycle performance [13]. It frequently occurs because when a working fluid at a higher temperature is organized, a greater proportion of heat flows through the cycle. Furthermore, the exhaust steam energy and the heat attained from the warm seawater permitted a significant amount of work to be generated. Two turbines generated much greater work output compared to a single turbine. Nevertheless, the disadvantage of the use of two turbines was the high cost in terms of manufacturing and maintenance.

The preliminary simulation performance of the suggested cycle not only showed a minimal improvement in terms of net power output, but also the cycle efficiency was found to be twice as more associated to a basic OTEC closed Rankine cycle. Clearly, Table 3 revealed that the implementation of interstage superheating contributed to an enhancement of 4.5% to the basic OTEC closed Rankine cycle. In reality, utilizing two or more phases in the Rankine cycle might include significantly smaller turbines that might lead to a performance decline [14,15]. Nonetheless, this study concluded that a higher work output and performance can be attained with the modified OTEC closed Rankine cycle, however it essential supplementary costs due to the use of two turbine stages.

Furthermore, a modified condenser cooling system has also been recognized in this work. The condenser used an open loop for the previous works, but a modification has been made in this recent research where a closed loop was used for the condenser cooling system using ethylene glycol as the chiller. Ethylene glycol was identified as the typical working fluid in the air conditioning sector. Thus in this case, the synergy between air conditioning technology and OTEC technology might be presumed. Ethylene glycol was extensively used for standard cooling applications as an antifreeze fluid; henceforth it was designated as the heat transfer medium for cold seawater in this proposed cycle. Taking into account a 20% of safety factor, the system cooling capacity using ethylene glycol was 9569.88 kW, while the system cooling capacity applying deep seawater was 10471.75 kW. In brief, the use of ethylene glycol in the suggested closed-loop condenser cooling system helped to minimize the cooling capacity required for the condenser. Besides, applying the recommended closed-loop condenser cooling system would mitigate the biofouling effect in the tube of condenser.

Table 3. Calculated results of the proposed OTEC closed Rankine cycle and the basic OTEC closed Rankine cycle using ammonia as working fluid.

	Unit	Evaluation of 1MW OTEC power plant	
		Basic OTEC Closed	Proposed OTEC Closed
		Rankine Cycle	Rankine Cycle
P_E	kPa	1099.30	1099.30
P_C	kPa	573.70	573.70
Q_{in}	kW	19724.40	9237.98
Q_{out}	kW	18685.00	8189.88
$W_{p(wf)}$	kW	13.22	6.17
$W_{p(wsw)}$	kW	96.74	43.80
$W_{p(cws)}$	kW	118.76	52.05
\dot{m}_{wf}	kg/s	15.82	7.38
$\dot{m}_{W_{SW}}$	kg/s	1793.01	811.77
$\dot{m}_{C_{SW}}$	kg/s	1587.67	695.89
W_T	kW	905.00	756.58
W_{net}	kW	676.28	737.22
η	%	3.43	7.98

4. Conclusion

In summary, a model which incorporated LabVIEW and Refprop softwares was efficaciously established and deployed for a preliminary assessment of the OTEC cycle efficiency. The initial analysis of a test run at a net power output of 1 MW showed a close agreement with that of existing data. The study was further extended to study the competency of a proposed modified OTEC Rankine cycle, in which the evaluation was led using the similarly developed model. The outcome presented an enhancement in thermal cycle efficiency from 3.43% to 7.98%. Therefore, this study has proved that there are enhancements on the performance of changed closed Rankine cycle that introduced interstage superheating as well as modified condenser for cold deep seawater cooling system.

Acknowledgments

The authors express gratitude to the Ocean Thermal Energy Centre (OTEC) lecturers and staffs, Universiti Teknologi Malaysia for their knowledge, laboratory, and equipment supplied. The authors also thanked to Ministry of Higher Education (MOHE) for financially supported this study through The Fundamental Research Grant Scheme for Research Acculturation of Early Career Researchers, FRGS-RACER/1/2019/TK05/UMP//1 - RDU192621.

References

- [1] D'Arsonval J 1881 *Reveu Scientifique* 370-372
- [2] Nihous G C 2005 An Order-of-Magnitude Estimate of Ocean Thermal Energy Conversion Resources *Journal of Energy Resources Technology* **127(4)** 328
- [3] Nihous G C 2007 A Preliminary Assessment of Ocean Thermal Energy Conversion Resources *Journal of Energy Resources Technology* **129(1)** 10
- [4] Vega L A 2002 Ocean Thermal Energy Conversion Primer. *Marine Technology Society Journal* **36(4)** 25-35
- [5] Zhang X, He M and Zhang Y 2012 A Review of Research on the Kalina Cycle. *Renewable and Sustainable Energy Reviews* **16(7)** 5309-5318

- [6] Sapura-Crest Group's Subsidiary TLG GeoSciences Sdn. Bhd. 2008 *Malaysia Marine Survey in the South China Sea (MyMRS)*
- [7] Uehara H, Ikegami Y and Nishida T 1994 Performance Analysis of OTEC Using New Cycle with Absorption and Extraction Process *Proc. of Oceanology Int. '94* 1-11
- [8] Wang C M, Yee, A A, Krock H and Tay Z Y 2011 Research and Developments on Ocean Thermal Energy Conversion *The IES Journal Part A: Civil & Structural Engineering* **4(1)** 41-52
- [9] Wu C and Burke T 1998 Intelligent Computer Aided Optimization on Specific Power of an OTEC Rankine Power Plant *Applied Thermal Engineering* **18(5)** 295-300
- [10] Uehara, H., & Ikegami, Y. 1990. Optimization of a Closed-cycle OTEC System. *Transaction of the ASME Journal of Solar Energy Engineering*. 112-4: 247-256.
- [11] Yeh R H, Su T Z, and Yang M S 2005 Maximum Output of an OTEC Power Plant. *Ocean Engineering* **32(5-6)** 685-700
- [12] Upshaw C R 2012 Thermodynamic and Economic Feasibility Analysis of a 20 MW Ocean Thermal Energy Conversion (OTEC) Power
- [13] Sun F, Zhou W, Ikegami Y, Nakagami K and Su X 2014 Energy-exergy Analysis and Optimization of the Solar-boosted Kalina Cycle System 11 (KCS-11) *Renewable Energy* **66** 268-279
- [14] Yamada, N, Hoshi A and Ikegami Y 2009 Performance Simulation of Solar-boosted Ocean Thermal Energy Conversion Plant *Renewable Energy* **34(7)** 1752-1758
- [15] Kim N J, Ng K C, and Chun W 2009 Using the Condenser Effluent from a Nuclear Power Plant for Ocean Thermal Energy Conversion (OTEC) *International Communications in Heat and Mass Transfer* **36(10)** 1008-1013