



Unlocking the Potential of Marine Energy Using Hydrogen Generation Technologies

Jacob Thorson, Chris Matthews, Michael Lawson, Kevin Hartmann, Muhammad Bashir Anwar, and Paige Jadun

National Renewable Energy Laboratory

**NREL is a national laboratory of the U.S. Department of Energy
Office of Energy Efficiency & Renewable Energy
Operated by the Alliance for Sustainable Energy, LLC**

This report is available at no cost from the National Renewable Energy Laboratory (NREL) at www.nrel.gov/publications.

Contract No. DE-AC36-08GO28308

Technical Report
NREL/TP-5700-82538
June 2022



Unlocking the Potential of Marine Energy Using Hydrogen Generation Technologies

Jacob Thorson, Chris Matthews, Michael Lawson, Kevin Hartmann, Muhammad Bashar Anwar, and Paige Jadun

National Renewable Energy Laboratory

Suggested Citation

Thorson, Jacob, Chris Matthews, Michael Lawson, Kevin Hartmann, Muhammad Bashar Anwar, and Paige Jadun. 2022. *Unlocking the Potential of Marine Energy Using Hydrogen Generation Technologies*. Golden, CO: National Renewable Energy Laboratory. NREL/TP-5700-82538. <https://www.nrel.gov/docs/fy22osti/82538.pdf>.

**NREL is a national laboratory of the U.S. Department of Energy
Office of Energy Efficiency & Renewable Energy
Operated by the Alliance for Sustainable Energy, LLC**

This report is available at no cost from the National Renewable Energy Laboratory (NREL) at www.nrel.gov/publications.

Contract No. DE-AC36-08GO28308

Technical Report
NREL/TP-5700-82538
June 2022

National Renewable Energy Laboratory
15013 Denver West Parkway
Golden, CO 80401
303-275-3000 • www.nrel.gov

NOTICE

This work was authored in part by the National Renewable Energy Laboratory, operated by Alliance for Sustainable Energy, LLC, for the U.S. Department of Energy (DOE) under Contract No. DE-AC36-08GO28308. Funding provided by U.S. Department of Energy Office of Energy Efficiency and Renewable Energy Hydrogen and Fuel Cell Technologies Office. The views expressed herein do not necessarily represent the views of the DOE or the U.S. Government.

This report is available at no cost from the National Renewable Energy Laboratory (NREL) at www.nrel.gov/publications.

U.S. Department of Energy (DOE) reports produced after 1991 and a growing number of pre-1991 documents are available free via www.osti.gov.

Cover Photos by Dennis Schroeder: (clockwise, left to right) NREL 51934, NREL 45897, NREL 42160, NREL 45891, NREL 48097, NREL 46526.

NREL prints on paper that contains recycled content.

Acknowledgments

This project was funded by the U.S. Department of Energy's (DOE's) Hydrogen and Fuel Cell Technologies Office. Thank you to William McShane of DOE's Water Power Technologies Office and Eric Miller of DOE's Hydrogen and Fuel Cell Technologies Office for their support and review of this work.

List of Acronyms

AEM	anion exchange membrane
BOP	balance of plant
CHS	compressed hydrogen storage
DOE	U.S. Department of Energy
DSE	direct seawater electrolysis
NREL	National Renewable Energy Laboratory
OTEC	ocean thermal energy conversion
PEM	proton exchange membrane
PV	photovoltaic
SOEC	solid oxide electrolysis cell
UUV	unmanned underwater vehicle
WEC	wave energy converter

Executive Summary

Marine energy, including ocean waves, ocean currents, ocean thermal gradients, tides, and river currents, is a vast and untapped resource that can be harnessed to help enable the transition to renewable energy. Marine energy is an attractive renewable resource because of its energy density, predictability, and persistence. Further, marine energy has the potential to provide energy for utility-scale applications, remote and distributed applications, and rapidly expanding maritime industries, such as aquaculture and shipping. Marine energy technologies are, however, at a nascent stage of development, and a significant amount of the resource is located far from population centers and transmission infrastructure. Accordingly, to unlock the full potential of marine energy, efficient methods of storing and transporting captured marine energy are needed so that the energy can be used when and where it is needed. A promising solution to these energy storage and transportation challenges is to combine marine energy and hydrogen generation technologies. Herein, we provide a high-level analysis of the unique value proposition and technical challenges of combining marine energy and hydrogen technologies. First, we review marine energy technologies, electrolysis technologies, and hydrogen storage methods. Next, we consider specific applications and opportunities for combining the two technologies. Finally, we identify critical R&D challenges that must be overcome to successfully combine marine energy and hydrogen generation technologies. As part of our fact-finding effort in this area, we held a workshop attended by marine energy and hydrogen technology experts from industry, academia, national labs, and government entities to explore the technical challenges and opportunities for combined marine energy and hydrogen generation systems. Our intent is that this document and the report from the workshop can be used in conjunction to help identify and direct research and development that is needed to realize the potential of marine energy-hydrogen systems.

Table of Contents

1	Introduction	1
2	Marine Energy Resources	2
2.1	Tidal Energy	4
2.1.1	Intensity and Location	4
2.1.2	Predictability and Variability	4
2.1.3	Tidal Energy Converters	5
2.2	Wave Energy	5
2.2.1	Intensity and Location	5
2.2.2	Predictability and Variability	6
2.2.3	Wave Energy Conversion	8
2.3	Ocean Current Energy	10
2.3.1	Intensity and Location	10
2.3.2	Predictability and Variability	10
2.3.3	Ocean Current Energy Conversion	11
2.4	Ocean Thermal Energy	11
2.4.1	Resource Intensity and Location	12
2.5	Salinity Gradients	12
2.6	Energy Resources at the Seafloor	13
2.6.1	Hydrothermal Vents	13
2.6.2	Methane Hydrate Deposits	13
3	Hydrogen Generation and Use	14
3.1	Electrolysis Technologies	15
3.2	Near-Term Marine Energy-H ₂ Integration	15
3.2.1	Liquid Alkaline Electrolysis	17
3.2.2	PEM Electrolysis	17
3.3	Medium- and Long-Term Water Electrolysis Options	18
3.3.1	Solid Oxide Electrolysis	18
3.3.2	High-Pressure PEM Electrolysis	19
3.3.3	AEM Electrolysis	20
3.3.4	Direct Seawater Electrolysis	20
3.4	Balance of Plant	21
3.4.1	Electrical Integration and Operation Considerations	22
3.4.2	Desalination Providing Feed Water for Electrolysis	22
3.4.3	Packaging Considerations for Marine Deployments of Electrolysis	23
3.4.4	Compression	23
3.4.5	Typical Round-Trip Efficiency	24
3.5	Hydrogen Storage	25
3.5.1	Physical-Based Storage	26
3.5.2	Material-Based Storage	29
4	Potential Applications of Marine Energy-H₂ Systems in the Blue Economy	30
4.1	Ocean Observation and Navigation	33
4.2	Marine Transportation	35
4.3	Unmanned Underwater Vehicle Refueling	36
4.4	Offshore Marine Aquaculture and Algae	38
4.5	Coastal/Island Microgrids and Resiliency	40
4.6	Powering Multiple Applications	42
4.7	Discussion	43
5	Previous Investigations of Marine Energy to Hydrogen Applications	44
5.1	Marine Hydrogen Demonstration Projects	44

5.2	Paper Studies, Laboratory-Scale Experiments, and Patents.....	49
6	Unique Aspects of Marine Energy to Hydrogen.....	54
6.1	Geographic Co-Location.....	54
6.1.1	Possible Benefits.....	54
6.1.2	Challenges of Marine Energy and H ₂	54
6.1.3	Related Metrics To Evaluate Systems.....	54
6.2	Power Variability and Predictability.....	54
6.2.1	Possible Benefits.....	54
6.2.2	Challenges of Marine Energy and H ₂	55
6.2.3	Related Metrics To Evaluate Systems.....	55
6.3	Purifying Water for Hydrogen Production.....	55
6.3.1	Possible Benefits.....	55
6.3.2	Challenges of Marine Energy and H ₂	55
6.3.3	Related Metrics To Evaluate Systems.....	55
6.4	Environmental Effects.....	56
6.4.1	Possible Benefits.....	56
6.4.2	Challenges of Marine Energy and H ₂	56
6.4.3	Related Metrics To Evaluate Systems.....	56
6.5	Valuable Coproducts.....	56
6.5.1	Possible Benefits.....	56
6.5.2	Challenges of Marine Energy and H ₂	57
6.5.3	Related Metrics To Evaluate Systems.....	57
7	Conclusions.....	57
7.1	Identified R&D Challenges.....	58
7.2	The Future of Marine Energy-H ₂ Systems.....	59
	References.....	60

List of Figures

Figure 1. The many possible combinations for a comprehensive marine energy-H ₂ system are graphically illustrated for a subset of the possible component technologies.	2
Figure 2. Overview of technical power potential of U.S. marine energy resources.	3
Figure 3. Ocean Renewable Power Company's beta turbine generator unit (left) and a computer rendering of the Reference Model 1 device (right).	5
Figure 4. Global resource map of wave power density.....	6
Figure 5. True wave elevation and power timeseries with smoothing effects.	7
Figure 6. Seasonal variability of wave energy	8
Figure 7. The basic mechanism of common WEC technology types are conceptually illustrated	9
Figure 8. Overall geometry of RM3 (left) and operation diagram (right).....	9
Figure 9. Image of Gulf Stream resource.....	10
Figure 10. Histogram of observed velocity.....	11
Figure 11. Overall diagram of RM4 (left) and deployment diagram (right).....	11
Figure 12. A map of global OTEC resource is plotted in units of kW/(m ³ /s) of cold water pumped from 1-km depth and with assumed system efficiencies.....	12
Figure 13. A map of the known, active hydrothermal vent fields from the InterRidge Global Database of Active Submarine Hydrothermal Vent Fields. Colors indicate the reported status of the vent field (red = confirmed active, yellow = inferred active, blue = inactive).	13
Figure 14. H ₂ @Scale diagram showing hydrogen integration opportunities.....	15
Figure 15. Example diagrams of liquid alkaline (left) and PEM (right) electrolysis cells with the fundamental chemical equations included below each technology.....	18
Figure 16. Example of a solid oxide electrolysis cell.	19
Figure 17. Example of an AEM electrolyzer.	20
Figure 18. Example of DSE.	21
Figure 19. Categories of some important hydrogen storage technologies	25
Figure 20. The optimal discharge power and duration characteristics are plotted qualitatively for several prominent energy storage technologies.....	26
Figure 21. Comparison of gravimetric density and volumetric density for several fuels based on lower heating values.....	29
Figure 22. Range of power and storage requirements of the various blue economy applications potentially viable for marine energy-H ₂ implementation.....	31
Figure 23. Conceptual framework for powering small coastal observation and navigation devices using wave energy and H ₂ systems.....	34
Figure 24. Conceptual framework for powering large ocean observation platforms using ocean current energy and H ₂ systems	35
Figure 25. Conceptual framework for powering large oceangoing vessels with high-density products (like ammonia or methanol) derived from H ₂ produced from OTEC systems.....	36
Figure 26. Conceptual framework for powering UUVs using tidal/ocean current energy and H ₂ systems. Battery-operated UUVs can be recharged by a central docking and refueling station, while fuel-cell-operated UUVs can be directly fueled by subsea H ₂ storage.	38
Figure 27. Conceptual framework for powering aquaculture and algae production sites using wave energy and H ₂ systems	40
Figure 28. Conceptual framework for powering remote coastal/island communities using local marine energy resources coupled with H ₂ systems	41
Figure 29. Major subsystems of a marine energy-H ₂ project including end uses	44

List of Tables

Table 1. Several Important Aspects of Hydrogen Electrolysis Technologies.....	16
Table 2. Potential Hydrogen Storage Systems and Scale	28
Table 3. Summary of Exemplar Blue Economy Applications That Could Be Candidates for Marine Energy-H ₂ Systems	32
Table 4. Estimated Minimum Fueling Time for Battery-Electric Vehicles and Fuel Cell Electric Vehicles	38
Table 5. Publicly Available Information About Projects Using Hydrogen To Power Marine Applications	46
Table 6. Publicly Available Information About Projects Using Offshore Energy Resources To Produce Hydrogen via Electrolysis.....	48
Table 7. Paper Studies Focused on Marine and Hydrokinetic Energy to Hydrogen Feasibility and Application.....	50

1 Introduction

Decarbonizing our global economy will require a variety of solutions commensurate with the diversity of activities across the earth, and marine activities are among the most difficult to decarbonize (Chu Van et al. 2019). Operating nearly any equipment in an offshore environment is challenging for a variety of reasons including the remote locations, punishing weather effects, degradation from salt and biological growth, and potential fragility of local ecosystems. Marine energy resources have been proposed as a way to power local activities and to reduce the environmental impact relative to traditional fuel sources. Specifically, marine energy resources have the potential to complement other forms of renewable energy, such as wind and solar, due to their generation profile and geographic co-location with marine industries.

Some offshore applications are already fully electrified and use batteries that are charged from traditional energy sources and/or integrated photovoltaic solar panels. In some applications, this design paradigm is not feasible because of current constraints on the system (e.g., range or weight) that limit the adoption of existing battery technologies. In these situations, hydrogen could provide an additional energy storage vector to further enable the electrification of these challenging activities. The potential of hydrogen as an energy carrier has made it the key player in U.S. Department of Energy (DOE) initiatives such as H2@Scale (DOE 2021; 2020) and the Hydrogen Energy Earthshot (HFTO 2022). Generating hydrogen locally from marine energy resources could provide additional benefits because hydrogen production via electrolysis can utilize the highly variable power profiles that are typical of many marine energy resources.

With this in mind, we present the following report to share the results of our fact-finding in preparation for future work in the marine-energy-to-hydrogen (marine energy-H₂) space. This fact-finding process has included a working meeting with industry experts in addition to reviews of publicly available information including peer-reviewed journals, industry websites, and relevant patents. In this report, we specifically focus on a subset of marine energy resources: ocean current, tidal current, wave energy, and ocean thermal energy conversion (OTEC).

This report is also intended to summarize the results of the fact-finding process to inform the hydrogen, marine energy, and offshore end-use industries about the other aspects that could be important in evaluating the feasibility of a comprehensive marine energy-H₂ system. In support of this goal, this report includes a good deal of background information that may seem rudimentary to experts in that industry. The breadth of possible combinations of core technologies to successfully design a specific marine energy-H₂ system (see Figure 1) could fill several texts. It is also important to note that in this report we do not advocate for any specific system topology or market but instead aim to summarize the current state of knowledge and highlight opportunities and unknowns in this exciting design space.

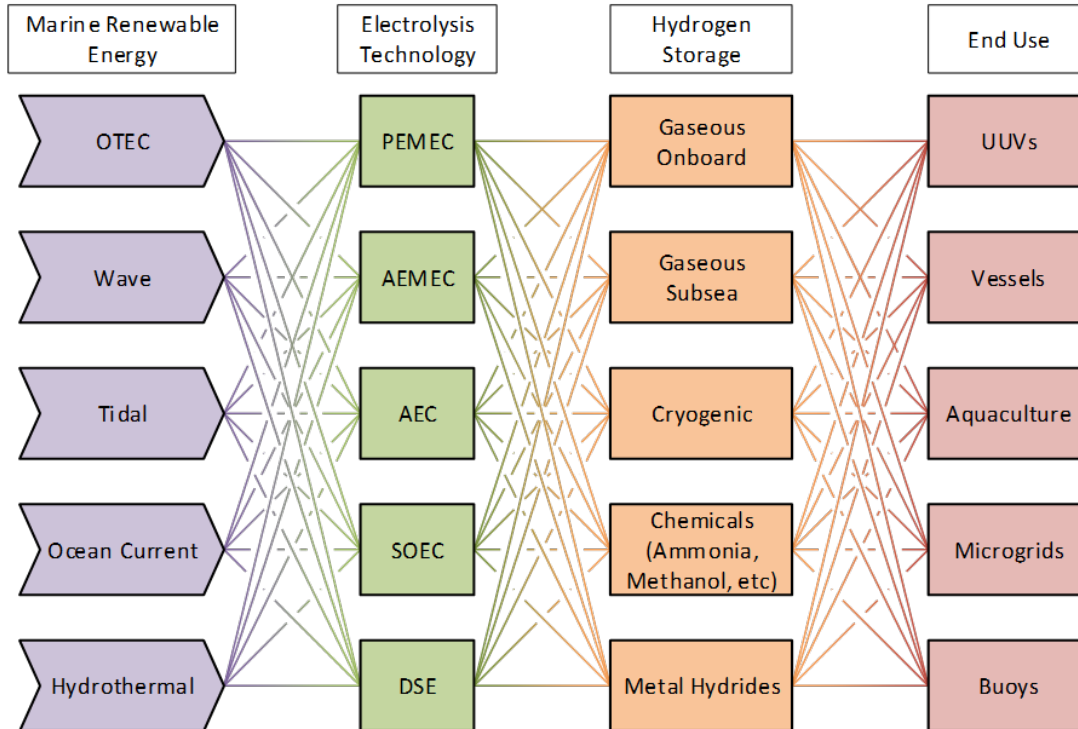

Figure 1. The many possible combinations for a comprehensive marine energy-H₂ system are graphically illustrated for a subset of the possible component technologies.

2 Marine Energy Resources

Marine energy is a diverse category of renewable energies. There are numerous technologies for capturing energy from each of the resources that fall under marine energy, including tidal, wave, ocean current, ocean thermal, and salinity gradients. Each of these have their own challenges and advantages, and each can benefit from the energy storage and end uses of hydrogen electrolysis. One primary advantage of these resources is availability. This is illustrated in Figure 2, which shows the overall available resource of each form of marine energy in and around the United States.

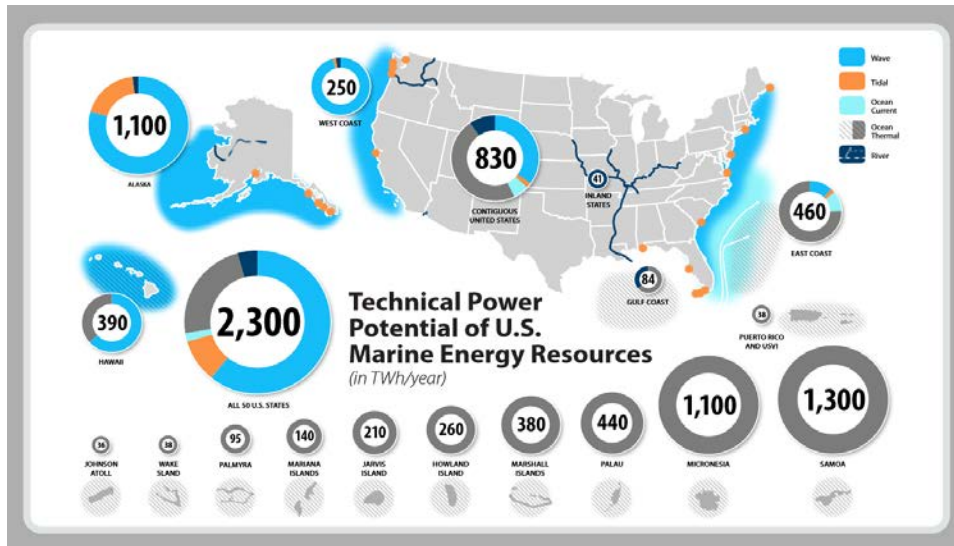

Figure 2. Overview of technical power potential of U.S. marine energy resources.

Source: Kilcher, Fogarty, and Lawson (2021)

For example, wave energy is notorious for the high ratio of peak power to average or rated power. Depending on the system design, these effects may be smoothed to a degree, but the overall fluctuations of energy at various timescales will persist through to the electrolysis system regardless of the wave energy converter type. Hydrogen generation is a potential solution to some of the fluctuations as it is a form of energy storage. It will, however, be most likely better suited to some energy profiles than others.

Until recently, the bulk of research in this field has been focused on grid-integrated technologies and the value that marine energy can provide to the electric grid (Bhatnagar et al. 2021). In 2017, DOE’s Water Power Technologies Office began work investigating non-grid opportunities such as offshore power for industry and science and remote coastal and island communities in need of reliable power (LiVecchi et al. 2019).

This section provides a brief overview of each of the marine energy resources as well as examples of how the devices that capture these resources function. This paper also includes a brief discussion of hydrothermal vents because, while these resources are not typically included in the category of marine energy, they are co-located with the marine energy resources and some end-use activities on the seafloor.

It should be noted that there are continuous advancements in the overall performance and techno-economics of each system. Following a downselect of potential resources, a more rigorous resource assessment, device selection, and techno-economic evaluation should follow.

For more information on marine energy concepts, technologies, and other topics, the Portal and Repository for Information on Marine Renewable Energy (PRIMRE) is a wiki-style collection of information maintained by DOE and other national lab partners (NREL 2021). Here you can find links to publications on Tethys, open-source data in the Marine and Hydrokinetic Data Repository, and other useful information.

2.1 Tidal Energy

Tides occur as a result of forces on the ocean by the Earth, sun, and moon. Typically, tidal energy is captured via the tidal streams that rising and falling tides create. The tidal range, tidal period, and velocity of tidal streams are all influenced by a host of factors relating to geography and time of year. These factors are largely astronomical and geographical, however, which means that although they may vary from location to location, they are very predictable and consistent over time.

2.1.1 Intensity and Location

The largest tidal range in the world is located at the Bay of Fundy in Canada, but tidal energy does not need to be massive to prove useful. Haas et al. (2011) provide data from 151 sites within the United States with mean power densities above 500 W/m². The average power available at these sites is 1,500 W/m². While this study and other available resource assessments focus on grid-scale installations, they do give an idea of where there are useful amounts of energy density. More research to produce resource assessments for smaller-scale systems could provide insights into sites that could be feasible for small systems that are not grid-connected.

Of the sites identified by Haas et al. (2011), Alaska contained most of the theoretically available power, accounting for 47 GW of the 50 GW combined total of all sites. This is due to a combination of high power density at individual sites in Alaska and the large number of sites: 89 of the 151. Other regions may have similarly high-power sites but fewer of those high-power locations. Sites with small energy markets or large distances to grid connection points are generally considered less suitable for tidal power installations (Kilcher and Thresher 2016; Van Cleve et al. 2013). Coupling tidal energy with hydrogen generation could expand the list of suitable sites because hydrogen can be stored and/or transported to be used for remote purposes. Additionally, some high-energy locations such as Alaska have an energy resource that exceeds their energy consumption.

A convenient method for locating potential tidal resources is to use previous resource assessments such as the ones already mentioned. While there are many such assessments, the following may serve as a good starting point for an investigation:

- Haas et al. (2011)
- Van Cleve et al. (2013)—Washington coast
- Kilcher and Thresher (2016)—West Coast
- Garret and Cummins (2008)—also cited in Kilcher et al. (2016)
- Khan et al. (2009)—also cited in Kilcher et al. (2016).

Additionally, capabilities are continually added to the National Renewable Energy Laboratory's (NREL's) Marine Energy Atlas tool (NREL 2020b).

2.1.2 Predictability and Variability

Tides ebb and flow in a roughly sinusoidal pattern, as they are driven by the Earth's rotation relative to the moon and sun. While geography dictates that certain areas will experience one or two periods per day, the specific cycle seen is consistent at any given location. Tides also vary in magnitude over the course of a month as a result of the changing relative positions of the Earth, moon, and sun. During "spring tides," high tides are higher and low tides are lower than usual,

resulting in larger peak current magnitudes. Differences between high and low tide heights are least during “neap tides” and are associated with the slowest peak current magnitudes.

2.1.3 Tidal Energy Converters

While tidal energy is almost always captured from fast-flowing tidal streams, the mechanism designs are still highly diverse. Tidal energy converters can take the form of augers, kites, and oscillating hydrofoils, but the most common designs are turbines much like wind energy capturing devices. Two such turbines are pictured in Figure 3.



Figure 3. Ocean Renewable Power Company's beta turbine generator unit (left) and a computer rendering of the Reference Model 1 device (right).

Sources: Ocean Renewable Power Company, NREL 24507 (left), and Neary et al. (2014) (right)

These turbines can be found in a variety of scales. For example, the Ocean Renewable Power Company TidGen pictured in Figure 3 is rated for peak power production of 600 kW, and the Reference Model 1 (RM1) device is rated at 1 MW (Neary et al. 2014). The energy production from tidal devices can be further scaled by combining multiple devices in an array.

2.2 Wave Energy

Ocean surface waves are generated by both remote and local winds. Gently rolling swells created by winds in a distant storm arrive at a given location, while rough and choppy seas at the same location are created by local winds. Every sea surface is the combination of many waves from a variety wind sources, so there is often a relatively large variability in the wave energy over a short period of time (on the order of seconds to minutes). Weather systems influence the wave resource on all timescales from seconds to hours, weeks, seasons, and interannual cycles. Analysis of decades of modeled wave data provides insights on typical wave conditions over the course of a year.

2.2.1 Intensity and Location

Geographic distribution may be the largest advantage of wave energy compared to other marine energy resources, as it is present all over the globe. However, like any other renewable resource, the intensity can vary greatly. Resource maps for wave energy typically follow large trends driven by many factors, including winds, geography, and bathymetry. The power intensity of a typical site for grid-scale wave energy devices is expected to be in the range of 10–30 kW/m²

(Babarit 2015). Projects are ongoing with the goal of producing economical designs for lower-energy sites, particularly as research and development continues for smaller-scale systems.

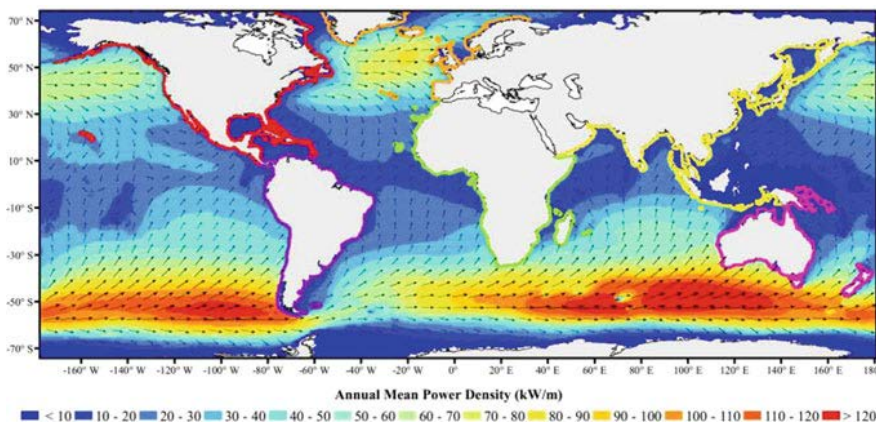

Figure 4. Global resource map of wave power density

Source: Gunn and Stock-Williams (2012)

Several resources are available to begin to select a specific site for study or to view overall trends. In addition, there is a host of published literature on specific site assessments. Some of these key resources include the following:

- Marine Energy Atlas
- National Data Buoy Center website—a network of buoys and coastal stations that measure meteorological and/or wave conditions, as well as other information
- *Marine Hydrokinetic Energy Site Identification and Ranking Methodology Part I: Wave Energy* (Kilcher and Thresher 2016).

2.2.2 Predictability and Variability

The variability of wave energy is likely one of the largest hurdles to a successful system. A considerable amount of research is aimed at developing systems that are adaptable to changing conditions, agnostic to them, and/or capable of smoothing these effects. Part of the challenge is the multiple timescales seen in wave energy variability.

At the shortest timescale, there are the individual waves. Data that capture the power information at this timescale are frequently at intervals of less than 1 second. The power available to a wave energy device will move from zero to its peak with a time period ranging from approximately 4 to 20 seconds. That peak power production can be upwards of 10 times the average power output (Yu, Tom, and Jenne 2018).

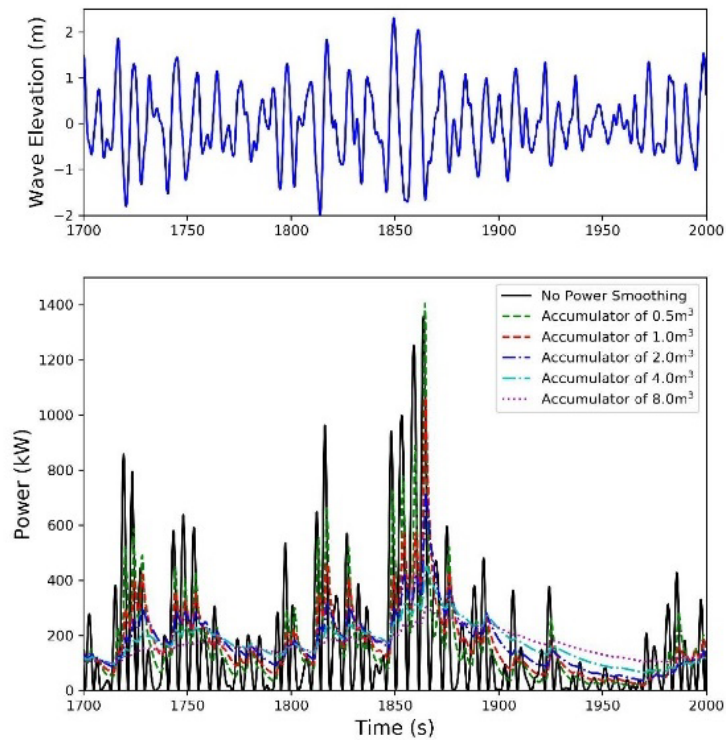

Figure 5. True wave elevation and power timeseries with smoothing effects.

Source: Yu, Tom, and Jenne (2018)

Wave conditions are typically also a combination of numerous waves of different periods and height. For this reason, wave conditions are often expressed as spectra and probability distributions.

At the next larger timescale, there is day-to-day variability. While this may take place over any number of days, there is an element of randomness to the conditions seen on a given day. This is due to the large number of factors that combine to create a given set of wave conditions.

At the longest timescale, there is seasonal variability, as shown in Figure 6. While this varies from location to location, higher-energy sea states typically occur in the winter months and lower-energy sea states occur in the summer months.

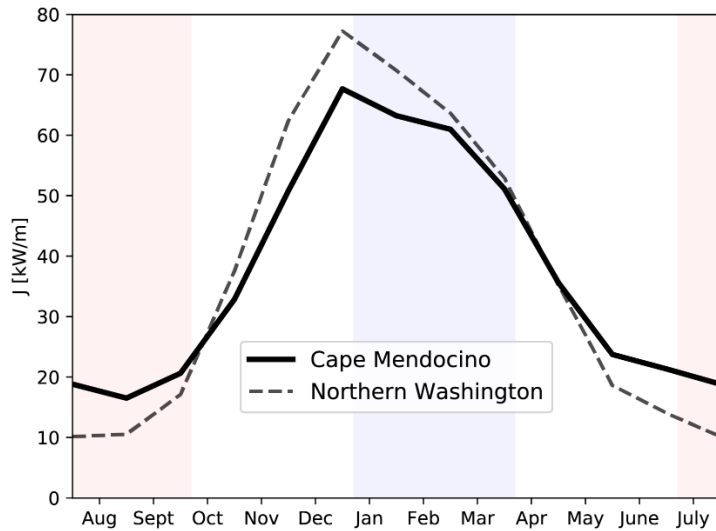

Figure 6. Seasonal variability of wave energy

Source: Yang et al. (2020)

2.2.3 Wave Energy Conversion

There are numerous wave energy converter (WEC) designs, each capturing energy present in ocean waves in different ways. Some of the most common designs are the point absorber, oscillating wave surge converter, surface attenuator, and oscillating water column. These designs are conceptually illustrated in Figure 7. Each of these designs presents different advantages and disadvantages, as well as numerous variants within each category (Babarit 2015). The fundamental challenges of wave energy, such as the harsh ocean environment and the varying nature of wave power, are seen in all of them.

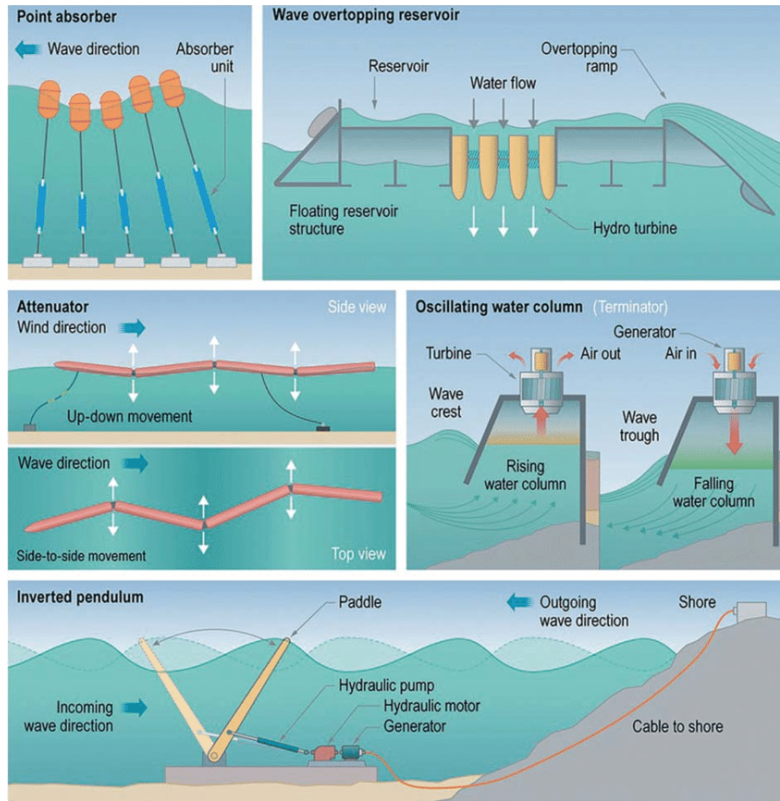

Figure 7. The basic mechanism of common WEC technology types are conceptually illustrated

Source: Augustine et al. (2012)

Wave energy devices span a range of scales, from several kilowatts to megawatts for the largest installations. Additionally, arrays can be used to expand upon the power of an individual device.

As an example of the scale of WECs, the RM3 point absorber (Figure 8) has a characteristic diameter of 20 m, and the rated power in the sea states specified at Humboldt Bay is 300 kW (Neary et al. 2014).

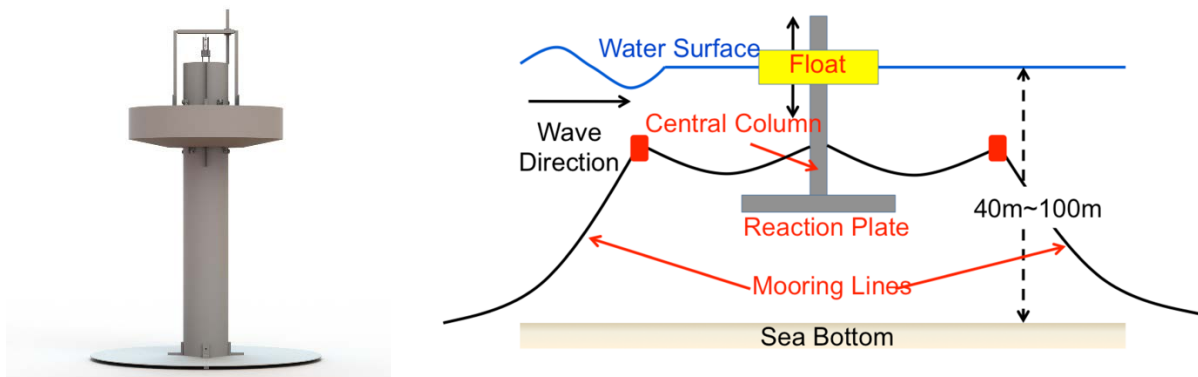

Figure 8. Overall geometry of RM3 (left) and operation diagram (right).

Source: Neary et al. (2014)

Predicting the performance of a particular device at a particular location can be challenging due to the nature of wave energy conversion, but approximations can be made.

2.3 Ocean Current Energy

Ocean current resources are relatively fast-flowing currents driven by global circulation patterns and with a long-term and well-defined structure. In the United States, the largest ocean current energy source is the Gulf Stream.

2.3.1 Intensity and Location

Ocean current energy is perhaps the most geographically restricted resource mentioned thus far. In North America, the primary ocean current energy source is the Gulf Stream, flowing from the Gulf of Mexico, around the southeast coast of Florida, and then north along the coast. The Gulf Stream is most concentrated at a relatively narrow point between Florida and Grand Bahama Island, as highlighted in Figure 9. At this location, at a depth of 50 m, the power density in this location can range from 1 to 3 kW/m² (Raye 2002).

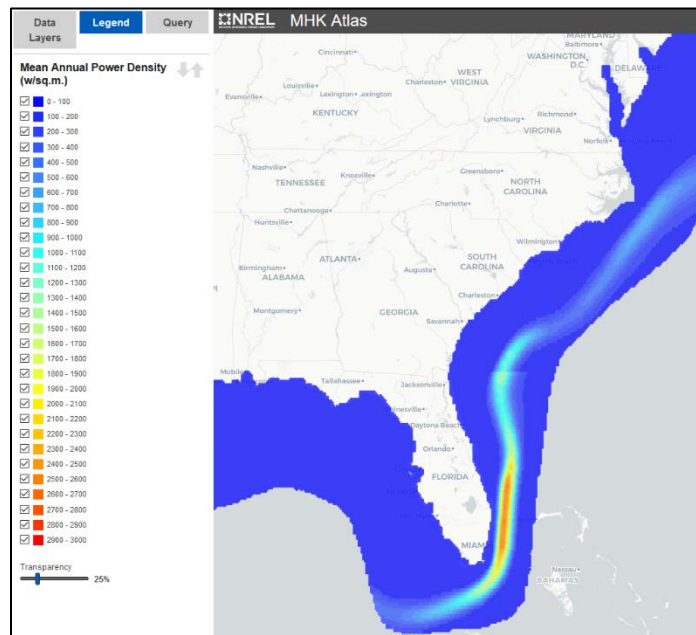

Figure 9. Image of Gulf Stream resource.

Source: NREL (2020b)

2.3.2 Predictability and Variability

The energy found in the Gulf Stream off the coast of Florida is not only at its most concentrated but also subject to the least variability in speed and location. Both current velocity and location can change over time, particularly farther north where the current can “meander” and stream velocities are less consistent. The variability of the current at the primary resource location is shown in Figure 10. Typically, flows can be expected to be about 8% greater in the summer than in the winter (Raye 2002). This position off the coast of Florida is also the most convenient location to connect to the grid for power use.

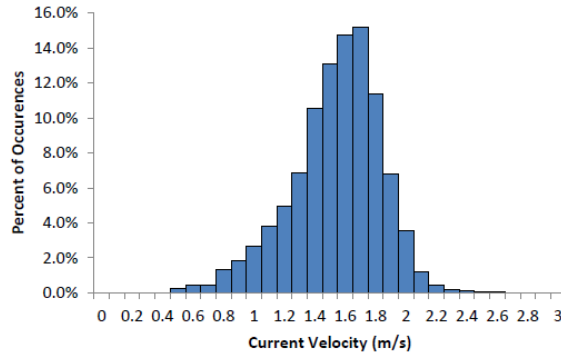

Figure 10. Histogram of observed velocity

Source: Neary et al. (2014)

2.3.3 Ocean Current Energy Conversion

As in the case of tidal energy, there are numerous devices capable of extracting energy from the flow of water caused by ocean currents, but the most prominent technologies at this time are based around turbines. The Reference Model 4 (RM4) device is an example of such a technology designed for the Gulf Stream location and is illustrated in Figure 11. One unique feature of this device is the use of a tethered “wing” rather than pilings, which is a more cost-effective method of achieving the appropriate depth and station keeping in this instance.

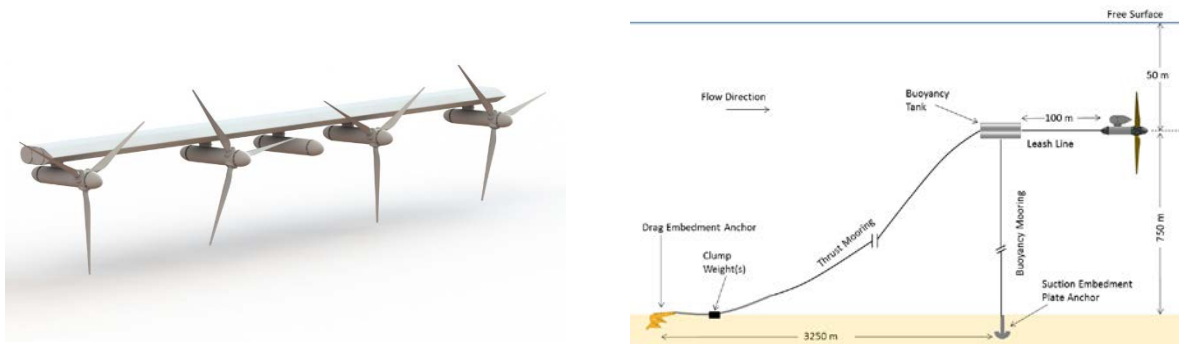

Figure 11. Overall diagram of RM4 (left) and deployment diagram (right).

Source: Neary et al. (2014)

2.4 Ocean Thermal Energy

There are two primary design paradigms for OTEC systems: open and closed cycles. In open-cycle systems, steam is generated by drawing a vacuum to flash warm seawater, and the cold subsea water is used to condense the steam after passing through a turbine (National Research Council 2013). Open-cycle systems have the added benefit of producing desalinated water as a byproduct, which would be a useful feedstock for a co-located hydrogen electrolysis system.

In closed-cycle systems, an intermediate fluid like ammonia is used as the working fluid, which permits the systems to run at higher pressures but requires a second heat exchanger (National Research Council 2013).

2.4.1 Resource Intensity and Location

OTEC operates much like a traditional power plant in that it uses a temperature differential to create vapor and drive a turbine, but rather than burning a fuel to generate heat, cold seawater is drawn from approximately 1-km depth and operates with a typical temperature difference of 20°C (36°F) (National Research Council 2013). OTEC is an attractive energy source because it is very stable and could provide a baseline power output to support grid operations. It is also broadly available, as shown in Figure 12. Unfortunately, the available temperature difference is relatively small, requiring large equipment and leading to low efficiencies (National Research Council 2013). Because of these inefficiencies and high capital costs, OTEC systems will likely only be viable at sizes greater than 100 MW except in unusual applications where the cost of energy is already high and the power requirement is low (Martel et al. 2012). This could also be acceptable for applications like shipping vessel fueling that will require enormous amounts of hydrogen (or hydrogen products) as fuel, which would in turn require a large energy source to produce the hydrogen.

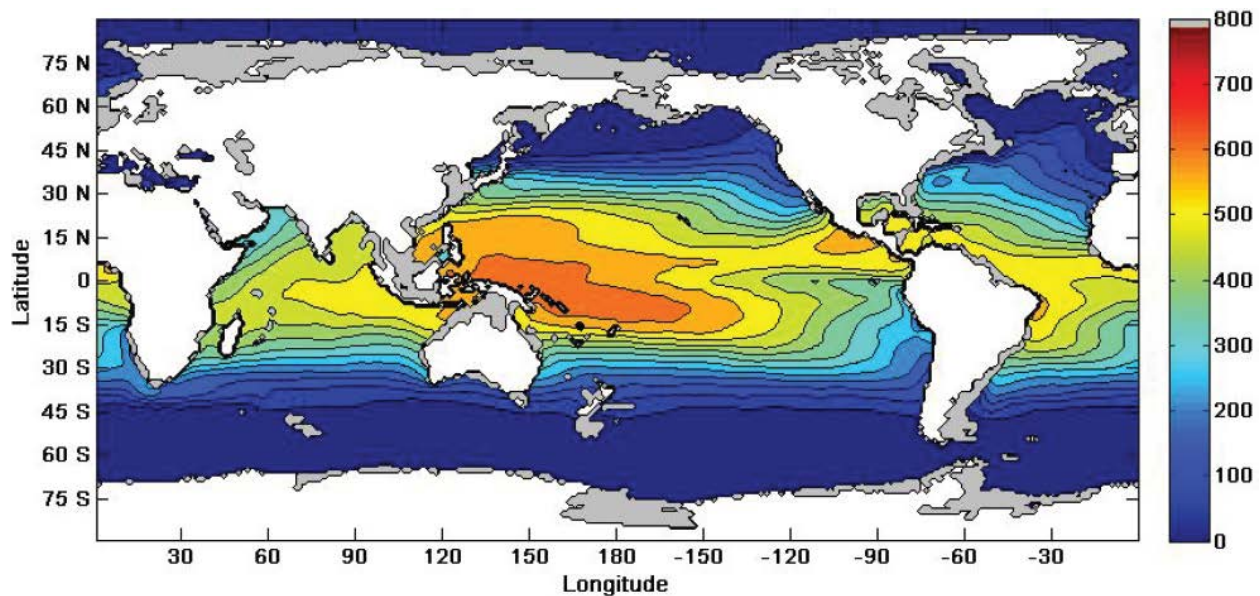

Figure 12. A map of global OTEC resource is plotted in units of kW/(m³/s) of cold water pumped from 1-km depth and with assumed system efficiencies.

Source: National Research Council (2013)

2.5 Salinity Gradients

Another opportunity for energy capture is found where fresh water meets salt water as rivers flow into the ocean. Salinity differences create an osmotic pressure differential, and several technologies exist to capitalize on this.

One technology, pressure-retarded osmosis, pumps fresh water through a semipermeable membrane toward a pressurized chamber of seawater. The increased pressure in turn drives a turbine or motor. Another technology, reverse electrodialysis, generates electricity from controlled mixing of two water sources of different salinities. The salt water and fresh water are fed through layers of ion exchange membranes, and the opposing transport of positive and negative ions creates charged poles similar to a battery (NREL 2021).

The global amount of energy from salinity gradients is estimated to be 3.1 TW, although this must be further revised to estimate the actual potential. Environmental impacts must be further studied to determine responsible levels of water extraction (NREL 2021).

2.6 Energy Resources at the Seafloor

2.6.1 Hydrothermal Vents

Hydrothermal vents are hot springs created by underwater volcanoes at spreading ridges and convergent plate boundaries. Cold seawater is heated by hot magma to temperatures over 700°F (370°C). These large temperature differentials create an attractive potential for power generation (NOAA 2020)

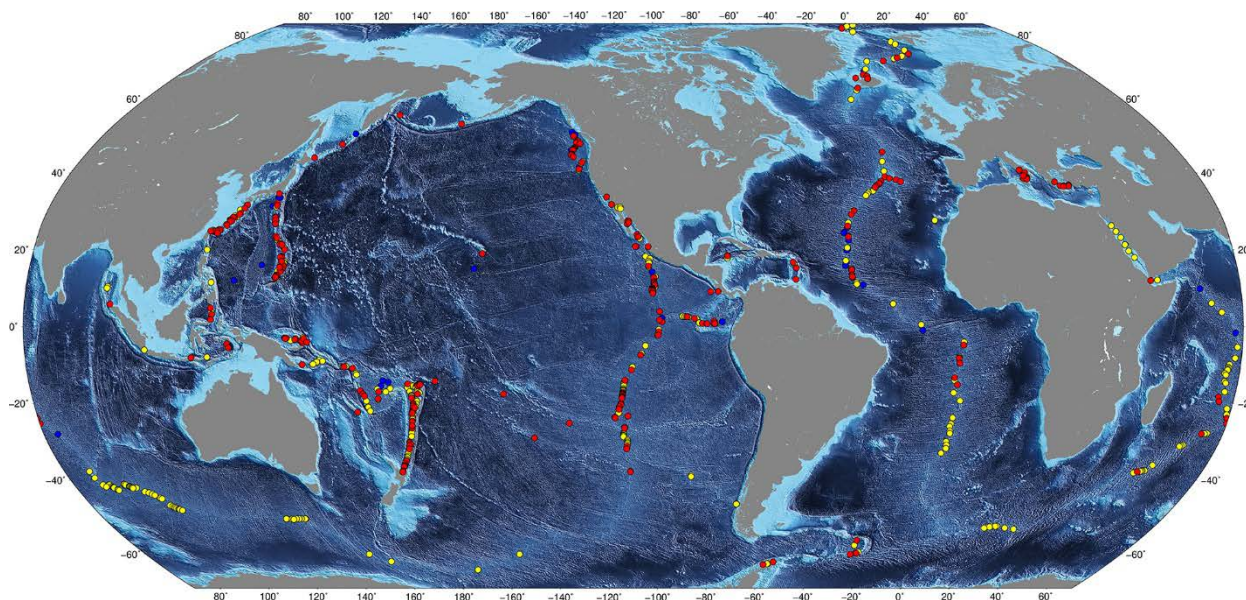

Figure 13. A map of the known, active hydrothermal vent fields from the InterRidge Global Database of Active Submarine Hydrothermal Vent Fields. Colors indicate the reported status of the vent field (red = confirmed active, yellow = inferred active, blue = inactive).

Source: Beaulieu and Szafranski (2020)

2.6.2 Methane Hydrate Deposits

Methane hydrates are structures of ice-like water molecules that have surrounded and trapped methane gas molecules in a crystalline lattice. They are naturally found in locations with low temperatures and high pressures. Two main examples are (1) within sediments in and beneath permafrost in the polar regions and (2) in shallow sediments of deep-water continental shelves.

The energy density per unit mass of methane hydrates is essentially that of regular methane gas, and while methane hydrates are a form of fossil fuel and not a renewable energy, their abundance and co-location with potential marine energy electrolysis systems make methane hydrates a relevant resource for consideration.

The global estimate of methane hydrate reserves is massive: 20 million cubic kilometers. As with most mined resources, however, not all of this is accessible. Two potentially interesting sites with large deposits of methane hydrates are the Gulf of Mexico, with 170,000 cubic kilometers,

and Alaska, which could have around 2,400 cubic kilometers of undiscovered but recoverable methane hydrates (NETL 2017).

3 Hydrogen Generation and Use

Renewably produced hydrogen¹ is a multiuse chemical that can be a much-needed energy storage mechanism (DOE 2020). Hydrogen is a critical feedstock for the chemicals industry, including for the production of liquid fuels, and it can be used as-is as a fuel for zero-emission transportation and for stationary, remote, or auxiliary power² (EERE 2020a). Any source of electricity can be leveraged to produce hydrogen for energy storage or other end-use applications. Hydrogen production by water electrolysis can be coupled with excess renewable electricity to provide large-scale energy storage (gigawatt-hours), improve grid stability, and optimize the operations of other power generators (EERE 2020a).

Producing electricity from hydrogen in a fuel cell produces only heat and water as waste products, making it an important component of future energy systems (HFTO 2021). Additionally, water electrolysis systems and fuel cells can quickly cycle on and off and ramp up or down to meet changing grid or electricity production profiles. Electrolyzers have been demonstrated to successfully operate while utilizing variable renewable energy generation profiles (e.g., wind) and providing grid support services (Mohanpurkar et al. 2017; Eichman, Harrison, and Peters 2014). As the penetration of variable renewable energy sources continues to increase, the need for energy storage is expected to grow in importance.

The potential of hydrogen as an energy carrier has made it the key player in DOE initiatives like H2@Scale and the Hydrogen Energy Earthshot (DOE 2021, 2020; HFTO 2022). Figure 14 provides a high-level overview of the potential integration opportunities provided within the H2@Scale initiative, which include marine energy production as renewable resources and maritime as an end use of hydrogen through transportation, synthetic fuels, ammonia production, and other processes. Hydrogen provides an energy storage mechanism for marine energy that can be transported to reach a variety of end users.

¹ Low-carbon or carbon-neutral hydrogen production can be accomplished with steam reformation of fossil resources with carbon capture utilization and storage, biomass/waste, or water splitting.

² Hydrogen is used across sectors, typically as a compressed gas or cryogenic liquid.

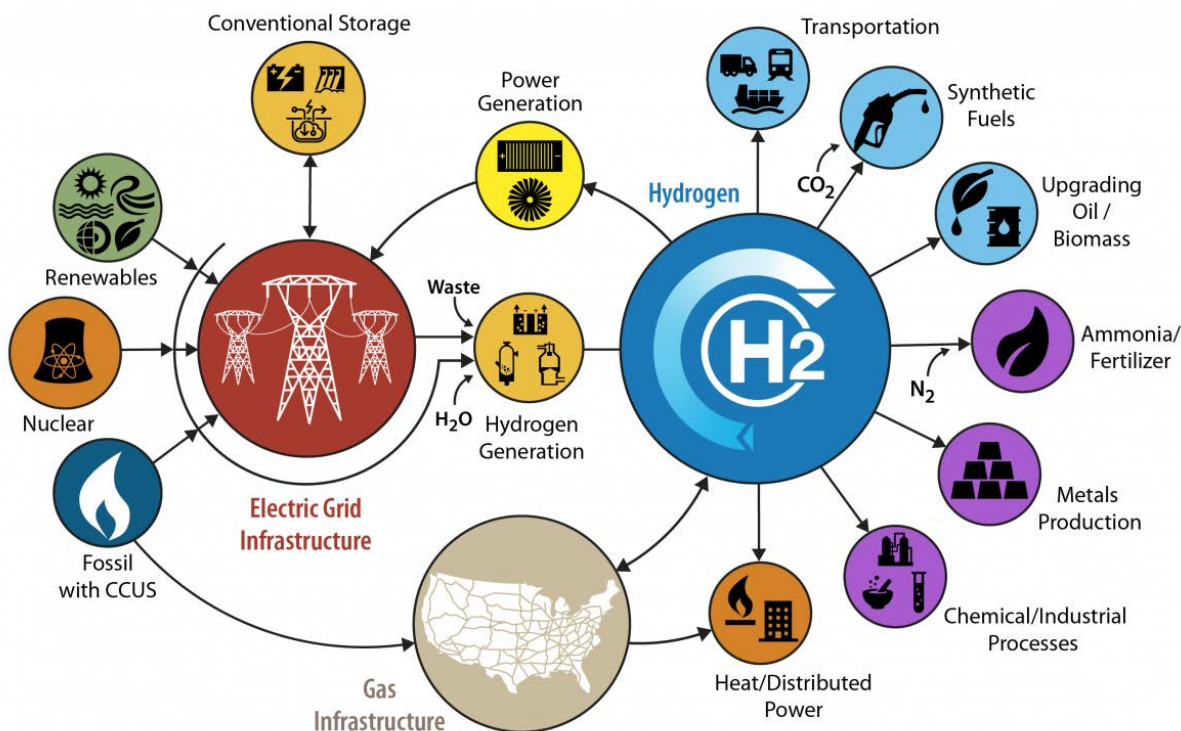

Figure 14. H2@Scale diagram showing hydrogen integration opportunities.

Source: DOE (2021)

3.1 Electrolysis Technologies

Water electrolysis is the process of splitting water to produce hydrogen and oxygen gas (HFTO 2021; DOE 2020). A fundamental building block of combined marine energy-H₂ systems is a low-temperature water electrolysis unit. In the near term (<5 years), commercially available low-temperature water electrolysis methods are alkaline electrolysis³ and proton exchange membrane (PEM) electrolysis (Schmidt 2017). Solid oxide or high-temperature electrolysis and high-pressure PEM electrolysis are medium-term technologies, and direct seawater electrolysis (DSE), high-pressure PEM electrolysis, and anion exchange membrane (AEM) electrolysis are emerging—and potentially game changing—long-term technologies (d’Amore-Domenech and Leo 2019; Dresp et al. 2019; Vincent and Bessarabov 2018; Habermeyer et al. 2018; Martin et al. 2019; IRENA 2020). The following sections provide an overview of critical considerations for near-term marine energy-H₂ integration, the advantages and challenges of near-term electrolysis technologies, the cost of near-term hydrogen production via water electrolysis, packaging considerations for marine electrolysis deployments, and promising future water electrolysis technology options.

3.2 Near-Term Marine Energy-H₂ Integration

The two most mature electrolysis technology options for near-term deployments of marine energy-H₂ are alkaline and PEM electrolysis (Schmidt 2017; IRENA 2020). Table 1 outlines the

³ In this report, the general use of alkaline electrolysis refers to conventional liquid alkaline electrolysis with a liquid electrolyte such as KOH. Anion exchange membrane alkaline electrolysis will be referred to as AEM.

key parameters of these two technologies. Many characteristics of these two electrolysis methods are similar. Critical differences are found in the typical outlet pressure, catalyst material, water quality requirements, and system startup/shutdown capabilities. The specific design of an integrated marine energy-H₂ system would play a role in determining the optimal technology. Some of these critical design parameters include:

- The specific hydrokinetic source (e.g., tidal).
- Whether there is an array or single marine energy device.
- Whether the electrolysis system is a single unit per marine energy device or centralized.
- Whether the electrolysis system is located onshore or offshore.
- The storage/transport pressure of H₂.
- The end use of H₂.
- The relative sizing of the marine energy and water electrolysis system relative to one another.

In the end, this will likely be an economic decision. The chosen electrolysis technology will be able to reliably operate in the deployed environment, can best match the deployed marine energy system, will produce the most useful hydrogen, and can do all of this at the lowest cost.

Table 1. Several Important Aspects of Hydrogen Electrolysis Technologies

Values are compiled from the following sources: IRENA 2020; Dresp et al. 2019; Tong et al. 2020; Peterson, Vickers, and DeSantis 2020a, 2020b; Vincent and Bessarabov 2018.

Technology	Alkaline	PEM	Solid Oxide	AEM	DSE
Operating temperature	60°C–100°C	50°C–90°C	650°C–1,000°C	40°C–60°C	TBD
Typical outlet pressure	<435 psi (3 MPa)	<2,900 psi (20 MPa) ^a	<363 psi (2.5 MPa)	<508 psi (3.5 MPa)	-
System electrical conversion (kWh/kg) ^b	50–79	50–83	39.8–50 ^c	57–69	-
Response speed	Seconds	Milliseconds	Seconds	Milliseconds	-
Electrolyte	Aqueous alkaline electrolyte (e.g., 20–40 wt % KOH)	Polymer membrane (e.g., Nafion)	Ceramic membrane (e.g., yttria stabilized zirconia)	Polymer membrane (e.g., quaternary ammonia polysulfone)	Seawater
Demonstrated stack durability	60,000–90,000 h	20,000–80,000 h	<35,000 h	>5,000 h	-
Typical catalyst materials (anode/cathode)	Ni, Ni-Co alloys/Ni, Ni-Mo alloys	RuO ₂ , IrO ₂ /Pt, Pt-Pd	Ni-YSZ/LSM-YSZ	Co/Ni/Ir-based	-
Feedstock and purity requirements	Water	Deionized water	Steam	Deionized water	Seawater

Technology	Alkaline	PEM	Solid Oxide	AEM	DSE
Output H ₂ gas purity (%)	>99.3	>99.9	>99.9	>99.9	-
Cold start time (min)	<60	<20	<60–600	<20	-
Lower dynamic range (%)	10–40	0–10	30	5	-

^a High-pressure PEM electrolysis, >70-MPa outlet pressure has been demonstrated (Martin et al. 2019)

^b The higher heating value and lower heating value of hydrogen are 39.4 kWh/kg and 33.3 kWh/kg, respectively

^c Additional thermal energy usage of 5 to 12 kWh/kg (IRENA 2020; Schmidt 2017; Peterson, Vickers, and DeSantis 2020a).

3.2.1 Liquid Alkaline Electrolysis

Alkaline electrolysis is the most mature electrolysis technology (IRENA 2020; Schmidt 2017). Advantages include common catalyst metals, less stringent water quality requirements, and low system material costs due to lower operating pressures. Challenges for alkaline electrolysis include slightly lower efficiency than PEM, low operating current density (normally below 1 A/cm²), low differential (O₂ to H₂) operating pressure, dynamic operation limitations, potential impurities in the produced hydrogen gas, and the use of a caustic liquid electrolyte (e.g., KOH or NaOH) (IRENA 2020; Schmidt 2017; Vincent and Bessarabov 2018). Limitations in dynamic operation due to potential hydrogen gas purity challenges have been shown to exist during shutdown and startup (on/off operation) (Schmidt 2017). Alkaline electrolyzers perform well in small-scale dynamic operational testing, albeit slightly slower than PEM electrolyzers (Eichman, Harrison, and Peters 2014). As a stack of electrolytic cells, both types of electrolyzers have a fast response time, noting that much of the response time is dependent on the control system and power supply. Regular maintenance is required to replenish the liquid electrolyte (d'Amore-Domenech and Leo 2019). This requires appropriate considerations for handling and storing a caustic liquid. The quality of the input water added to the liquid electrolyte is normally between 500 and 1,000 kΩ-cm. Impurities in the input water can cause the need for regular renewal of the liquid electrolyte (d'Amore-Domenech and Leo 2019).

3.2.2 PEM Electrolysis

The advantages of PEM electrolysis include high current density, good cell efficiency, high purity of hydrogen gas, electrochemically compressed hydrogen production (nominally 30 bar), and fast dynamic operation capabilities (IRENA 2020; Schmidt 2017; Vincent and Bessarabov 2018). Existing electrolysis stacks are operating at current densities of approximately 3 A/cm² with potential operation at much higher current densities (IRENA 2020). PEM electrolyzer stacks can operate with differential pressures between the anode and cathode (e.g., 10 bar and 3 MPa, respectively). Some of the challenges for PEM electrolysis include expensive platinum catalysts, fluorinated membrane materials, stringent water quality requirements, additional complexity and material cost for pressurized systems, and potential back diffusion across the membrane (Schmidt 2017; Vincent and Bessarabov 2018). Due to the low pH in the vicinity of the hydrated Nafion membrane, noble metals like platinum are required to be used as the catalyst (Vincent and Bessarabov 2018). The resistivity of the supply of deionized water is required to be greater than 1 MΩ-cm. The purity of the feed water prevents premature efficiency degradation due to blocked reaction sites. The lower operational limit of a PEM electrolyzer is about 10% of the nameplate capacity. This ensures that there is enough electrical driving force to limit

hydrogen back diffusion across the membrane (d’Amore-Domenech and Leo 2019). Diagrams of an alkaline and PEM electrolyzer, as well as the fundamental chemical equations, are shown in Figure 15. Reversible PEM fuel cells may be an efficient way to enable energy storage by electrolysis and production with a fuel cell with a single stack. Additional information on reversible fuel cells can be found on the DOE Reversible Fuel Cells Workshop webpage (HFTO 2011).

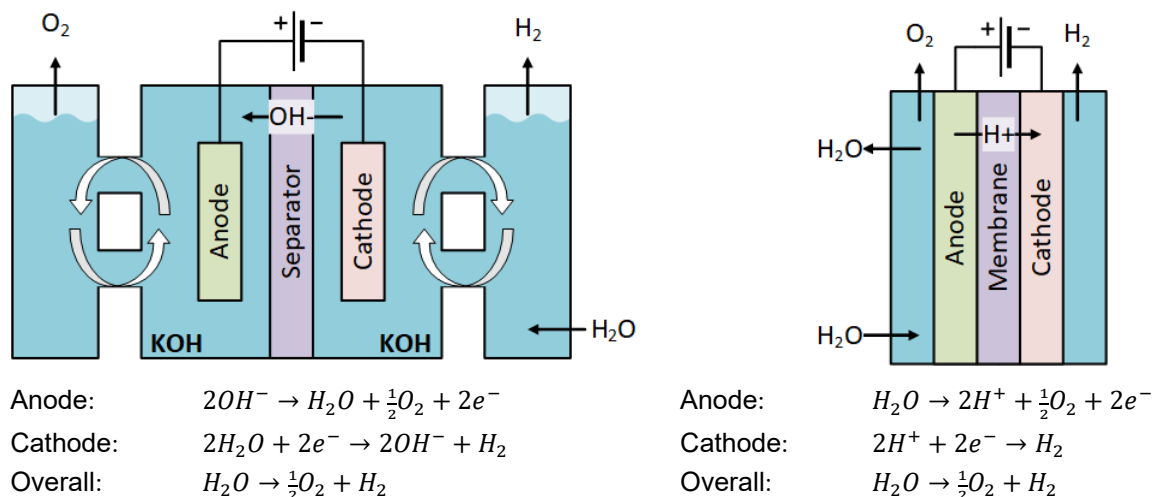

Figure 15. Example diagrams of liquid alkaline (left) and PEM (right) electrolysis cells with the fundamental chemical equations included below each technology.

Based on Schmidt (2017)

3.3 Medium- and Long-Term Water Electrolysis Options

3.3.1 Solid Oxide Electrolysis

Solid oxide electrolysis or high-temperature electrolysis is an emerging technology with a technology readiness level of 6 (Habermeyer et al. 2018). This makes solid oxide electrolysis a medium-term technology that needs further research for successful commercial deployment. A solid oxide electrolysis cell (SOEC) is composed of a solid ceramic electrolyte and two electrodes. High-temperature operation at 650°C to 1,000°C (1,200°F to 1,830°F) enables ions (O^{2-}) to travel through the ceramic electrolyte (d’Amore-Domenech and Leo 2019). High-temperature operation also enables much higher electrical efficiency than alkaline or PEM electrolysis (IRENA 2020; Schmidt 2017). The improvement in efficiency is directly related to the high-temperature operation, which requires a heat source providing approximately 5–12 kWh/kg of additional thermal energy (IRENA 2020; Schmidt 2017; Peterson, Vickers, and DeSantis 2020a). The efficiency advantage of solid oxide electrolysis can be taken advantage of when co-located with a source of excess or energetically cheap heat. Ideally, waste heat from another application would be used to heat the electrolysis system. For a marine deployment, the co-location of a solid oxide electrolyzer and a heat source adds additional complexity. Like PEM, a solid oxide system can be reversed to create solid oxide fuel cells to produce electricity from hydrogen. Solid oxide fuel cells also have a higher efficiency and heat requirement. A simplified diagram of an SOEC and the chemical reaction taking place in a solid oxide electrolyzer is shown in Figure 16.

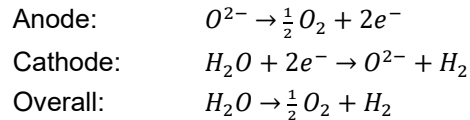
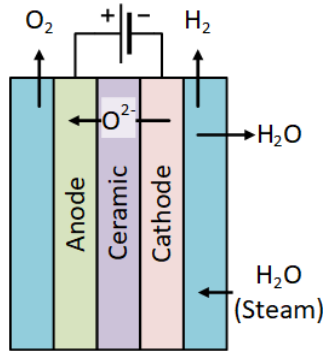

Figure 16. Example of a solid oxide electrolysis cell.

Based upon Schmidt (2017)

The projected cost estimates for high-temperature electrolysis technologies assume an annual system production capacity of 700 MW/yr. The current production of solid oxide electrolysis systems is less than two orders of magnitude less than the projected estimate of 700 MW/yr (Peterson, Vickers, and DeSantis 2020a). For the high-temperature electrolysis analysis published in the DOE Hydrogen Program records, the main driver of hydrogen production cost was the price of electricity. This shows the importance of utilizing low-cost electricity from renewables or off-peak grid sources for any type of electrolysis. Currently, the capital cost of high-temperature, solid oxide electrolysis is also a major contributor to the lifetime cost of the system, but this is expected to decrease significantly with increased scale and technical maturity (IRENA 2020; Schmidt 2017; Peterson, Vickers, and DeSantis 2020a). Advantages of solid oxide electrolysis include high electrical efficiency, low material cost, and potential to utilize waste heat streams (Schmidt 2017; IRENA 2020). Challenges include lower technology readiness level, material degradation from operation at high temperature, limitations to dynamic operation, and operation at high temperature (d'Amore-Domenech and Leo 2019; Schmidt 2017). Research is ongoing to move this technology into the commercial market. Reversible solid oxide fuel cells may be an efficient way to enable energy storage by electrolysis and production with a fuel cell with a single stack. Additional information on reversible fuel cells can be found in the summary report from the Reversible Fuel Cells Workshop hosted by NREL in 2011 (HFTO 2011).

3.3.2 High-Pressure PEM Electrolysis

High-pressure PEM electrolysis is another medium-term technology that has been demonstrated at the laboratory scale. This branch of PEM electrolysis has taken the standard PEM electrolysis platform and redesigned it for high-pressure output of the hydrogen gas (>70 MPa/10,000 psi) (Martin et al. 2019). High-pressure electrolysis has the potential to play a significant role in the gaseous vehicle fueling market because the mechanical compression of hydrogen gas is a significant contributor to capital and operational costs. The high-electrochemical-pressure PEM electrolysis has the potential to change how hydrogen infrastructure systems operate and are designed. Challenges of high-pressure electrolysis mainly consist of system design, material selection, and safety considerations. The system must be designed for high-pressure hydrogen

service (>70 MPa) and the near-ambient-pressure oxygen that is produced. The significant pressure differential between the anode and cathode drives a higher rate of hydrogen back diffusion across the polymer membrane when compared to other electrolysis systems. Additional safety monitoring and operational requirements are needed to ensure a potentially dangerous mixture of hydrogen and oxygen is not created. Furthermore, there is a significant difference in the packaging and design needed for a system producing hydrogen at 3 MPa compared to 70 MPa. The demonstration of a high-pressure PEM electrolyzer in the laboratory setting shows that these challenges can be overcome (Martin et al. 2019).

3.3.3 AEM Electrolysis

AEM electrolysis is a developing electrolysis method. Much of the recent research is focused on membrane and catalyst development (Vincent and Bessarabov 2018). AEM devices are similar in design to PEM devices, but anions are transported across the membrane instead of protons. This requires a membrane that is basic and provides a transport path for hydroxide ions (Vincent and Bessarabov 2018). This enables AEM electrolysis to utilize low-cost catalyst metals. AEM electrolysis can have high-pressure, pure hydrogen output. Some of the current challenges with AEM are low current densities, durability, and membrane degradation (Vincent and Bessarabov 2018). In the future, AEM electrolysis could have many of the advantages of PEM electrolysis with a low-cost metal catalyst like alkaline electrolysis. A breakdown of the chemical reaction taking place is shown in Figure 17.

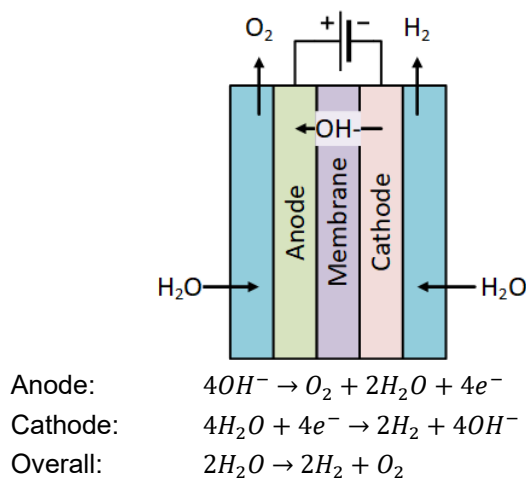

Figure 17. Example of an AEM electrolyzer.

Based upon Schmidt (2017)

3.3.4 Direct Seawater Electrolysis

DSE, as illustrated in Figure 18, utilizes relatively unfiltered seawater as both the feedstock and the electrolyte (d'Amore-Domenech and Leo 2019; Dresp et al. 2019; Tong et al. 2020). This technology is also at a low technology readiness level but is promising when considering the future of marine energy-H₂ applications. DSE could eliminate the need to desalinate or deionize the water feedstock. This electrolysis method, like PEM electrolysis, can be achieved through transport of protons through a membrane. One of the main challenges of DSE is that at normal current densities, the chlorine evolution reaction is dominant over the desired oxygen evolution

reaction. The oxygen evolution reaction is only dominant at very low or high current densities (Dresp et al. 2019):

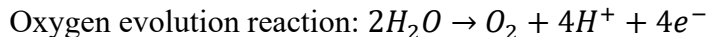
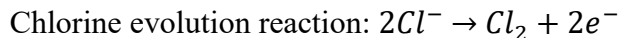

The chlorine evolution reaction can produce unwanted hazardous gas such as chlorine or hypochlorite (d'Amore-Domenech and Leo 2019; Dresp et al. 2019). To attempt to resolve this challenge and produce the desired chemical reaction, research and development is focused on selective membranes or separators, selective catalysts, and pH control of the membrane (Dresp et al. 2019). An additional path may be to investigate DSE for chlorine gas production as an additional product stream. In the future, DSE could be an ideal electrolysis method for marine energy-H₂ integration. More time is needed for research and development before a commercial system can be reliably developed and deployed at scale.

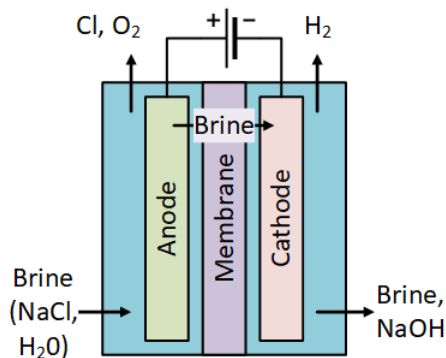

Figure 18. Example of DSE.

Based upon Schmidt (2017)

3.4 Balance of Plant

Each electrolysis method requires a different balance of plant (BOP) based on the operating temperature, electrolyte composition, product separation, and cooling method. Similar components are needed for both alkaline and PEM electrolysis BOP: pumps to feed the electrolyte (alkaline) or deionized water (PEM) to the anode of the electrolyzer stack, control valves, heat exchangers, phase separators, power electronics to provide a DC supply to the electrolyzer stack, and dryers (Brauns and Turek 2020; Ayers et al. 2010; Mayyas et al. 2019). Ayers et al. (2010) studied the subsystem contributions to the total capital cost for a 13-kg/day PEM electrolyzer and found that 53% of the cost was attributed to the electrolysis stack, 32% to the BOP, and 15% to the power supplies. Additional advantages are anticipated with scaling up to megawatt-scale electrolysis (1 MW of electrolyzer capacity roughly equates to 450 kg H₂/day production) because the capital cost associated with the BOP, as a fraction of the total cost, is predicted to shrink as the total capacity increases (Ayers et al. 2010). Mayyas et al. (2019) published research on a manufacturing cost model for PEM electrolyzers that outlines BOP and stack component costs and opportunities for improvement. They estimated that the BOP (not including the power supply) for a 1-MW PEM electrolysis system would account for 33% of the cost, with the power supply accounting for 33% and the stack the final 33%. Reduction in stack

material costs, which begin to dominate at high production levels, could be the cause of the relative reduction in stack cost relative to the power supplies and BOP (Mayyas et al. 2019). Drying hydrogen gas comes with additional system-level efficiency losses and is required for standard mechanical compression technology, but other end uses may not require the same level of drying.

3.4.1 Electrical Integration and Operation Considerations

For any type of electrolyzer, the design and operation of the power electronics will play a significant role. Integration of the PEM electrolyzer and the power electronics is another critical subsystem. Electrolyzer stacks run on DC power, while the BOP equipment (traditionally) requires grid-compatible AC power. The required DC power for the stack is dependent upon the number of cells as well as the area of each cell. With a marine energy power source, the power electronics have the potential to be complex. Depending on the power profile and array size of the marine energy technology being used, the power electronics system may need to rectify and scale the supply into a usable DC voltage. The selected control system and power supply play a critical role in the electrolyzer response time and thus the compatibility with marine energy resources. Marine energy system design will also guide the sizing of the power supply, electrolysis stack, and the associated BOP. Research done in collaboration between Idaho National Laboratory and NREL has demonstrated the response of a 250-kW PEM electrolyzer following utility demand profiles (Mohanpurkar et al. 2017). This work, in addition to the work by Eichman, Harrison, and Peters (2014), demonstrates the dynamic operation capabilities of real electrolysis systems.

Although electrolyzers are capable of operating with an approximate 10:1 turndown, there is an impact to the system efficiency. Harrison et al. (2009) showed that system efficiency of a small-scale (<10-kW) electrolyzer decreases as stack power is decreased, where the system efficiency was reported to be 49% (lower heating value) and 57% (higher heating value). The primary reason for this decrease is that the BOP load remains (essentially) the same while the amount of hydrogen produced falls with decreasing stack power. Kotowicz, Węcel, and Jurczyk (2018) produced a more detailed evaluation of the efficiency at different operational conditions and found similar patterns wherein efficiency decreased at low power values. Power system interaction and efficiency is one of the critical aspects of marine energy-H₂ system integration that requires further in-depth research and techno-economic analysis for optimization.

3.4.2 Desalination Providing Feed Water for Electrolysis

Many desalination systems, particularly at this scale, use reverse osmosis to remove contaminants from the water. These systems are readily available and simple to incorporate but with limitations. Pretreatment filters that are used to extend the life of reverse osmosis membranes must either be self-cleaning, which adds complexity, or periodically replaced, which requires access to the system for maintenance.

Reverse osmosis systems are less able to react to very fast transients when compared to electrolysis devices that would consume the produced water (Kim, Chen, and Garcia 2016). Because of this mismatch in time responses, a buffer tank that stores deionized water is required to damp the demand for deionized water when the electrolyzer is operating in a highly dynamic manner. The ideal sizing of this tank will depend on economic constraints based on the expected variability of the system as a whole. The reverse osmosis system may also be able to accept

excess power during times of especially high production above the rated capacity of the electrolyzer.

Another limitation is in the water quality required for electrolysis relative to the supplied water. Typical systems will reject around 99.5% of the dissolved salts, producing water with a concentration of total dissolved solids around 200 ppm. This correlates to a conductivity of roughly 3.33 k Ω -cm (300 μ S/cm). The required conductivity for alkaline and PEM electrolysis is roughly 500–1,000 k Ω -cm (1–2 μ S/cm) and 1 M Ω -cm (1 μ S/cm), respectively. Further treatment will be required to reach these water quality requirements. This could take the form of either an additional reverse osmosis process, ion exchange filters, or thermal purification. Evaluating this difference will be a key goal of the investigation. Impure water can lead to loss of system performance and increased maintenance.

3.4.3 Packaging Considerations for Marine Deployments of Electrolysis

When considering an integrated marine energy-H₂ system, the packaging of the electrolyzer stack and BOP for a marine environment becomes critical. Marine environments are corrosive, and special consideration is needed to prevent system damage (Di Blasi et al. 2013). Therefore, correct material selection for a corrosive environment is critical. Due to the production of hydrogen gas at pressure, nearly all the components on a PEM electrolysis stack are made of stainless steel, which provides corrosion protection. Even stainless-steel components could be damaged if not protected correctly during long-term deployments. Alkaline electrolysis systems have more material flexibility due in part to the low balanced pressure operation.

Packaging will also need to be able to withstand the wave motion for a potential floating sea deployment. The lack of moving parts within a PEM electrolysis stack and pressurized flow across the anode limit the impact of the swell motion on the stack. Swell motion could impact an alkaline electrolysis system due to the use of the liquid electrolyte. Containers and liquid levels would need to be maintained such that operation of the alkaline electrolyzer is not negatively impacted. Sea swell could affect the performance of the liquid/gas phase separators for both alkaline and PEM electrolysis. Fossil industry equipment suppliers have extensive experience designing and running pumps and separators in marine environments. Their experience should be leveraged to design and package systems, including all the pumps and separators needed for the electrolysis system and the BOP.

Underwater deployments, if designed appropriately, are another potential option for avoiding wave motion. An underwater deployment would require significant adaptation from current terrestrial water electrolyzer packaging designs, but the fundamentals of the technology would likely not be changed. Additionally, an underwater deployment may be more stable due to protection from adverse weather and surface conditions.

3.4.4 Compression

Hydrogen compression enables the gas to be stored at a higher volumetric energy density. Although hydrogen has a high energy content by weight, 120 MJ/kg (lower heating value), the energy density by volume is comparatively low relative to other fuels like methane and ammonia (Dias et al. 2020). To improve the volumetric energy density of hydrogen gas, compression is used. In the transportation sector, hydrogen fuel cell electric vehicles are filled with hydrogen gas to a nominal pressure of 70 MPa (10,000 psi). High-pressure gas storage is critical for fuel

cell electric vehicles to be range-competitive with traditional internal combustion engine vehicles. Depending on the storage technology, transport method, or end use, different pressures of hydrogen gas may be required. If deep-sea or underwater electrolysis is used, there is a compression advantage due to the depth. This added compression can be leveraged without extra cost in the electrolysis system and storage.

Hydrogen compression technologies can be put into two general subgroups: mechanical and electrochemical compressors. Mechanical compressors are the more mature technology, while electrochemical compressors have reached the demonstration or early commercialization phase. Experience from the oil and gas industry could be leveraged to package and maintain mechanical compressors in a marine environment. Testing of a mechanical compressor at NREL found an average efficiency of 3.54 kWh/kg (Terlip, Harrison, and Peters 2015). This testing was at constant suction pressure, used a power factor of 0.8, and included coolant pump and radiator power consumption (1.86 kW) (Terlip, Harrison, and Peters 2015). This matches the NREL composite data products from 2020, which showed the average compression energy to be 1.4 and 3.32 kWh/kg for retail-only and all (retail and non-retail) hydrogen fueling stations, respectively (NREL 2020a, 2018). Although an integrated marine energy-H₂ system will not be identical in design and operation to the hydrogen fueling station data shown in the composite data products, these data provide insight into the potential energy requirements in similar applications.

Electrochemical compressors have a potential reliability advantage due to the lack of moving parts, especially in a marine environment. Packaging would be very similar to that of a PEM electrolysis stack. Another potential advantage of electrochemical compressors is their ability to adapt to rapid changes in load (Bouwman 2016). Electrochemical hydrogen compression could potentially be able to utilize the variable output of a WEC or other marine energy device along with the electrolyzer, allowing for enhanced power profile peak shaving capabilities. This technology must mature before becoming available for reliable deployment. Literature states that the efficiency of electrochemical hydrogen compressors could theoretically be approximately 3 kWh/kg (Bouwman 2016).

3.4.5 Typical Round-Trip Efficiency

The round-trip efficiency of electricity to hydrogen and back to electricity is dependent on the specific system components and end-use applications (Schaber, Mazza, and Hammerschlag 2004; Dias et al. 2020). The round-trip efficiency of hydrogen production by low-temperature water electrolysis, mechanical compression to 700-bar storage, and electricity generation by a fuel cell can be estimated to be approximately 30% to 40%. This number is calculated by assuming that the energy cost of electrolysis is 50–55 kWh/kg, compression consumes another 2–4 kWh/kg, and the fuel cell produces 20 kWh/kg of electricity (NREL 2020a, 2018; Schmidt 2017; Penev 2013; EERE 2016). This calculation is one basic example of a backup power or grid support system. Liquefaction of hydrogen, an energy-intensive process, would lead to a lower round-trip efficiency (Dias et al. 2020). Sections 3.5 and 4 outline additional hydrogen carrier fuels and systems with different processes that would affect the round-trip efficiency and resulting commodity value. This round-trip efficiency is expected to be increased with the development of higher-efficiency electrolyzer and fuel cell/reversible fuel cell technologies (e.g., SOEC/solid oxide fuel cell) and is less of a factor in the generation of hydrogen as an industrial chemical commodity.

3.5 Hydrogen Storage

Due to the low volumetric energy density of hydrogen, creating compact methods of storage is challenging (DOE 2020). To solve this problem, a variety of methods of hydrogen storage technologies exist or are being developed. Figure 19 identifies some currently available subgroups of hydrogen storage technologies. Physical-based storage is a tank or containerized storage for gaseous or liquid hydrogen. This type of storage can include geologic features such as salt caverns, pipelines, and steel or composite tanks (EERE 2020b). Material-based storage includes processes that store hydrogen in chemical compounds (DOE 2020). Examples of material-based storage include storing hydrogen as other fuels or carriers such as ammonia and methane, or in specialized materials like metal hydrides (Dias et al. 2020; DOE 2020). Section 3.5.2 provides further detail on one potential end-use opportunity of storage by chemical conversion. The variety of material-based storage technologies provides versatility and potentially unique solutions for future storage systems (EERE 2020b). Ongoing research will likely continue to improve and develop material-based storage technology. The storage of hydrogen and hydrogen carriers excels in the areas of long discharge duration and high discharge power, as shown in Figure 20 (Ruth et al. 2020). With increasing energy production using renewable energy resources, there is a need for long-duration storage that could be met by hydrogen.

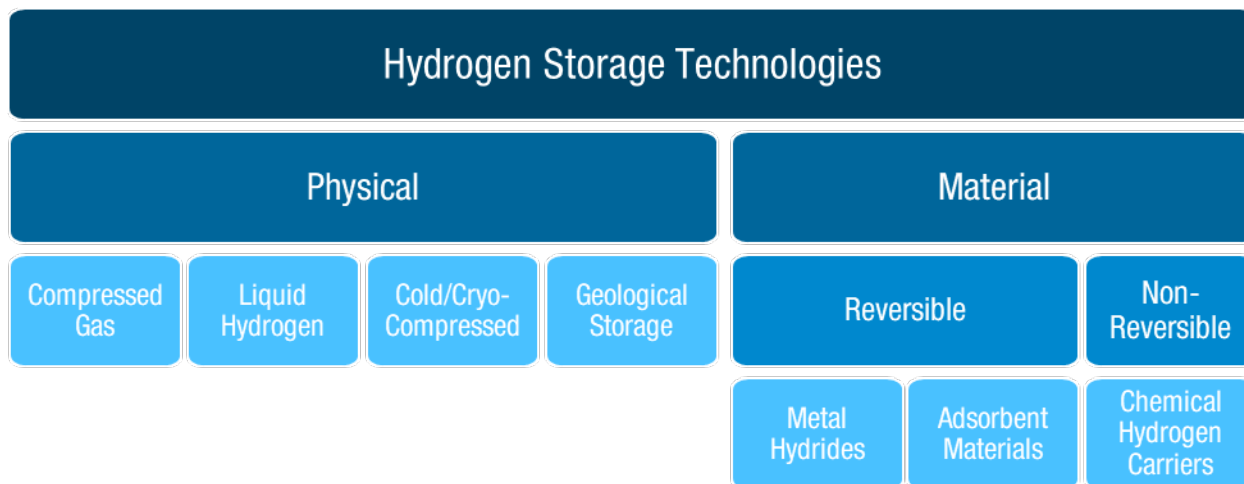
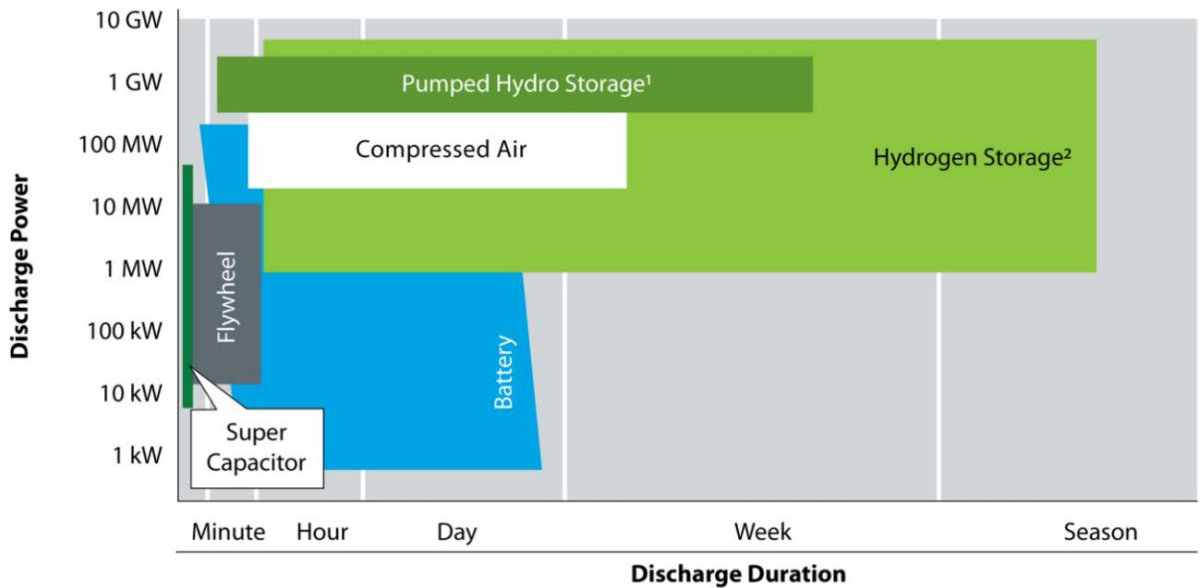

Figure 19. Categories of some important hydrogen storage technologies

Source: EERE (2020b)



¹ Pumped hydro capacity is limited due to geographic constraints. Estimated maximum potential is <1% of U.S. electrical energy demand
² As hydrogen, ammonia, or synthetic natural gas

Figure 20. The optimal discharge power and duration characteristics are plotted qualitatively for several prominent energy storage technologies.

Source: Ruth et al. (2020)

3.5.1 Physical-Based Storage

Hydrogen storage is required at the production site and end-use locations. Analyses have been completed looking at a variety of potential physical-based storage options (Schaber, Mazza, and Hammerschlag 2004). Preliminary analysis estimated the cost of deep-ocean hydrogen gas storage to be ~\$10/kWh, which has the potential for significant cost saving compared to terrestrial compressed tanks, which were estimated to cost ~\$45/kWh (Penev 2013). Liquid hydrogen storage and storage of hydrogen gas in geological formations have potential cost savings over compressed tanks, as shown in Table 2. Analysis by Ahluwalia et al. (2019) presents a variety of land-based storage options with a cost breakdown (\$/kg-H₂) by storage pressure. For marine energy-H₂ integration, electrical energy storage devices such as batteries, supercapacitors, or hydraulic energy storage devices may be required to absorb high transients from the marine energy system depending on the sizing of the hydrogen production system, the layout of the marine energy converter array, and the power electronics linking the two systems together.

Table 2 outlines potential physical-based hydrogen storage options and approximate scale. The most common current hydrogen storage options are steel or composite tank storage. Hydrogen storage tanks are categorized by type. The most common hydrogen tank types are referred to as either Type I, II, III, or IV, which are defined by the materials and methods of construction. Type I tanks are entirely metal and made of steel or aluminum. Type II tanks consist of a metal tank with a filament winding (e.g., carbon fiber) outer wrap. Type III tanks consist of a non-load-bearing metal liner that is wrapped in a composite filament material. Type IV tanks are fully composite tanks with a non-load-bearing polymer liner. Tank selection is dependent on end-use applications and required pressure. In general, Type I and II tanks often are the most economic

choice for stationary storage applications, while Type III and IV tanks are lighter and thus better suited for mobile applications. Type III and IV tanks are not shown in the table. Storage pressure and temperature have a significant impact on the density of the stored hydrogen gas. Decreasing the temperature and/or increasing the pressure has a significant impact on the density of the stored hydrogen. There is also extensive ongoing research on material compatibility of hydrogen with metals and polymers.

Another possible hydrogen storage method is compressed gaseous storage in subterranean salt caverns, the largest of which is operated by Air Liquide and used for long-term backup of a hydrogen production facility (Air Liquide 2017). A variety of subsea storage options have been investigated with other media (air) or for economic viability (Penev 2013; Pimm, Garvey, and de Jong 2014). A paper by Pimm, Garvey, and de Jong (2014) describes the design and deployment of an underwater compressed air energy storage device, which could be redesigned for hydrogen use. The other options listed in Table 2 are primarily for land-based hydrogen storage, including spherical pressure vessels, aquifer storage, pre-stressed concrete, lined rock caverns, and liquid H₂ cryogenic storage (Ahluwalia et al. 2019). When available, approximate cost estimates for each storage technology are included. Many of the storage techniques have been used or demonstrated for natural gas or other media and could be adapted for hydrogen use in the future. It may be possible to adapt some of these terrestrial technologies for deep-sea storage. For integration of marine energy with hydrogen, the first-stage storage out of the electrolyzer and transportation pressures will likely be between 0.7–23 MPa (100–3,300 psi).

Table 2. Potential Hydrogen Storage Systems and Scale

Data collected from FIBA 2021; Penev 2013; Pimm, Garvey, and de Jong 2014.

Technology	Pressure (MPa)	Water Volume (m ³)	Mass Stored (kg-H ₂) ^a	Cost Estimate		Technology Status	Deployment
				(\$/kWh) ^b	(\$/kg-H ₂)		
Steel tank (Type I)	1–100	0.7	32	45	900	Current	Onshore
Pre-stressed concrete	0.7–87.5	22	1,000			Large liquified natural gas systems	Onshore
Wrapped steel tank (Type II, II-S)	0.7–87.5	0.77	35.4			Current	Onshore
Pipeline storage	0.7–10	6,100	50,000	25.8	516	Current/natural gas	Onshore/ underwater
Undersea inflatable	0.6–8	35,705	22,500			Air prototype 29.5 m ^c	Underwater
Undersea concrete lined ^c	0.7–87.5	22	1,000			Future	Underwater
Underground, lined cavern	1–23	40,000	672,000	3.6	72	Future	Onshore
Underground salt cavern	5.5–15.2	566,000	6,000,000	1.75	35	Current	Onshore
Spherical vessels	0.1–1	32,000	27,000			Natural gas	Onshore
Aquifer storage	15–17	4,141,000	54,000,000			Natural gas	Onshore
Cryogenic storage	2	3,400	230,000			Current	Onshore

^a Kilogram of hydrogen calculated from the highest pressure and volume listed.

^b \$/kWh assumes a hydrogen energy value of 20 kWh/kg (Penev 2013; EERE 2016).

^c Assumes same pressure and volume capabilities of above-water pre-stressed concrete construction.

3.5.2 Material-Based Storage

Material-based storage is the storage of hydrogen in certain material or chemical compounds (DOE 2020). Metal hydrides and adsorbents are considered reversible because the storage and release of hydrogen can be controlled by the temperature or pressure (DOE 2020). There is extensive ongoing research into improving and developing metal hydride and adsorbent storage methods. Chemical hydrogen carriers are considered non-reversible because the thermal or catalytic processes required to form or break apart the carriers come with significant round-trip energy losses (DOE 2020). The utilization of chemical hydrogen carriers can improve volumetric energy density, as shown in Figure 21. Additionally, these carriers do not need to be stored at very low temperature or pressure to maintain their volumetric energy density, allowing for easier transport and storage (Dias et al. 2020; DOE 2020). Additional research is needed to move material-based storage technologies to commercial maturity.

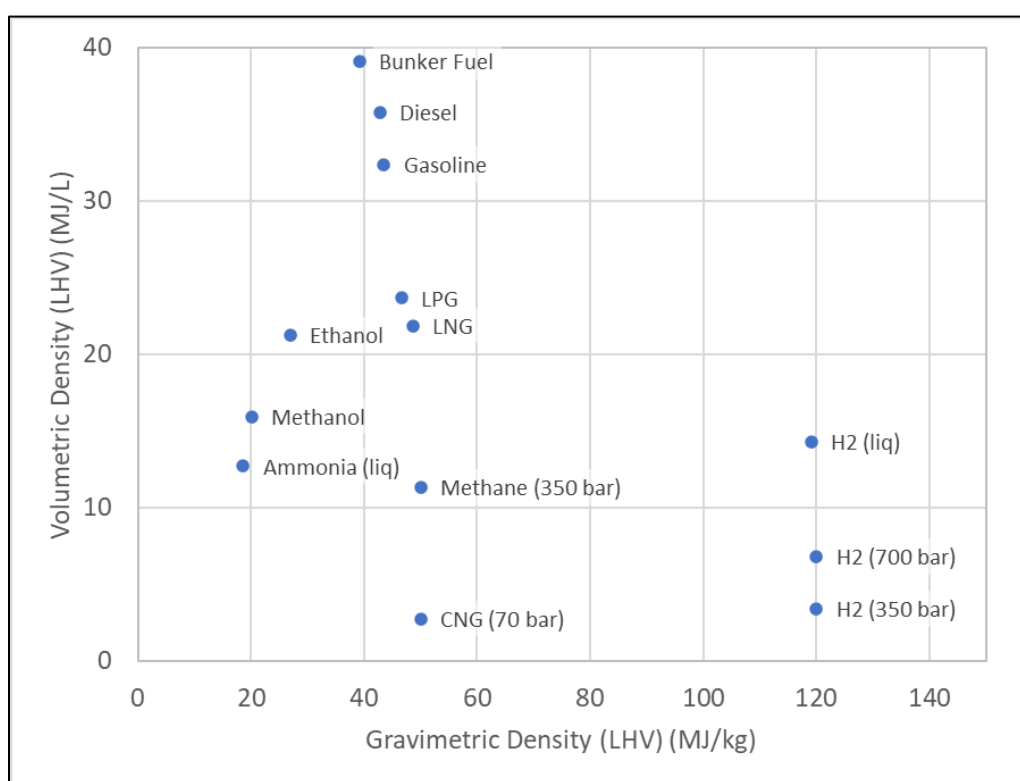

Figure 21. Comparison of gravimetric density and volumetric density for several fuels based on lower heating values.

Data from Wang 2017; Lemmon et al. 2018

For example, ammonia has been studied as a carbon-free fuel candidate to store the electricity from marine energy devices through a one-step electrochemical reaction (nitrogen reduction reaction) between water and air at ambient conditions (Bao et al. 2017; Deng, Iñiguez, and Liu 2018). Compared to hydrogen, ammonia is easier to liquefy and transport, and it is more energy-efficient and cost-efficient to store and deliver liquid ammonia than compressed and/or cryogenic hydrogen (Lan and Tao 2014). The volumetric energy density of liquid ammonia is higher than that of compressed hydrogen, as shown in Figure 21. This advantage may lead to opportunities for renewable ammonia from marine energy to be used at sea where space is limited. Ammonia is known as a good hydrogen carrier, and each ammonia molecule contains about 48% more

hydrogen by volume than liquefied hydrogen (Hu, Xing, and Feng 2020). It is also possible to achieve a high conversion (98%) of ammonia to hydrogen at 425°C with a catalyst (Klerke et al. 2008; Lan, Irvine, and Tao 2012). One of the key challenges for making ammonia from renewable electricity is to increase the Faraday efficiency of the electrocatalyst to be higher than 10% so that this technology can be more viable (Liu et al. 2020; Singh et al. 2017). Some progress has been made on using porous carbon as the platform for the nitrogen selective electrocatalyst. Both organic polymers such as polyimide and high-surface-area hybrid material metal-organic frameworks were used as the precursors to obtain porous carbon with high surface area and interconnected porous structure. Metal and metal salt nanoparticles (Cu, Co, MoFe, Ni(NO₃)₂), boron doping, and nitrogen doping have been used to modify the carbon surface and to enhance the nitrogen reduction reaction (Chen et al. 2020; Lin et al. 2019; Mukherjee et al. 2018; Yin et al. 2019; Yu et al. 2018; Zhang et al. 2019). Currently, this nitrogen reduction through electrochemical reaction technology is still in the lab stage. Like other material-based hydrogen storage approaches, additional research is needed to move material-based storage technologies to commercial maturity.

4 Potential Applications of Marine Energy-H₂ Systems in the Blue Economy

This section discusses the viability of marine energy-H₂ systems for powering different applications in the blue economy, which is broadly understood to encompass “the interplay between economic, social, and ecological sustainability of the ocean” (LiVecchi et al. 2019). The foremost consideration for identifying potential opportunities is to match the location and geography of these maritime applications with the availability of marine energy resources in those regions. The bathymetric specifications would also inform the H₂ storage options. Additionally, the value that hydrogen systems coupled with marine energy resources can provide to a particular application is assessed. This requires a qualitative and quantitative understanding of the energy and power requirements of the considered end uses. For instance, some end uses will be better able to adapt to the variable energy production that is innate to some marine energy resources, while others will require a more stable energy source or a large energy storage capacity. The ranges of power and storage requirements for different blue economy applications are shown in Figure 22. It is important to note that different applications may have considerably different scales and relationships between the required power and energy storage capacities. Therefore, it would be important to consider these differences when selecting the appropriate marine energy resource and identifying the benefits hydrogen storage could bring compared to other storage options.

Finally, the identified marine energy-H₂ systems are compared against the existing/alternative technologies for powering these applications. While several blue economy opportunities exist, here we present the ones where the location, end uses, and benefits against alternative power sources render implementation of marine energy-H₂ systems particularly viable. Table 3 summarizes the identified blue economy opportunities and the applicability of marine energy-H₂ systems for powering their end uses. These applications are discussed in detail in the following subsections.

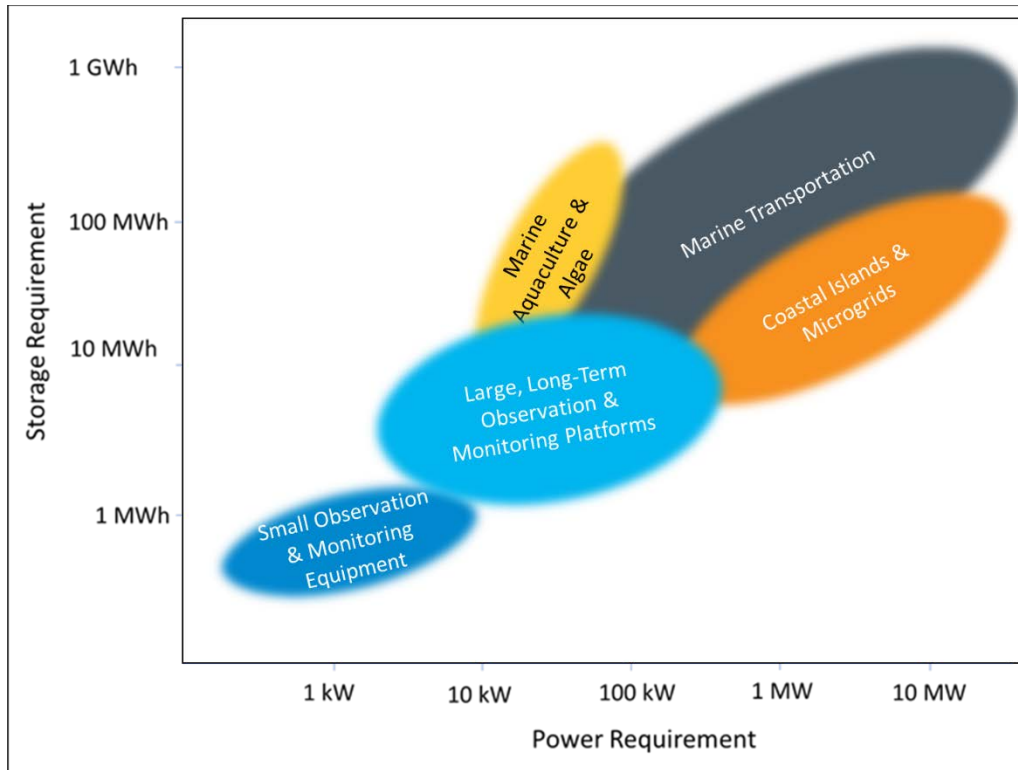

Figure 22. Range of power and storage requirements of the various blue economy applications potentially viable for marine energy-H₂ implementation.

Data from LiVecchi et al. 2019; Brasseur, Tamburri, and Pluedemann 2010; Tetra Tech, Inc. 2007; Guangrong 2017; Brown and Aldridge 2019; Hughes and Gish 2017; Bankston and Baker 1995; Alaska Energy Authority 2015

Table 3. Summary of Exemplar Blue Economy Applications That Could Be Candidates for Marine Energy-H₂ Systems

Application	Energy End Use	Power Requirement	Existing/Alternative Power Options	Marine Energy Resource	Potential Advantages of H ₂ Systems	Geography
Ocean observation and navigation	Sensors and navigation aids May include high-power devices	Coastal buoys: 40–200 W Large platforms: 10–600 kW	Cabled connections and batteries for small coastal buoys Diesel generation and offshore wind and solar for larger platforms	Wave energy for surface-level buoys. Ocean currents for larger remote platforms Hydrothermal vents for seafloor observation Tidal energy in narrow channels near shipping lanes	Almost constant power requirement Long-term missions in remote sites Avoid repeated visits, refueling, and/or cabled power supply	Depends on the site of interest Both nearshore and far offshore Both surface-level and subsurface
Marine transportation	Propulsion and ancillary systems	Depends on range, ship type, efficiency, etc. 50 kWe–20 MWe	Onboard diesel generation	Large OTEC systems	Direct usage in vessels with frequent refueling access Producing fuels for long-haul routes	Both coastal and offshore refueling possible
Unmanned underwater vehicle (UUV) refueling	Refueling UUVs for propulsion, communication, navigation, etc.	Depends on mission requirements and number of UUVs 200–500 W to charge in 4–8 hours 66 kWh to 2.2 MWh per recharge station	Diesel generator sets and offshore wind/solar for refueling stations Onboard batteries for UUVs	Tidal or ocean current turbines Wave energy technologies with low to no surface expression	Long-duration backup at refueling stations for on-demand recharging of UUVs Placement of stations in calmer waters Onboard fuel cells for range extension of UUVs	Depends on the mission site Calmer waters reduce operational complexity of UUVs Refueling station would ideally rest on the seafloor
Offshore marine aquaculture and algae	Safety, navigation, maintenance, circulation pumps, refrigeration loads, etc.	Depends on size, location, type of fish, need for water purification, manned/unmanned operation, etc. 4–715 MWh per year.	Diesel or kerosene generation from onboard generator sets with battery backup Recently, solar + battery systems have been used	Wave energy where cages and enclosures can withstand greater wave activity OTEC and ocean current energy for offshore applications	Mitigate the impacts of wave power variations at short timescales Long-duration storage for asynchronized seasonal energy demand and wave energy availability	Both coastal and offshore locations Usually sited in calmer waters with adequate flow to supply nutrients
Coastal/island microgrids and resiliency	Powering homes, transportation, and other community energy needs Electrical grid black start	Microgrid power systems can be rated from anywhere between 200 kW and 5 MW	Diesel generators Dependent on few bulk deliveries each year	Tidal or ocean current turbines Wave energy	Direct utilization for transportation needs Mitigate the impacts of energy generation variations at short timescales Longer-duration support during blackouts	Coastal locations for short-distance electricity transmission Communities in high-latitude areas

4.1 Ocean Observation and Navigation

Ocean observation and navigation instruments are of particular significance for the maritime economy as they monitor oceanographic conditions and facilitate safe navigation. Oceanographic and meteorological instruments include a wide range of sensing and ambient monitoring equipment that track changes in the marine environment in near real time. Therefore, these instruments are critical for predicting, managing, and adapting to the changing oceanographic conditions. Navigation aids assist maritime traffic by marking areas of danger and zones for safe passage, thereby reducing the risks of collisions, allisions, or groundings. Owing to the paramount importance of these observation and navigation applications, the global market for navigational and survey instruments more than doubled between 2001 and 2011, from \$7.5 billion to \$16 billion (Lee, Turnipseed, and Brun 2012). The increasing deployment of these instruments across hundreds of locations along the U.S. coastline and offshore territories encourages the pursuit of sustainable solutions to meet their power requirements.

The ocean observation and navigation applications can range from small coastal buoys with limited sensing capabilities (requiring only around 40–200 W of power) to large, dedicated platforms featuring high-powered devices (requiring 10–600 kW) deployed for long durations in remote offshore locations (Brasseur, Tamburri, and Pluedemann 2010). Additionally, the required observations span a wide range of physical, chemical, geological, and biological variables in the ocean, seafloor, and overlying atmosphere (Green et al. 2019). Therefore, the observation sites can be located along coastlines, on continental shelves, along the margin of oceanic plates, in remote offshore locations, etc. Both surface-level and subsurface deployments are common, depending on the nature of the measurements to be made. This diverse range of end-use power requirements, mission duration, and geographic conditions means that a particular marine energy resource might not be suitable for all observation and navigation applications. Instead, the choice of marine energy resource should be driven by the location and geography of interest. The mission specifications and corresponding energy end use are of utmost importance for selecting the appropriate marine energy resource and the corresponding size of the H₂ system.

Bathymetric considerations would play a major role in the choice of suitable marine energy resources due to the possible co-location benefits. For instance, wave energy converters would be suitable for powering surface-level observation and monitoring equipment (NOAA 2020). Midwater-column ocean observation equipment generally consist of unmanned underwater vehicles, which are discussed in detail in Section 4.3 (NOAA 2018). On the other hand, powering remote observation sites located at the seafloor using co-located ocean current turbines or hydrothermal vents could substantially reduce seafloor cabling requirements and ensure reliable power supply for long-term deployments.

Currently, nearshore low-power applications (40–200 W), such as small coastal buoys, are typically powered with cabled connections or batteries (LiVecchi et al. 2019). Utilizing marine energy resources for these applications would not only avoid the dependence on the electrical grid but also reduce the costs of installing and maintaining power supply cables. Compared to onboard batteries, hydrogen storage can provide significantly longer-duration backup, reduce recharging and replacement costs, and potentially improve equipment safety by avoiding the hazards associated with thermal runaway of batteries. Among the available marine energy resources, wave power systems might be the most suitable because the available wave generation

locations cover the entire coastlines (Gunn and Stock-Williams 2012), and wave energy converters are typically rated from kilowatts to a few megawatts (Aderinto and Li 2019). While the co-location and power range benefits are noteworthy, it is important to realize that ocean observation and navigation equipment require a constant power supply. The seasonal and diurnal variability associated with wave power might therefore hinder these applications. However, this is where coupling of wave energy with hydrogen systems (comprising electrolyzers, storage, and fuel cells) would be of obvious value. As shown in Figure 23, these hydrogen systems can be coupled with surface wave energy systems to mitigate the impacts of wave power variability and can be used to provide constant power to both surface-level and subsurface applications. The rating of these hydrogen systems depends on the nature and number of observation and navigation instruments being powered by a common wave energy conversion system. Assuming an application where tens of low-power coastal buoys (with an average 100-W requirement) share a common wave energy conversion system, the required H₂ system would be rated at around 1 to 10 kW with up to 5 to 10 kg of H₂ storage capability to provide constant power backup for a whole day.

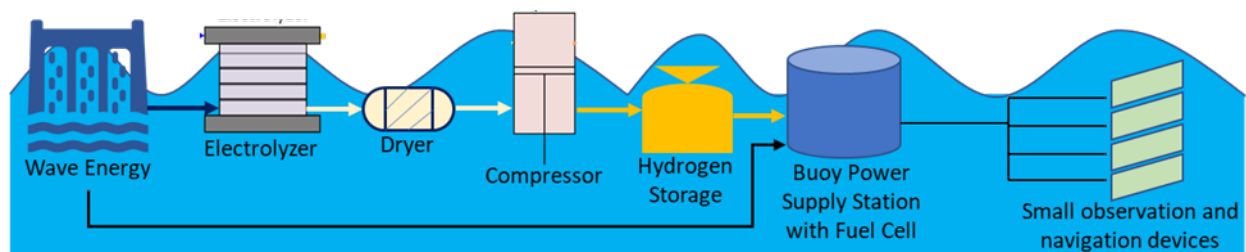

Figure 23. Conceptual framework for powering small coastal observation and navigation devices using wave energy and H₂ systems

High-power oceanic observation platforms deployed for long durations (for studying phenomena that manifest over longer timescales) lie on the other end of the spectrum. These large observation platforms are typically powered by onboard diesel generation or offshore wind and solar energy systems coupled with batteries, depending on the location of interest (LiVecchi et al. 2019). Diesel-powered systems have the disadvantage of needing frequent refueling, which could be impractical for remote observation and navigation sites. Solar photovoltaic (PV) panels might suffer from significant seasonal variations in energy output at high latitudes (Awad and Gül 2018), are restricted by the available surface area, and may need more frequent maintenance and cleaning because of corrosion, biofouling, and bird droppings (Liu et al. 2018). Large offshore wind is generally location-dependent and provides power outputs that are unnecessarily large for supplying ocean observations and navigation needs (LiVecchi et al. 2019).

Hybrid marine energy-H₂ systems can be precisely tailored for the specific energy requirements of observation and navigation equipment and are especially suitable for remote deployments in high-latitude regions. Large oceanic observation platforms can be powered by ocean current turbines as they can exploit the high energy density of ocean currents for fulfilling the high-power needs. The variations in ocean current energy can be smoothed through subsea or onboard H₂ systems that provide constant power to the equipment, as depicted in Figure 24. Additionally, H₂ storage systems can potentially provide longer-duration backup with fewer replacement needs as compared to batteries, making them particularly suitable for longer-term deployments. H₂ storage could also facilitate deployment of higher-rated equipment and faster data transfer rates,

which can improve both the quality and quantity of collected data. The safety benefits of H₂ storage as compared to lithium-ion batteries would be further pronounced for large observation platforms in terms of reducing the costs associated with expensive, sophisticated equipment on board and the need for additional protection installations. Depending on the power needs of the equipment and the variation of ocean currents, H₂ production and storage systems could be sized from 10–600 kW with a storage capacity ranging from a few kilograms up to a few hundred kilograms for providing backup power.

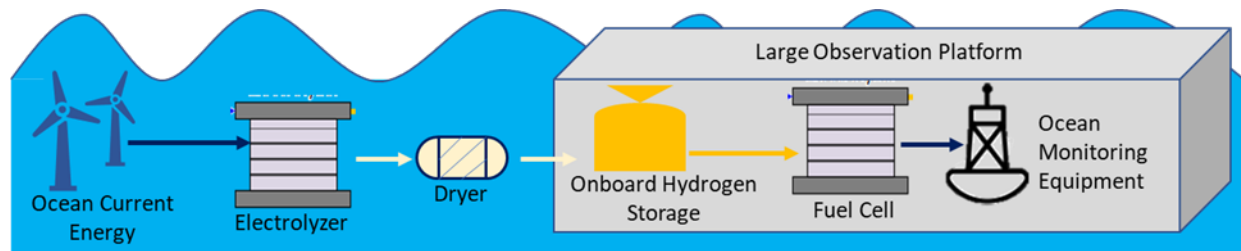

Figure 24. Conceptual framework for powering large ocean observation platforms using ocean current energy and H₂ systems

4.2 Marine Transportation

Shipping accounts for approximately 3.1% of annual global CO₂ emissions and 15% of annual global nitrogen oxide (NO_x) emissions (International Maritime Organization 2016). Consequently, the International Maritime Organization has set requirements for cutting greenhouse gas emissions—including a 2020 global 0.5% sulfur cap affecting up to 70,000 ships—which has created significant pressure for adaptation and innovation. Some strict emissions limits are already in place in specific emission control areas, partially in response to local air and noise pollution, along with evolving global requirements (LiVecchi et al. 2019). To comply with these evolving objectives and requirements, companies are adapting or retrofitting engine systems to run with cleaner-burning fuels, converting to fully electric vessels, or incorporating hydrogen fuel cells. It can be expected that with these increasing global efforts toward decarbonization and reduction of air pollution, marine energy-H₂ systems could power a significant portion of the marine transportation market.

The significant changes in the marine transportation sector present a unique opportunity for marine energy resources to sustainably meet the energy requirements. This is because OTEC systems have high power ratings (ranging from a few megawatts to hundreds of megawatts [National Research Council 2013]) with relatively smaller footprints compared to offshore solar and wind generation, and they are located well offshore, where large oceangoing vessels spend much of their time. Additionally, unlike solar, wind, and other marine energy resources, OTEC energy outputs are highly constant, stable, and predictable (with capacity factors around 0.9), which would be critical if the vessels depended on the site for fuel.

It is important to recognize that the energy generated from OTEC systems (and other marine energy resources) needs to be stored for marine transportation applications. While battery-electric vessels might be suitable for lightweight, short-distance marine transport (e.g., in ferries requiring about 50 kW-e to a few hundred kilowatts), longer-distance, heavy-duty shipping vessels (with power requirements ranging from 1 MW-e to 40 MW) present several opportunities for integrating H₂ systems (Tetra Tech, Inc. 2007; Brown and Aldridge 2019; Guangrong 2017).

H₂ could be directly used in internal combustion engines or fuel cells to power propulsion systems in vessels that are able to refuel regularly. Several pilot projects are underway using hydrogen as a transportation fuel, including for towboats, passenger ships, ferries, and short-haul truck routes (Pratt 2017; Madsen et al. 2020). Indeed, H₂ storage would be suitable for powering longer-range transportation requirements compared to all types of batteries due to the higher energy density of H₂.

For vessels that spend days or weeks at sea such as tankers, super trawlers, or cargo ships, the size of the fuel tanks needed for hydrogen would be prohibitive. For these applications, higher-energy-density fuels derived from hydrogen, such as ammonia and methanol, can be viable clean alternatives to fossil fuels, as depicted in Figure 25. Additionally, H₂ fuel cells can be installed as auxiliary power units to produce onboard electricity in cases where it is not economical to retrofit the full drivetrain on large vessels. In addition to reducing greenhouse gas emissions, replacing fossil fuels with hydrogen and its derivatives would also reduce the impacts of potential spills as both ammonia and methanol are biodegradable, implying that they quickly become so diluted that they no longer carry any danger to wildlife (Bicer and Dincer 2018; Brynolf, Fridell, and Andersson 2014). Several companies are already working on designing efficient ammonia-fueled engines to replace conventional diesel engines for shipping applications (Normani 2020; Scott 2020). Considering that long-distance marine transport vessels require hundreds of thousands of gallons of fuel, OTEC systems coupled with H₂ production, storage, and reactors for producing the derived fuels would need to be sized accordingly to meet the refueling requirements. Several implementation challenges still need to be addressed to harness the energy from OTEC systems in a reliable, cost-effective, and sustainable manner.

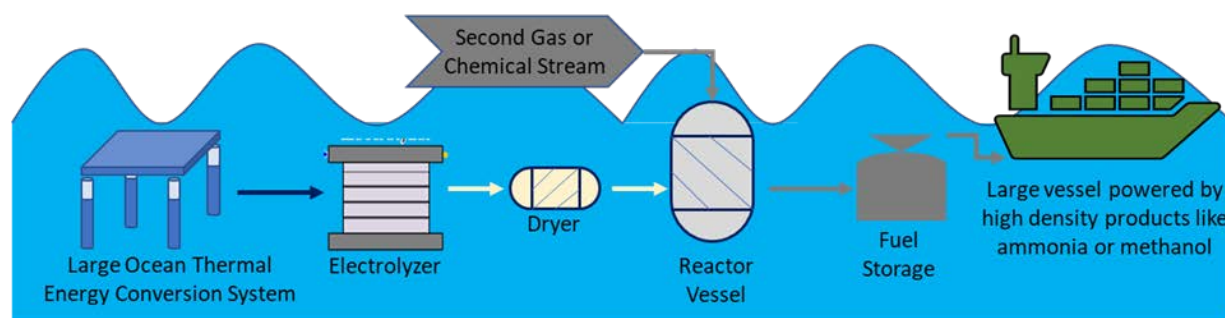

Figure 25. Conceptual framework for powering large oceangoing vessels with high-density products (like ammonia or methanol) derived from H₂ produced from OTEC systems

4.3 Unmanned Underwater Vehicle Refueling

UUVs are vehicles that can operate underwater without a human occupant. These vehicles include both remotely operated underwater vehicles, which are controlled by a remote human operator, and autonomous underwater vehicles, which operate independently of direct human input. UUVs are typically used for observation, surveillance, persistent monitoring, and inspections of subsea infrastructure; therefore, they are very valuable for military and commercial applications (LiVecchi et al. 2019). These vehicles can also be equipped with ocean sensors to provide ocean observations and measurements. Based on the vast range of military, commercial, and scientific research applications of UUVs, their global market is expected to double from \$2.6 billion in 2017 to circa \$5 billion by 2022 (Research and Markets 2017).

The vast range of UUV applications also means that their deployments could be in different geographic and bathymetric conditions. Ideally, the power source should be able to operate over a wide depth range that is estimated to be between 50 and 1,000 m under varying sea conditions (LiVecchi et al. 2019). UUVs typically feature low-power equipment (e.g., propulsion, anchoring systems, sensors, navigation aids, communications, data storage) and usually rely on onboard batteries for power supply. Therefore, these vehicles are limited in their range and duration by the capacity of their batteries. Depending on the vehicle sensor payload, they may also have limited data storage space. These operation constraints mean that UUVs require frequent recovery for recharge and data offload, which generally requires the assistance of a support vessel and crew.

Currently, there are various options for recharging UUVs. Recharging stations powered by diesel generator sets must be surface-based and would require frequent refueling and maintenance, leading to poor stealth characteristics, high costs, and risk of spills. Other offshore renewables, such as solar and wind, are less suitable replacements, as underwater charging requirements would result in extensive cabling from any surface power source and reduce stealth as a result of the surface expression of power generation sites. Placing solar PV panels close to the ocean surface will require frequent cleaning of the panels from salt spray and bird droppings. Wind turbines would have to be surface-based on a platform or bottom-mounted on foundations, making them depth-limited for underwater recharge applications (LiVecchi et al. 2019).

Considering these factors, subsea hydrokinetic resources such as tidal and ocean current turbines and wave energy technologies with little to no viewshed would be particularly suitable for powering UUVs. These marine energy resources can be coupled with underwater docking and refueling stations (currently in demonstration phases [Dhanak and Xiros 2016]), which would preferably be designed to rest on the seafloor and be connected to a cabled observatory for data offloading, as depicted in Figure 26. This would allow several UUVs to use the same charging and data-offloading infrastructure without the need for surfacing. These docking stations would benefit from H₂ storage systems to smooth the variations of ocean current/tidal systems and to recharge the UUVs on demand. The significantly higher energy density of hydrogen storage compared to other energy storage alternatives would allow it to provide longer-duration backup and serve a larger number of UUVs. It is also important to note that operating UUVs in fast-flowing ocean currents may increase operational complexity, but these locations are ideal for marine power extraction. Underwater H₂ storage systems can also avoid the need to co-locate the docking stations and marine energy systems, thereby avoiding the need to operate UUVs in turbulent conditions. Ocean current turbines are also particularly suitable for coupling with H₂ systems, as they are located at the seafloor, making local storage and dispensing of high-pressure hydrogen feasible at low capital costs (Menear 2010).

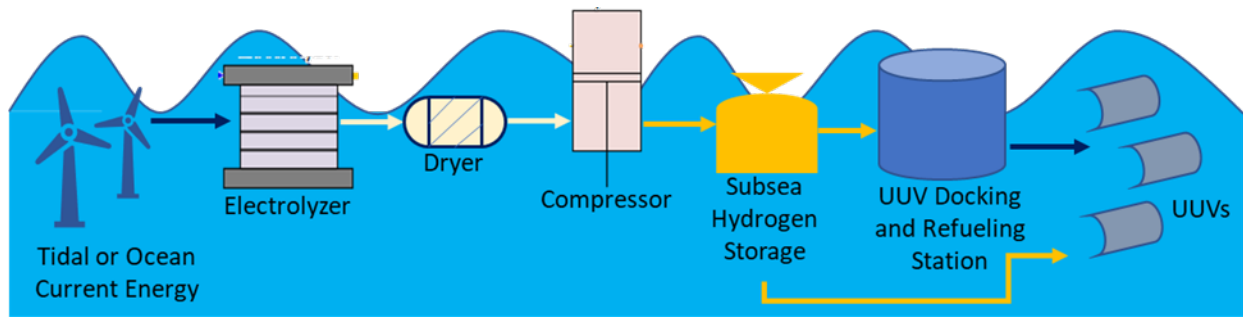

Figure 26. Conceptual framework for powering UUVs using tidal/ocean current energy and H₂ systems. Battery-operated UUVs can be recharged by a central docking and refueling station, while fuel-cell-operated UUVs can be directly fueled by subsea H₂ storage.

Considering that a typical battery-powered UUV requires around 200–500 W to get fully charged in 4–8 hours (Hughes and Gish 2017) and a docking station would serve tens of UUVs, it can be estimated that the docking stations could need circa 100 to 500 kWh, translating to about 2 to 15 kg of H₂ storage, to provide daily energy requirements. Small-scale hydrogen fuel cells can also be used to replace the onboard batteries of UUVs to extend their mission duration, increase data collection capability, and reduce the costs associated with recharge trips and battery replacements. Additionally, UUVs powered with fuel cells would potentially have shorter refueling times than battery-powered UUVs (as shown in Table 4, which provides a comparison for battery-electric vehicles and fuel cell electric vehicles), leading to reduced down/idle times. Small-scale compact fuel cells are already being developed for unmanned aerial vehicles and drones (Plaza 2017) and could also find application in the UUV market.

Table 4. Estimated Minimum Fueling Time for Battery-Electric Vehicles and Fuel Cell Electric Vehicles

Source: Thomas (2009)

Vehicle Range (km)	Energy Required (kWh)	Battery-Electric Vehicles				Fuel Cell Electric Vehicles
		Level 1 ^a Charging Time (h)	Level 2 ^b Charging Time (h)	Level 3 ^c Charging Time (h)	Level 3 ^d Charging Time (h)	Hydrogen Tank Fill Time (h)
241	56	29.2	7.30	0.9	0.40	0.08
322	82	42.7	10.68	1.4	0.55	0.10
483	149	77.6	19.40	2.5	0.99	0.15

^a 120 V, 1.9 kW
^b 240 V, 7.7 kW
^c 480 V, 60 kW
^d 480 V, 150 kW

4.4 Offshore Marine Aquaculture and Algae

Aquaculture is the rearing of aquatic animals or the cultivation of aquatic plants for food. It is one of the most promising sectors of the maritime economy and is the fastest-growing animal food-producing sector on the planet (Nassar et al. 2020). Algae refers to a diverse group of organisms including macroalgae, microalgae, and cyanobacteria (“blue-green algae”) that can be grown at commercial scale at sea to provide biofuels, animal feed, and other coproducts (Barry et al. 2016). The global aquaculture market is estimated to be more than \$55 billion (FAO 2016),

while the market for products derived from algae and seaweed is estimated to be well over \$20 billion (LiVecchi et al. 2019). Recognizing that more than 90% of U.S. seafood is imported, there exists a significant opportunity for offshore and nearshore aquaculture and algae production.

Aquaculture and algae production sites can be located at both coastal and offshore locations, and at surface level or seabed, depending on the species that are farmed. For instance, finfish, including anadromous fish such as salmon, and marine fish, such as halibut, turbot, and black cod, are grown in net pens that are suspended off the seafloor or floating on the surface, while seaweeds for human and animal consumption are typically grown near shore (LiVecchi et al. 2019). However, typically all aquaculture and algae sites are sited in the calmest waters with adequate flow to supply nutrients (Gentry et al. 2017).

For marine aquaculture and algae applications, power is required for standard safety, navigation, and maintenance equipment. Additionally, automatic fish feeders, circulation pumps, refrigeration, and ice production also require significant power. For operations that require manned structures, hotel loads for crew living quarters also need to be powered. The magnitude of the total power and energy requirements depends on several factors including the size, location, need for water purification and recirculation systems, and manned/unmanned operation. Therefore, a wide range of energy requirements—from 4 to 715 MWh per location per year—have been estimated (LiVecchi et al. 2019). Traditionally, these requirements are met using diesel or kerosene generation from onboard generator sets with battery backup. However, concerns over local air and water quality from emissions are strong drivers for transitioning aquaculture from fossil fuel sources to renewables. Recently, solar PV panels with battery storage have been deployed for aquaculture applications (NRG 2018). However, offshore solar panels require frequent maintenance and are constrained by the available surface area and latitudes of operation.

While the need for calmer waters for marine aquaculture and algae may not coincide with the best marine energy resources, there are likely to be many locations where adequate wave resources can generate the amount of energy needed by aquaculture operations, particularly offshore, where heavy-duty cages and enclosures can withstand greater wave activity (LiVecchi et al. 2019). There are several potential synergistic opportunities for co-location of aquaculture and wave energy devices. Co-locating aquaculture and WEC infrastructure could save on installation and capital costs for both systems. Large-scale wave farms may provide shelter in their lee, which would benefit aquaculture operations. Additionally, when competing with solar energy, wave energy can offer aquaculture power around the clock and in high latitudes in winter.

H₂ systems can provide both short- and long-duration support to wave energy generation for aquaculture applications. At the shorter timescales, H₂ storage can mitigate the impacts of wave power variations, thereby providing smooth, constant power for the various end uses. Higher-density fuels derived from H₂ (e.g., ammonia and methanol) can be used as sustainable alternatives to traditional diesel or kerosene generation. Replacing fossil fuels with hydrogen and its derivatives would also reduce the potential impacts of spills on the fish and algae populations, as both ammonia and methanol are biodegradable (Bicer and Dincer 2018; Brynolf, Fridell, and Andersson 2014).

The opportunity for H₂ storage for marine aquaculture applications at longer timescales is even more promising. Fish farms typically go through a 2- to 3-year energy demand cycle, which correlates with the amount of biomass present and the stage in the production cycle. These energy demand cycles are not necessarily synchronized with the seasonal availability of marine energy resources (LiVecchi et al. 2019). Therefore, utilization of H₂ for long-duration seasonal energy storage becomes particularly appealing for powering aquaculture using marine energy resources. H₂ storage would also avoid the safety risks attributed to battery storage, which would be particularly important for manned aquaculture facilities. A conceptual framework for powering aquaculture and algae production sites using wave energy and H₂ systems is shown in Figure 27. While the size of these H₂ systems would depend on the magnitude of the difference between seasonal peaks of aquaculture energy needs and the available marine energy, it is estimated that these systems could require a few thousand kilograms of H₂ storage to meet the energy needs in the worst-case scenarios.

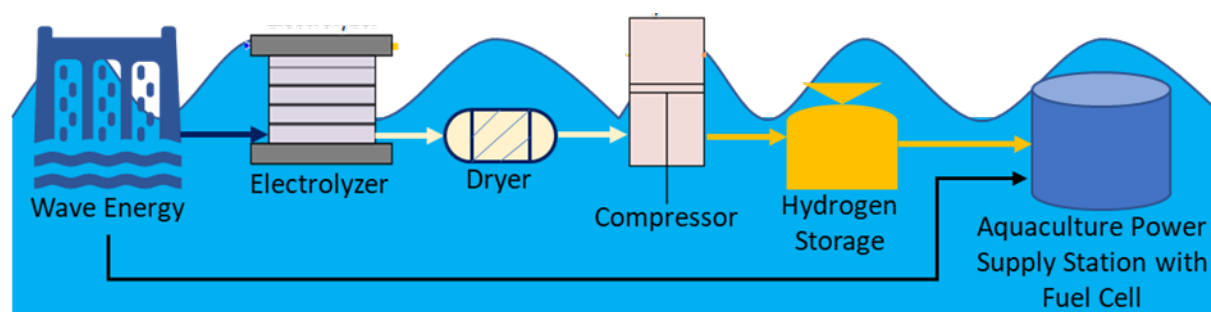

Figure 27. Conceptual framework for powering aquaculture and algae production sites using wave energy and H₂ systems

4.5 Coastal/Island Microgrids and Resiliency

The United States has hundreds of isolated and remote communities, primarily in Alaska and island territories, that have microgrid power systems from 200 kW to 5 MW (Alaska Energy Authority 2015). Currently, most of these communities are dependent on diesel generators for some or all of their power requirements. Due to the strong dependence on the price of oil and supply chain logistics, the energy cost of these communities is noticeably higher than the national average (Alaska Energy Authority 2015). Additionally, transporting diesel is difficult and expensive, can have potentially severe spillage consequences, and, in many cases, requires extensive storage capacity. These remote communities rely on a few bulk fuel deliveries each year and are therefore particularly susceptible to supply chain disruptions and fuel price volatility. The situation is exacerbated during system power outages caused by extreme weather events. For outages requiring a black start, absence of resilient and reliable generating assets could mean that these communities may remain without power for extended durations until the supply chain disruptions are resolved. Therefore, development of local energy resources is of primary importance to provide stable, on-demand power to the critical infrastructure in these isolated communities and to resolve the security of supply and resiliency challenges.

Considering that most of these isolated communities have access to harvestable marine energy resources—wave energy or tidal current for coastal and island communities and river current for inland locations (Kilcher and Thresher 2016; Alaska Energy Authority 2015)—the

aforementioned challenges facing these communities can be mitigated through the deployment of marine energy systems. Marine energy as a part of a mix of generation resources (together with solar and wind) creates a more reliable system because a single point of failure or change in resource has less impact on the system. The choice of generation mix for these communities would depend on their geographical characteristics. For midlatitude and tropical communities, marine resources could complement solar PV generation by providing power around the clock with limited storage requirement. For high-latitude locations, marine energy resources could provide some or all of the power requirements, particularly if they are cost-competitive with wind generators, which typically have high installation and maintenance costs in remote locations.

The need for H₂ systems to complement marine energy resources would depend on the available marine resources in the region. A conceptual framework for powering remote coastal/island communities using local marine energy resources coupled with H₂ systems is depicted in Figure 28. Communities with access to tidal current resources would benefit from the predictability and almost year-round availability of tidal energy. However, tidal currents have semidiurnal or diurnal cycles, which makes them suitable for coupling with short-duration storage. Therefore, H₂ storage systems would compete with batteries for providing stable power to these communities. On the other hand, communities with ocean and river current resources would have the benefit of near-continuous power generation, but these resources can be seasonal and unpredictable. Therefore, H₂ systems would be appropriate for providing long-duration storage in these regions. H₂ storage systems would also be more suitable than batteries for resiliency applications, as they can provide longer-duration backup during events with extended power outages.

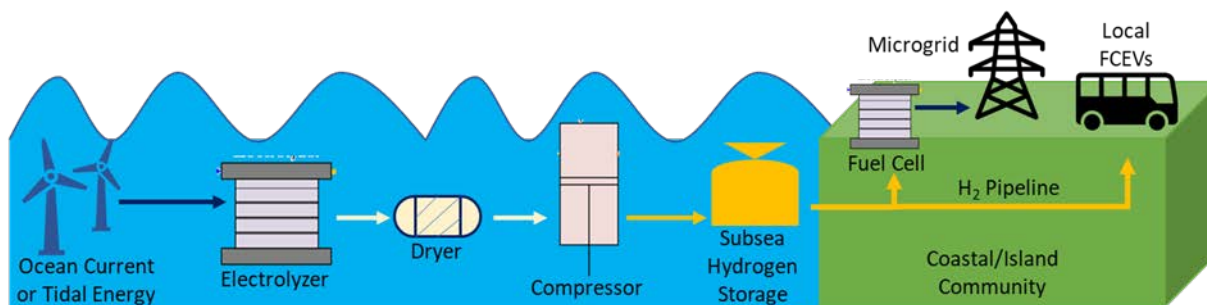

Figure 28. Conceptual framework for powering remote coastal/island communities using local marine energy resources coupled with H₂ systems

Powering remote isolated communities with local renewable resources coupled with H₂ systems is already being demonstrated at scale by the European Marine Energy Center, which is producing H₂ as a means to store unused renewable energy produced from tidal and wind energy in the outer Orkney islands, off the northeast coast of Scotland (EMEC 2017). These systems use 500- to 1,000-kW solid oxide electrolyzers, which can produce approximately 200 to 400 kg of H₂ per day. The produced H₂ is transported to the main Orkney Island for use in the intra-island ferry system, for land transport, and for producing electricity back through fuel cells. Therefore, it can be expected that marine energy-H₂ systems of this type could soon become practically viable for island communities as well as remote locations where the cost of power is high.

4.6 Powering Multiple Applications

While the previous sections described how marine energy-H₂ systems can power various individual blue economy applications, the marine energy-H₂ energy vector lends itself particularly well for powering several different applications in one deployment. This is primarily due to the co-location benefits and opportunities to reduce deployment costs for larger systems in line with economies of scale. This section discusses some of these potential co-powering opportunities.

Coastal and offshore communities can utilize marine energy resources, such as wave and tidal energy, in conjunction with the long-duration storage potential of H₂ to power various applications in addition to the local grid. These can include utilization of H₂ for land transportation and for short-haul marine transportation, such as local ferries and small boats. A demonstration of powering multiple applications is underway in the Orkney islands (EMEC 2017). Additionally, marine energy-H₂ systems present the opportunity to facilitate nearshore aquaculture and coastal tourism for offshore communities, thereby increasing economic activity and creating new jobs.

The use of maritime aircraft is steadily growing for commercial purposes, emergency management, military operations, and environmental monitoring (LiVecchi et al. 2019). Sites for refueling seagoing vessels through marine energy-H₂ systems can also be used by maritime aircraft for landing and refueling. This would be particularly suitable for vertical takeoff and landing aircrafts, which can share the same platform with other forms of marine transportation. These vertical takeoff and landing aircrafts can be powered with H₂ fuel cells (Bolam, Vagapov, and Anuchin 2020; Garrett-Glaser 2020) and can cater to a wide array of applications, including short-transport air taxis, delivery of shipments to maritime industries, and various military operations.

The rapidly increasing energy demand for data centers has given rise to concerns about the ability of the energy industry to reliably power data centers while limiting the growing carbon footprint. Consequently, the data center sector is rapidly expanding and evolving, with major players, such as Microsoft, already demonstrating benefits of subsea data center deployments, which can be powered with abundant renewable resources and have significantly lower cooling requirements (Roach 2020). The reliability and sustainability benefits of marine energy-H₂ systems make them ideal candidates for powering sea-based data centers. The opportunity for data centers to share the same energy source with other maritime applications can further reduce installation, operation, and maintenance costs. For instance, considering that subsea data centers and UUVs both require particularly calm waters and can share data transmission and communication infrastructure, tidal/ocean current energy and H₂ systems can be promising candidates to power co-located data centers and UUV refueling stations.

Excess energy stored in marine energy-H₂ systems designed to power a particular blue economy application, such as coastal aquaculture, can also be used to power ocean cleanup and marine conservation activities. Ocean pollution resulting from plastic waste (Jambeck et al. 2015), oil spillage, and other contaminants is of growing concern to many environmental organizations. Marine energy-H₂ systems present a sustainable option to power operations for collecting plastic waste and removing surface slicks of spilled petroleum and other contaminants. Marine energy-H₂ systems can also power restoration of coral reefs, which are being threatened around the

world (LiVecchi et al. 2019). Rising ocean temperatures result in more mass coral bleaching events and infectious disease outbreaks, which, coupled with the rising acidity of the oceans, threatens reefs by making it harder for coral to build their skeletons (NOAA 2020). Several projects are currently underway studying the use of electricity from marine energy resources to repair these reefs. For example, Zyba has developed an ultra-lightweight wave energy converter to grow artificial coral reefs from minerals in the water through a process known as Biorock, which involves electrolysis of seawater to produce limestone. These techniques are currently being used for reef restoration in various locations, including the Great Barrier Reef and Bali (Klein 2018; Baragona 2016).

4.7 Discussion

The analysis presented above highlights the potential of marine energy-H₂ systems for powering various marine economy applications. While the viability of these hybrid systems is significantly dependent on the nature of the applications, some general applicability factors can be identified.

Compared to generation from fossil fuels, marine energy resources would not only reduce harmful emissions but also improve security of energy supply through reliance on sustainable local resources. Therefore, they can become financially viable under different economic constraints. Geographic and bathymetric factors would play a vital role in the choice of marine energy resources over other renewable energy sources. For instance, the ubiquitous supply of wave energy renders it particularly suitable for coastal and nearshore applications. Additionally, marine energy resources would be suitable for high-latitude applications where solar PV would suffer from significant seasonal variations in energy output. Compared to solar PV, marine energy resources would also be less restricted by the available surface area and may become cost-competitive in the long run considering the need for more frequent maintenance, cleaning, and replacement of PV panels because of corrosion, biofouling, and bird droppings. Compared to offshore wind farms, marine energy resources would be more lucrative for applications with smaller power and energy requirements (such as ocean observation and monitoring) and where low to no surface expression is of prime importance (such as UUV recharging and docking stations). Finally, marine energy resources can also complement other energy sources where applicable—for instance, to reduce the effects of wind and solar energy uncertainty using the high predictability of tidal currents (Roy et al. 2018; Anwar, Moursi, and Xiao 2017).

Coupling marine energy systems with H₂ storage instead of other alternatives (particularly battery storage) would primarily be based on the higher energy density, longer lifetimes, and better safety performance of H₂ storage (Pellow et al. 2015; Thomas 2009). The higher energy density of H₂ storage would allow powering longer-duration missions of UUVs and observation equipment, enable deployment of higher-rated and more precise sensors, and facilitate larger data storage capacity and faster transfer rates. This could radically change the maritime observation and monitoring landscape by providing access to unprecedented quality and quantity of data. Additionally, the higher energy storage capability would be valuable for enhancing the resiliency of off-grid coastal communities. These benefits, coupled with the higher recharging duration and replacement requirements of batteries, would render H₂ storage financially competitive in the long run for these applications.

H₂ storage systems also introduce significant safety benefits compared to other storage alternatives for blue economy applications. Battery storage systems (particularly lithium-ion) are

susceptible to thermal runaway, which can have potentially serious consequences and add to the total costs in terms of equipment replacement, additional safety requirements, and/or insurance costs. H₂ storage can significantly improve operational safety, thereby reducing insurance and safety equipment costs, especially for applications with manned facilities and/or expensive equipment such as long-term deployments of remote observation and monitoring equipment. Additionally, spillage of fossil fuels, such as crude oil, diesel, and kerosene, can cause severe damage to the marine ecosystem and can lead to significant financial and social problems. Being biodegradable, fuels derived from H₂ (e.g., ammonia and methanol) would have considerably low spillage consequences (Bicer and Dincer 2018; Brynolf, Fridell, and Andersson 2014), thereby making them particularly suitable for replacing fossil fuels in marine transportation and aquaculture applications.

In conclusion, marine energy-H₂ systems can quickly become viable for the aforementioned applications in the presence of the factors highlighted above. Assuming that the trends of declining investment costs and increasing technology readiness levels continue in the future, the share of marine energy-H₂ systems could potentially expand into other maritime opportunities (such as corporate renewable generation and data centers) with less stringent applicability requirements.

5 Previous Investigations of Marine Energy to Hydrogen Applications

Few active or completed marine-energy-to-hydrogen projects were identified in the review of openly published literature, and no projects were found that are integrated with offshore end uses for the produced hydrogen. There are, however, many reports and lab-scale experiments that have investigated marine energy-H₂ systems from energy capture to end use. In this section, we review both demonstration projects and paper studies to understand how completely the challenges and opportunities in this space have been characterized to date. Throughout this section, we use the rough breakdown of systems illustrated in Figure 29. Although this grouping is imperfect, it is intended to allow us to visualize how systems have been studied in the past.

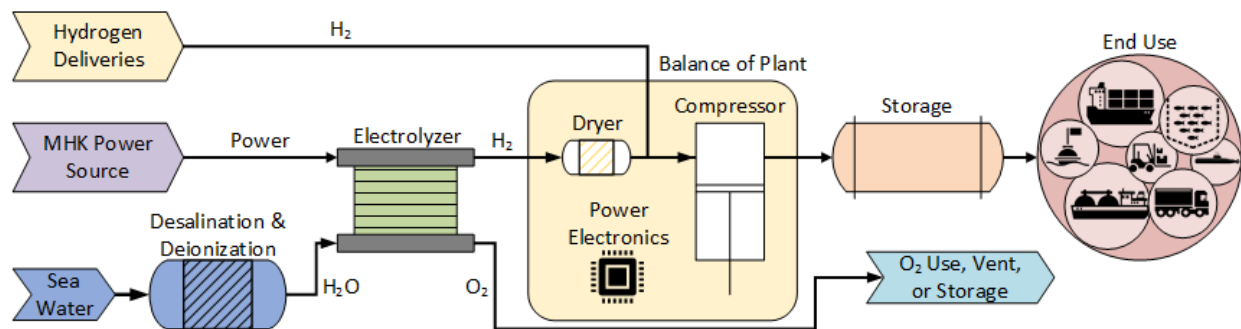

Figure 29. Major subsystems of a marine energy-H₂ project including end uses

5.1 Marine Hydrogen Demonstration Projects

One of the most robust ways to determine the feasibility of a given marine energy-H₂ system is to build and operate an exemplar system. As both the marine energy capture systems and the hydrogen end uses are still nascent industries, there are very few of these demonstration projects

that have been successfully funded. Table 5 summarizes the publicly available demonstration projects that are using hydrogen power in marine applications, and Table 6 summarizes the publicly available information about projects using offshore energy resources to produce hydrogen via electrolysis. In these tables, the details of each system that are publicly available are included and highlighted with color to illustrate which subsystems are typically included in these studies. There are some instances where it is almost certain that a subsystem was included in the research project, but no details were found in the publicly available literature. In those cases, the field for that subsystem was left blank.

These two tables were separated because none of these projects span the full breadth from marine energy resource to marine application of hydrogen. Typically, systems that have been deployed to generate hydrogen using marine energy have used that hydrogen for research or other onshore uses, and systems using hydrogen for offshore uses have gotten that hydrogen via deliveries from traditional sources. While there are some early-stage marine-energy-to-hydrogen technologies (e.g., the WaveRoller green hydrogen system⁴), the closest other examples to a comprehensive marine-energy-to-hydrogen system are the example applications of offshore wind to generate hydrogen for use at ports, and they were included in this analysis because they could serve as useful starting points to understand the unique challenges presented by generating and using hydrogen in marine environments. There has been significant recent global progress in the development and deployment of offshore wind projects generating hydrogen (e.g., Stori [2021] and Table 6), which is expected to generate valuable data and information relevant to the marine-energy-to-hydrogen approaches.

⁴ <https://aw-energy.com/hydrogen/#solution>

Table 5. Publicly Available Information About Projects Using Hydrogen To Power Marine Applications

Subsystems that are not highlighted are not necessarily absent from the project, but they are not discussed in the literature that was reviewed.

Project Name	Location	Status	Scale	Energy Resource	Electrolysis	O ₂ Use	BOP	Storage	End Use
DeepC	Germany							Compressed hydrogen storage (CHS) tanks	Autonomous underwater vehicle main power with onboard O ₂ storage
e5 Tug	Japan	Development	3 MW				Battery, ship-to-shore power		Main propulsion—tugboat
ELEKTRA	Germany								River barge pusher boat
Energy Observer	n/a (mobile)	Active					Fuel cell, batteries	CHS tanks	Maritime range extender
FLAGSHIPS	Lyon, France and Stavanger, Norway	Construction	1 MW	Hydro				CHS tanks	River push-boat and ferry
H2PORTS	Valencia, Spain	Funded							Reach stacker and yard tractor
HFC MARINE	South Funen Archipelago, Denmark								Hybrid battery/fuel cell vessel propulsion
HydroTug	Antwerp, Belgium	Commissioned	4 MW						Diesel dual-fuel engine for tugboat
HYSEAS III	Scotland								Main power for ferry
MARANDA	Arctic	Development	165 kW						Hybrid powertrain system for Arctic research vessel
Nemo H2								CHS tanks	Main propulsion for passenger ship

Project Name	Location	Status	Scale	Energy Resource	Electrolysis	O ₂ Use	BOP	Storage	End Use
ShipFC		Planned (2023)	2 MW						Retrofit offshore vessel with solid oxide fuel cell using ammonia
SHIPPINGLAB	Hvide Sande Port, Denmark	Design	3 MW	Wind	Onshore				Main power for dredger
SPERA Hydrogen	Brunei and Japan	Proof of concept						Shipping methyl-cyclohexane vessels	Onshore applications
TESI Subsea Supercharger	Newport, Rhode Island	Prototype	2.35 MW			H ₂ O ₂ to oxygen generator		CHS tanks	Subsea UUV charging
THRUST Watertaxi	Rotterdam, Netherlands	Planned (2021)	30 kW					Onboard CHS	City water taxi
Wartsila Ship Ammonia Engine	Stord, Norway	Construction						Ammonia	Combustion engine
Water-Go-Round	San Francisco, California	Construction	600 kW					Onboard CHS	PEM fuel cell in passenger ferry
Zemships - Alsterwasser							Onshore ionic liquid piston compressor	CHS tanks	Main propulsion for passenger ship
Zero-V		Concept	1.8 MW					Onboard liquid hydrogen	Primary power coastal research vessel PEM fuel cell
ZEUS – Zero Emission Ultimate Ship	Italy							Metal hydride cylinders	Battery extender for marine vessel

Table 6. Publicly Available Information About Projects Using Offshore Energy Resources To Produce Hydrogen via Electrolysis

Project Name	Location	Status	Scale	Energy Resource	Water Purification	Electrolysis	O ₂ Use	BOP	Storage	End Use
Blue Danube	East Europe	Concept		Offshore wind					River barges of onboard liquid organic hydrogen carriers	Onshore applications
Dolphyn Project	UK			Offshore wind/solar	Desalination on board	PEM	Vented		Pipeline to onshore CHS	Onshore applications
NorthH2	Netherlands			Offshore wind		Onshore				Onshore applications
PosHYdon	Netherlands			Wind	Reverse osmosis, Desalination on board	PEM	Vented		Blended into existing pipeline	Onshore applications
sHYp B.V.	Netherlands	Concept		Offshore wind	None	DSE				Maritime fuel
Surf 'n' Turf	Orkney, UK	Active	500 kW	Tidal, wind		PEM on shore		Compressors (on shore)	CHS tanks	Onshore
Symphony	Concept	Concept		Wave					Onboard CHS	Onshore applications
THyPSO	Concept	Concept		Tidal					Onboard CHS, offtake vessel	Onshore applications

5.2 Paper Studies, Laboratory-Scale Experiments, and Patents

Despite the lack of offshore marine energy-H₂ demonstration projects, there have been a great number of patents, reports, and laboratory-scale experiments that have investigated this subject. A survey of these is laid out in Table 7 with the same color-coded breakdown of different subsystems used in Table 5 and Table 6.

Although many of the published studies attempt to evaluate comprehensive marine energy-H₂ systems, there is always necessarily a level of simplification and assumption that occurs. Authors generally address this by focusing analysis on certain aspects while making broad assumptions about a subsystem or end use. These constraints can make it difficult to assess the validity of the conclusions that are reached in paper studies, especially when they are related to markets and technologies that are nonexistent or very nascent.

There also exists a large corpus of patents related to capturing marine energy resources and using that energy to generate hydrogen and oxygen. In many of these patent documents, the authors note that the production of oxygen via water electrolysis is quite valuable in subsea environments where oxygen is not freely available. We have included a representative sampling of the breadth of patents in Table 7.

Table 7. Paper Studies Focused on Marine and Hydrokinetic Energy to Hydrogen Feasibility and Application

C – conceptual, E – economic, N – environmental, A – analytical/numerical, D – design/patent, X – experimental, P – practical/commercial

Paper	Energy Resource	Water Purification	Electrolysis	O ₂ Use	BOP	Storage	End Use
Ahmadi, Dincer, and Rosen 2013	A - OTEC		A - PEM	A - cooled, vented			
Anderson 1975	C - OTEC					C - Methanol	
Avery, Richards, and Dugger 1985	E - OTEC	E - Generic	E - Generic	E - Liquification	E – Plant-ship	E – liquid hydrogen	E - Methanol, ammonia production
Babarit et al. 2018	E - Far offshore wind						E - Methanol production
Barakat et al. 2019	A - Marine current		A - PEM		A - Power Electronics, Control Strategy	A - CHS	A - Fuel cell
Bicer and Dincer 2018	N - Wind, Hydro						N - H ₂ or NH ₃ for shipping
Blanco-Fernández and Pérez-Arribas 2017	C - Wave, current		C - Generic			C - Generic	C - Shipping fuel
Buhagiar and Sant 2017	A - Wind					A - Subsea inflatable air	
Bunn, Yokochi, and von Jouanne 2014			X - DSE for CI				X - Biofouling marine and hydrokinetic energy PTO devices
Burtch 2006	D - Wind, Wave				D - Wave motion water pump		

Paper	Energy Resource	Water Purification	Electrolysis	O ₂ Use	BOP	Storage	End Use
Chevalier 2016	D – Tidal, wind, wave, solar	D – Reverse osmosis	D – DSE	D – Compressed	D – Floating platform	D - Compressed	D – Fuel cell for power smoothing
Colucci et al. 2015	X - Wave		X - DSE				X - Buoy
Curto and Trapanese 2017	C - Wave		C - DSE				
d'Amore-Domenech and Leo 2019			A - DSE, PEM, SOEC			A - CHS	
de-Troya et al. 2016						C - CHS	C - Shipping fuel
Dugger and Francis 1977	D - OTEC	D – Reverse osmosis			D - Plant ship	D - CHS	D - Ammonia production
Dysarsz 2016	D – Wind and tidal current		D – Generic				
Franzitta et al. 2016	A - Wave and wind						A - Onshore transit vehicles
Gilloteaux and Babarit 2017	N - Sail + water turbine						
Kazim 2005	A - OTEC		A - PEM				
Khosravi et al. 2019	A - OTEC, solar		A - PEM		A - Power electronics, fuel cell for backup power	A - CHS	A - Island grid
Kim and Park 2010	D - Sail + water turbine				D - Ship design		D - Methanol production, carbon capture

Paper	Energy Resource	Water Purification	Electrolysis	O ₂ Use	BOP	Storage	End Use
Kris and Graham 2016	D – Wave + tidal current		D – PEM, alkaline			D – CHS underwater	D – Alternative fuels
Kumano 2018	D – Ocean current		D - DSE		D – Offshore liquefaction	D – liquid hydrogen	D – Onshore activities
Lata-García et al. 2018	A - River current + solar				A - Power electronics, battery, fuel cell	A - CHS	A - Electricity for a local grid
Leanna et al. 2019				P - H ₂ O ₂ as O ₂ source		P - CHS	P - UUV charging via fuel cell
Leonard 2017	D – Ocean current		D – Generic	D – Compressed		D - CHS	
Teng and Chen 2020	D – Tidal current	D – Generic	D – Generic		D – Power electronics	D - CHS	D – Ship fuel
Meier 2014	E - Wind	E – Reverse osmosis and distillation	E - SOEC, PEM		E - Compression		E - Pipeline
Menear 2010	D - Ocean current					D - CHS	
Miller 2016	D – OTEC					D – Ammonia	D – Onshore activities
Noia and Schaffner 2018	D – Wave	D – Generic	D – Generic		D – Floating platform	D – CHS	
Ouchi and Henzie 2017	N - Sail + water turbine		N - Generic			N - Liquid methyl-cyclohexane	
Papadias et al. 2019							E - Vessel power
Pitts 1989	D - Ocean current					D - CHS	

Paper	Energy Resource	Water Purification	Electrolysis	O ₂ Use	BOP	Storage	End Use
Zhiqing et al. 2020	D – OTEC + solar thermal		D – PEM, DSE	D – Compressed	D – Molten salt thermal storage	D – CHS	
Raut and Goudarzi 2018	A - Wave		A - PEM				A - Onshore uses
Raut and Goudarzi 2017	N - Wave		N - PEM, alkaline, SOEC			N – liquid hydrogen	
Salter 1974	A - Wave		C - Generic				
Serna and Tadeo 2014	A - Wave	A – 2-stage reverse osmosis	A - PEM		A - Compressor, batteries		
Serna et al. 2017	A - Wave + wind		A - Alkaline		A - Control software		
Temeev, Belokopytov, and Temeev 2006	C - Wave		C - DSE			C - CHS, metal hydrides	
Thorsen 2014	D – Wave, wind, solar, current	D – Generic	D – Generic		D – Platform, hydrogen purification	D – CHS	D – Alternative fuel
Trapanese 2019	X - Wave		X - DSE				
Troy and Spencer 2017	D - OTEC, solar		D - Generic				D - Aquaculture
van Wijk 2017	C - Offshore wind, biomass, solar		C - 500 MW scale			C – liquid hydrogen	C - Onshore activities
Yongqiang 2017	D – Wave				D – Floating platform		D – Onshore activities

6 Unique Aspects of Marine Energy to Hydrogen

Section 4 of this report discussed specific applications, highlighting some of the potential applications for integrating marine energy and hydrogen for marine applications. Many of these applications will be affected by the same or similar aspects that are unique to these applications, and often these unique system effects are not well characterized.

6.1 Geographic Co-Location

Operating complex systems in an offshore environment is often significantly more expensive and challenging than operating similar operations onshore, so the marine energy-H₂ applications that are most likely to be economical are those that must be operated offshore regardless of the energy source. Some examples of applications that are innately offshore range from aquaculture to remote ocean monitoring.

6.1.1 Possible Benefits

Co-locating energy production and storage with end-use applications has numerous benefits, primarily related to the reduced need for energy transportation. The need to supply energy in the form of fuels or electrons can be a major cost because of the added infrastructure in the form of lengthy cables, pipelines, or refueling vessels. It can also limit the duration of deployments because of practical limitations to onboard energy storage. In these situations, marine energy-H₂ systems may be well positioned to supply high-reliability fuel to systems without the need for external energy inputs.

6.1.2 Challenges of Marine Energy and H₂

Although the production of hydrogen on-site from marine energy reduces or even eliminates the need for power or fuel supplies from onshore, it is still an open question whether the full system costs will be lower with on-site energy production and storage. Further techno-economic analysis will need to be conducted for specific applications to determine whether marine energy-H₂ energy systems result in higher or lower costs over the lifetime of a system.

6.1.3 Related Metrics To Evaluate Systems

The clearest metric related to geographic co-location will be the distance between a viable location for collecting marine energy and the location(s) of the end use. This may also be related to the range over which the end use is conducted.

6.2 Power Variability and Predictability

Depending on the location and type of marine energy resource, the power captured can vary significantly on timescales ranging from seconds to months. These variations require a solution that can capture and effectively utilize a broad range of power inputs.

6.2.1 Possible Benefits

Hydrogen may couple particularly well with highly variable energy resources that vary at both short and long timescales. When considering second-by-second variability, electrolyzers have been demonstrated to respond to step changes in the electrical power supply with time constants below 1 second. For seasonal variability, hydrogen may be an appropriate energy storage option

to complement batteries, despite lower energy efficiencies, because of the high energy intensity (W/kg) and virtually no self-discharge over long time periods.

6.2.2 Challenges of Marine Energy and H₂

Highly variable power creates challenges for sizing and operating combined marine energy-H₂ systems. Electrolyzers generally have an allowable turndown in applied electrical power of roughly 10:1, so it is possible to both oversize and undersize an electrolyzer relative to the marine energy resource. Turning electrolyzers on and off repeatedly may also degrade the electrolyzer stacks and related equipment, so it is often beneficial to include a battery that is large enough to reduce the number of on/off cycles that the electrolyzer is subjected to.

6.2.3 Related Metrics To Evaluate Systems

The impacts of power variability and unpredictability will be largely related to the implied storage requirements. Some possible drivers of the storage requirements will be the average and instantaneous power requirements of the end use and how closely those values match the marine energy resource at various timescales. Some end uses may be more flexible in their demand patterns, possibly lowering storage requirements, or conversely may have strict reliability requirements that could imply larger storage requirements.

6.3 Purifying Water for Hydrogen Production

Producing hydrogen via electrolysis consumes roughly 9 L of water per 1 kg of hydrogen in addition to any other water losses (e.g., from evaporation). For most types of electrolysis, this water must be purified to eliminate compounds that could damage or “poison” the materials in the electrolyzer. The level of purification can range from deionized water with resistivities higher than 1 MΩ-cm for PEM electrolyzers to lightly filtered brine for DSE.

6.3.1 Possible Benefits

By locating hydrogen production offshore, the system is definitionally co-located with a large body of water. Although this will require additional purification equipment, independence from a municipal water supply may be beneficial, especially in areas experiencing water scarcity.

6.3.2 Challenges of Marine Energy and H₂

The primary challenge as alluded to earlier is the requirement for water purification. Offshore deployment and operation of a water purification system could significantly increase capital and maintenance costs, impacting the economic viability of these systems. Additionally, the consumption of seawater and the discharge of compounds removed by purification may have undesirable environmental impacts depending on the size and location of these systems.

6.3.3 Related Metrics To Evaluate Systems

The clearest metric that could be used to evaluate systems in line with this aspect is the purity of water required by the electrolyzer. This may be further evaluated for the effects of specific contaminants, which could potentially reduce the purification required. Contaminants in process water may also affect the balance of plant (e.g., pumps, instruments, piping), so some filtration and/or purification is likely to be required in any system.

6.4 Environmental Effects

Deployment and operation of heavy equipment can disrupt or even destroy sensitive ecologies around the deployment areas. These disturbances come in many forms including acoustic, mechanical, chemical, and biological.

6.4.1 Possible Benefits

Noise pollution can have devastating effects on local marine life, and fuel-cell-powered vehicles are often significantly quieter than their comparable, internal combustion counterparts.

Additionally, fuel cells do not produce any emissions beyond heat and water. Most electrolysis systems similarly do not produce any byproducts beyond oxygen and heat except for some DSE systems that can produce chlorine gas.

6.4.2 Challenges of Marine Energy and H₂

As stated earlier, an electrolysis system produces oxygen and can produce chlorine if chloride ions are present in the feedwater. Depending on the size and location of an electrolysis system, it may be necessary to capture byproducts like oxygen, chlorine, or concentrated brine to mitigate local environmental effects. Large electrolysis systems may also draw enough water to create a local environmental impact that would need to be evaluated. Additionally, the contaminants that are removed from the seawater that is consumed by electrolysis must be disposed of safely and with minimal ecological impact.

6.4.3 Related Metrics To Evaluate Systems

Environmental impacts can be difficult to identify and quantify, so the relevant metrics will be dependent on the specific details of each deployment. Some metrics that are likely to be universally important include the types and quantities of emitted and stored fluids (e.g., hydrogen, ammonia, alkaline solutions). The physical configuration of the devices and how that interacts with the local environment is likely to be important—especially if the device contacts the seafloor. Finally, it will be important to identify if moving components could harm local flora or fauna, much in the same way that wind turbines are designed to avoid impacting sensitive bat and bird populations.

6.5 Valuable Coproducts

The primary byproduct from producing hydrogen via electrolysis is gaseous oxygen, which is normally vented because it is not economical to capture. Electrolysis of saline water can also produce chlorine gas as a byproduct, which is generally treated as a hazardous waste that must be safely disposed of. When considering offshore deployments, these byproducts may be considered in a different light with new challenges and opportunities.

6.5.1 Possible Benefits

Fuel cells and most other devices that consume hydrogen also require oxygen to complete the chemical reaction to produce water and power. In onshore applications, this oxygen is freely available as a constituent of ambient air; however, in subsea applications oxygen is scarce. In marine energy-H₂ applications that take place below the surface, it may be economical to capture the produced oxygen, especially considering that it is much more concentrated than the oxygen in our atmosphere. Another possible product of electrolysis of saline water is chlorine gas. This

may be useful if deployed carefully to address biofouling, which can damage or otherwise negatively affect equipment that is deployed in a marine environment.

6.5.2 Challenges of Marine Energy and H₂

Identifying applications for potentially valuable coproducts that are both technically and economically feasible will be one of the largest challenges to capturing and using those coproducts. The requirement of identifying an application where both hydrogen and another byproduct are valuable will further constrain the number of feasible deployments and reduce the scale at which these systems could be deployed.

6.5.3 Related Metrics To Evaluate Systems

The key metric to understand this aspect of marine-energy-to-hydrogen systems will be the value of a given coproduct to the relevant end users. This may then be compared to the additional costs related to capturing and transporting the coproduct to that end user to determine the feasibility of the product(s).

7 Conclusions

This fact-finding report provides information on the benefits and technical challenges of combining marine energy and hydrogen generation technologies. The information and recommendations provided herein are based primarily on a broad literature survey focused on the technologies needed to enable commercial marine energy-H₂ systems. As part of this effort, NREL held a workshop attended by technology experts from industry, academia, national labs, and government entities to explore the R&D challenges and opportunities for combined marine energy-H₂ systems (Thorson and Matthews 2022). We found that while there is a significant amount of technology development and systems integration R&D needed to realize commercial marine energy-H₂ systems, we did not identify any fundamental technical challenges that would prevent the development of successful technologies.

Marine energy-H₂ systems have attributes that address some of the fundamental challenges associated with harnessing marine energy and could enable the development of both utility-scale and blue economy markets. Marine energy-H₂ systems could help overcome the challenge of making marine energy available when and where needed. While marine energy resources are vast (see Section 2), much of the resource is located far from load centers or grid infrastructure (e.g., Alaska or in the U.S. exclusive economic zone surrounding the U.S. Pacific Ocean territories). Using marine energy-H₂ systems to generate hydrogen in these remote locations and then storing and transporting it to where it is needed would vastly expand the harnessable marine energy resource.

Although much of the available marine energy is located far from population centers, there are significant areas of overlap with shipping and other offshore activities. This overlap could further the development of the hydrogen economy by enabling offshore fueling, which may be key to decarbonizing activities with high energy requirements (e.g., large-scale shipping). The growth of hydrogen use in these industries is likely to support the adoption of hydrogen in surrounding, related industries that would benefit as a whole from shared infrastructure and economies of scale.

Another key benefit of generating hydrogen using marine energy is that the process can smooth inherent periodicity in marine energy resources. For example, tidal resources are diurnal or semi-diurnal, and ocean waves that contain the most energy have long periods (i.e., longer than 8 seconds) and vary in intensity on timescales of hours and days. Generating hydrogen using marine energy that can meet consistent energy demands directly mitigates the challenge of using marine energy to provide persistent power. Further, once marine energy is converted to hydrogen, it can be stored for long durations at scales that are not currently practical with existing battery technologies (see Section 3). The ability to smooth the intermittency of marine energy and store large amounts of H₂ for long durations makes the marine energy-H₂ system attractive for both utility-scale and blue economy applications where on-demand power is needed.

Significant advancement of marine energy technology is needed before the potential of combining marine energy and hydrogen generation technologies can be realized. In the United States, the first generation of commercial marine energy devices are just beginning to undergo multiyear testing, and the technologies are at a nascent stage of development. Nevertheless, the potential benefits of marine energy-H₂ systems identified in this report motivate future R&D efforts exploring the most effective ways to combine marine energy and hydrogen generation technologies. Accordingly, combining marine energy and hydrogen technologies can provide innovations that will enable marine energy and hydrogen technologies to contribute to the world's future renewable energy needs.

7.1 Identified R&D Challenges

There are numerous science and engineering challenges that present a barrier to the widespread adoption of marine energy-H₂ systems. We identified the following near-term R&D challenges that must be addressed to enable the development of a commercially successful marine energy-H₂ industry:

- The sizing and operation of the water purification, electrolysis, hydrogen storage, and marine energy device will depend on both technical and economic constraints. Determining the correct sizing of the system components will require the development of a techno-economic model that has been customized for marine-energy-to-hydrogen systems in non-grid applications.
- The breadth of possible combinations and applications of different marine energy-H₂ technologies must be narrowed to enable focused R&D efforts that move technologies toward commercial viability.
- Support for pilot projects in the areas identified in this report are necessary for wider adoption due to the risk and cost associated with the deployment of new marine technologies.
- To enable the responsible and equitable adoption of marine energy-H₂ technologies, it is important to begin early engagement with historically underserved island and coastal communities who will benefit from and be impacted by the deployment of these technologies.
- There is a need to develop control strategies that enable the efficient combination and optimization of electrolysis, marine energy, and balance-of-plant components.

- Marine energy resource forecasting and hydrogen demand forecasting models need to be integrated with system designs to ensure marine energy-H₂ systems can meet the energy needs of the marine sector.
- Hydrogen implementation in new industries will require the development of relevant standards. Researchers should engage with the codes and standards community that are developing the next generation of guidelines.
- The transition from traditional fuels to hydrogen will also require the development of new operating procedures, safety controls, and training standards. These will be especially important in applications that involve the handling of large amounts of hydrogen.
- The implementation of hydrogen as a primary energy storage is currently limited in industries like shipping by the additional space required to store similar quantities of energy in the form of hydrogen. Additional research into high-density hydrogen storage with applications to the marine technologies where there are barriers to the use of existing hydrogen storage technologies will be necessary.

7.2 The Future of Marine Energy-H₂ Systems

Marine energy-H₂ systems have several attributes that could help unlock the potential of marine energy for utility-scale and blue economy applications. Although there are significant R&D challenges that must be overcome to realize this potential, we did not identify any insurmountable R&D challenges that would preclude the development of marine energy-H₂ systems. Still, while we anticipate that commercial marine energy-H₂ systems will become possible in the future, creative solutions to the R&D challenges identified above are required to realize this opportunity. New investments through H₂@Scale and the Hydrogen Energy Earthshot, along with lessons learned from recent global progress in the development and deployment of marine energy and offshore wind projects generating hydrogen, are expected to accelerate progress.

References

- Aderinto, Tunde and Hua Li. 2019. “Review on Power Performance and Efficiency of Wave Energy Converters.” *Energies* 12 (22): 4329.
- Ahluwalia, R.K., D.D. Papadias, J.-K. Peng, and H.S. Roh. 2019. “System Level Analysis of Hydrogen Storage Options.” Presented at the DOE Hydrogen and Fuel Cells Program 2019 Annual Merit Review, Washington, D.C.
- Ahmadi, Pouria, Ibrahim Dincer, and Marc A. Rosen. 2013. “Energy and Exergy Analyses of Hydrogen Production via Solar-Boosted Ocean Thermal Energy Conversion and PEM Electrolysis.” *International Journal of Hydrogen Energy* 38 (4): 1795–1805.
<https://doi.org/10.1016/j.ijhydene.2012.11.025>.
- Air Liquide. 2017. “USA: Air Liquide Operates the World’s Largest Hydrogen Storage Facility.” Press release, January 3, 2017. <https://www.airliquide.com/group/press-releases-news/2017-01-03/usa-air-liquide-operates-worlds-largest-hydrogen-storage-facility>.
- Alaska Energy Authority. 2015. “Power Cost Equalization Program: Statistical Data by Community.” Alaska Energy Authority, Anchorage, Alaska.
- Anderson, J. H. 1975. “Sea Thermal Power as a Hydrogen and Methanol Generator.” In *Hydrogen Energy: Part A*, edited by T. Nejat Veziroğlu, 197–207. Boston, MA: Springer.
https://doi.org/10.1007/978-1-4684-2607-6_14.
- Anwar, M. B., M. S. E. Moursi, and W. Xiao. 2017. “Novel Power Smoothing and Generation Scheduling Strategies for a Hybrid Wind and Marine Current Turbine System.” *IEEE Transactions on Power Systems* 32 (2): 1315–26. <https://doi.org/10.1109/TPWRS.2016.2591723>.
- Augustine, Chad, Richard Bain, Jamie Chapman, Paul Denholm, Easan Drury, Douglas G. Hall, Eric Lantz, et al. 2012. *Renewable Electricity Futures Study Volume 2: Renewable Electricity Generation and Storage Technologies*. Golden, CO: National Renewable Energy Laboratory. NREL/TP-6A20-52409-2.
- Avery, W. H., D. Richards, and G. L. Dugger. 1985. “Hydrogen Generation by OTEC Electrolysis, and Economical Energy Transfer to World Markets via Ammonia and Methanol.” *International Journal of Hydrogen Energy* 10 (11): 727–36. [https://doi.org/10.1016/0360-3199\(85\)90108-9](https://doi.org/10.1016/0360-3199(85)90108-9).
- Awad, Hadia and Mustafa Gül. 2018. “Load-Match-Driven Design of Solar PV Systems at High Latitudes in the Northern Hemisphere and Its Impact on the Grid.” *Solar Energy* 173: 377–97.
- Ayers, Katherine E., Everett B. Anderson, Christopher Capuano, Blake Carter, Luke Dalton, Greg Hanlon, Judith Manco, and Michael Niedzwiecki. 2010. “Research Advances towards Low Cost, High Efficiency PEM Electrolysis.” *ECS Transactions* 33 (1): 3–15.
<https://doi.org/10.1149/1.3484496>.

Babarit, A. 2015. “A Database of Capture Width Ratio of Wave Energy Converters.” *Renewable Energy* 19.

Babarit Aurélien, Jean-Christophe Gilloteaux, Gaël Clodic, Maxime Duchet, Alexandre Simoneau, and Max F. Platzer. 2018. “Techno-Economic Feasibility of Fleets of Far Offshore Hydrogen-Producing Wind Energy Converters.” *International Journal of Hydrogen Energy* 43 (15): 7266–89. <https://doi.org/10.1016/j.ijhydene.2018.02.144>.

Bankston, J. David and Fred Eugene Baker. 1995. “Powering Aquaculture Equipment.” SRAC Publication No. 375. Southern Regional Aquaculture Center. <https://srac.tamu.edu/factsheets/serve/72>.

Bao, Di, Qi Zhang, Fan-Lu Meng, Hai-Xia Zhong, Miao-Miao Shi, Yu Zhang, Jun-Min Yan, Qing Jiang, Xin-Bo Zhang. 2017. “Electrochemical Reduction of N₂ under Ambient Conditions for Artificial N₂ Fixation and Renewable Energy Storage Using N₂/NH₃ Cycle.” *Advanced Materials* 29 (3): 1604799. <https://doi.org/10.1002/adma.201604799>.

Baragona, Steve. 2016. “This Coral Restoration Technique Is ‘Electrifying’ a Balinese Village.” *Smithsonian Magazine*, May 25, 2016. <https://www.smithsonianmag.com/science-nature/coral-restoration-technique-electrifying-balinese-village-180959206/>.

Barakat, M.R., B. Tala-Ighil, H. Gualous, and D. Hissel. 2019. “Modeling of a Hybrid Marine Current-Hydrogen Active Power Generation System.” *International Journal of Hydrogen Energy* 44 (19): 9621–35. <https://doi.org/10.1016/j.ijhydene.2018.10.020>.

Barry, Amanda, Alexis Wolfe, Christine English, Colleen Ruddick, and Devinn Lambert. 2016. *National Algal Biofuels Technology Review*. Washington, D.C.: Bioenergy Technologies Office.

Beaulieu, Stace E. and Kamil M. Szafranski. 2020. “InterRidge Global Database of Active Submarine Hydrothermal Vent Fields Version 3.4.” *PANGAEA*. <https://doi.org/10.1594/PANGAEA.917894>.

Bicer, Yusuf and Ibrahim Dincer. 2018. “Clean Fuel Options with Hydrogen for Sea Transportation: A Life Cycle Approach.” *International Journal of Hydrogen Energy* 43 (2): 1179–93. <https://doi.org/10.1016/j.ijhydene.2017.10.157>.

Bhatnagar D., S. Bhattacharya, D.C. Preziuso, S. Hanif, R.S. O’Neil, M.E. Alam, V.H. Chalishazar, et al. 2021. *Grid Value Proposition of Marine Energy: A Preliminary Analysis*. Richland, WA: Pacific Northwest National Laboratory. PNNL-31123. <https://doi.org/10.2172/1833512>.

Blanco-Fernández, Pilar and Francisco Pérez-Arribas. 2017. “Offshore Facilities to Produce Hydrogen.” *Energies* 10 (6): 783. <https://doi.org/10.3390/en10060783>.

Bolam, Robert Cameron, Yuriy Vagapov, and Alecksey Anuchin. 2020. “A Review of Electrical Motor Topologies for Aircraft Propulsion.” In *2020 55th International Universities Power Engineering Conference (UPEC)*, 1–4 September, Turin, Italy. <https://doi.org/10.1109/UPEC49904.2020.9209783>.

Bouwman, Peter. 2016. “Fundamentals of Electrochemical Hydrogen Compression.” In *PEM Electrolysis for Hydrogen Production: Principles and Applications* (Boca Raton, FL: CRC Press).

Brasseur, Lorraine, Mario Tamburri, and Al Pluedemann. 2010. “Sensor Needs and Readiness Levels for Ocean Observing: An Example from the Ocean Observatories Initiative (OOI).” In *Proceedings of OceanObs’09: Sustained Ocean Observations and Information for Society (Vol. 2)*, Venice, Italy: European Space Agency. <https://doi.org/10.5270/OceanObs09.cwp.10>.

Brauns, Jörn and Thomas Turek. 2020. “Alkaline Water Electrolysis Powered by Renewable Energy: A Review.” *Processes* 8 (2): 248. <https://doi.org/10.3390/pr8020248>.

Brown, Isabela N. and Michael F. Aldridge. 2019. “Power Models and Average Ship Parameter Effects on Marine Emissions Inventories.” *Journal of the Air & Waste Management Association* 69 (6): 752–63. <https://doi.org/10.1080/10962247.2019.1580229>.

Brynolf, Selma, Erik Fridell, and Karin Andersson. 2014. “Environmental Assessment of Marine Fuels: Liquefied Natural Gas, Liquefied Biogas, Methanol and Bio-Methanol.” *Journal of Cleaner Production* 74: 86–95. <https://doi.org/10.1016/j.jclepro.2014.03.052>.

Buhagiar, Daniel and Tonio Sant. 2017. “Modelling of a Novel Hydro-Pneumatic Accumulator for Large-Scale Offshore Energy Storage Applications.” *Journal of Energy Storage* 14 (2): 283–94. <https://doi.org/10.1016/j.est.2017.05.005>.

Bunn, Malachi, Alex Yokochi, and Annette von Jouanne. 2014. “Electrochemical Antifouling Technology for Replacement of Heavy Metal and Organic Biocides in Marine Hydrokinetic Energy Generation.” In *2014 IEEE Conference on Technologies for Sustainability (SusTech)*, 24–26 July, Portland, OR. <https://doi.org/10.1109/SusTech.2014.7046214>.

Burtch, John Christopher. 2006. “Apparatus For Production of Hydrogen Gas Using Wind and Wave Action.” Patent issued September 1, 2006. <https://patents.google.com/patent/US20080231053A1/en>.

Chen, S., H. Jang, J. Wang, Q. Qin, X. Liu, and J. Cho. 2020. “Bimetallic metal–organic framework-derived MoFe-PC microspheres for electrocatalytic ammonia synthesis under ambient conditions.” *Journal of Materials Chemistry A* 8: 2099–2104. <https://doi.org/10.1039/C9TA10524G>.

Chevalier, Patrice Christian Philippe Charles. 2016. “Self-contained multi-source multi-source continuous marine power plant and associated methods.” Patent FR3022953A1, filed June 27, 2014, and issued January 1, 2016. <https://patents.google.com/patent/FR3022953A1/en>.

Chu Van, Thuy, Jerome Ramirez, Thomas Rainey, Zoran Ristovski, and Richard J. Brown. 2019. “Global Impacts of Recent IMO Regulations on Marine Fuel Oil Refining Processes and Ship Emissions.” *Transportation Research Part D: Transport and Environment* 70 (May): 123–34. <https://doi.org/10.1016/j.trd.2019.04.001>.

- Colucci A., V. Boscaino, G. Cipriani, D. Curto, V. Di Dio, V. Franzitta, M. Trapanese, and A. Viola. 2015. “An Inertial System for the Production of Electricity and Hydrogen from Sea Wave Energy.” In *OCEANS 2015 - MTS/IEEE Washington*, 19–22 October, Washington, D.C. <https://doi.org/10.23919/OCEANS.2015.7404569>.
- Curto, Domenico and Marco Trapanese. 2017. “Experimental Tests on Hydrogen Production from Seawaves Energy.” In *OCEANS 2017 - Anchorage*, 18–21 September, Anchorage, AK.
- d’Amore-Domenech, Rafael and Teresa J. Leo. 2019. “Sustainable Hydrogen Production from Offshore Marine Renewable Farms: Techno-Energetic Insight on Seawater Electrolysis Technologies.” *ACS Sustainable Chemistry & Engineering* 7 (9): 8006–22. <https://doi.org/10.1021/acssuschemeng.8b06779>.
- Deng, Jiao, Jesus A. Iñiguez, and Chong Liu. 2018. “Electrocatalytic Nitrogen Reduction at Low Temperature.” *Joule* 2 (5): 846–856. <https://doi.org/10.1016/j.joule.2018.04.014>.
- de-Troya, José J., Carlos Álvarez, Carlos Fernández-Garrido, and Luis Carral. 2016. “Analysing the Possibilities of Using Fuel Cells in Ships.” *International Journal of Hydrogen Energy* 41 (4): 2853–66. <https://doi.org/10.1016/j.ijhydene.2015.11.145>.
- Dhanak, Manhar R. and Nikolaos I. Xiros. 2016. *Springer Handbook of Ocean Engineering*. Springer.
- Di Blasi, A., L. Andaloro, S. Siracusano, N. Briguglio, G. Brunaccini, A. Stassi, A.S. Aricò, and V. Antonucci. 2013. “Evaluation of Materials and Components Degradation of a PEM Electrolyzer for Marine Applications.” *International Journal of Hydrogen Energy* 38 (18): 7612–15. <https://doi.org/10.1016/j.ijhydene.2012.10.062>.
- Dias, Véronique, Maxime Pochet, Francesco Contino, and Hervé Jeanmart. 2020. “Energy and Economic Costs of Chemical Storage.” *Frontiers in Mechanical Engineering* 6. <https://doi.org/10.3389/fmech.2020.00021>.
- Dresp, Sören, Fabio Dionigi, Malte Klingenhof, and Peter Strasser. 2019. “Direct Electrolytic Splitting of Seawater: Opportunities and Challenges.” *ACS Energy Letters* 4 (4): 933–42. <https://doi.org/10.1021/acseenergylett.9b00220>.
- Dugger, G. L. and E. J. Francis. 1977. “Design of an Ocean Thermal Energy Plant Ship to Produce Ammonia via Hydrogen.” *International Journal of Hydrogen Energy* 2 (3): 231–49. [https://doi.org/10.1016/0360-3199\(77\)90020-9](https://doi.org/10.1016/0360-3199(77)90020-9).
- Dysarsz, Hans. 2016. “Translating foil system for harvesting kinetic energy from wind and flowing water.” World Intellectual Property Organization WO2016109895A1, patent filed January 7, 2016, issued July 14, 2016. <https://patents.google.com/patent/WO2016109895A1/en>.
- Eichman, J., K. Harrison, and M. Peters. 2014. *Novel Electrolyzer Applications: Providing More Than Just Hydrogen*. Golden, CO: National Renewable Energy Laboratory. NREL/TP-5400-61758. <https://www.nrel.gov/docs/fy14osti/61758.pdf>.

European Marine Energy Centre (EMEC). 2017. “SURF ‘N’ TURF: An Innovative Community Project in Orkney That Uses Surplus Electricity Generated from Renewable Energy to Split Water, Making Hydrogen Gas as a Fuel.” <https://www.surfnturf.org.uk/index.php>.

FIBA. 2021. “Renewable Fuels.” FIBA Technologies Inc. blog. <https://www.fibatech.com/products/product-applications/renewable-fuels/>.

Food and Agriculture Organization of the United Nations (FAO). 2016. *The State of World Fisheries and Aquaculture: Contributing to Food Security and Nutrition for All*. Rome: FAO.

Franzitta, Vincenzo, Domenico Curto, Davide Rao, and Alessia Viola. 2016. “Hydrogen Production from Sea Wave for Alternative Energy Vehicles for Public Transport in Trapani (Italy).” *Energies* 9 (10): 850. <https://doi.org/10.3390/en9100850>.

Garrett-Glaser, Brian. 2020. “Will Hydrogen Fuel Cells Play a Role in the VTOL Revolution?” *Aviation Today*, April 16, 2020. <https://www.aviationtoday.com/2020/04/16/will-hydrogen-fuel-cells-play-a-role-in-the-vtol-revolution/>.

Gentry, Rebecca R., Sarah E. Lester, Carrie V. Kappel, Crow White, Tom W. Bell, Joel Stevens, and Steven D. Gaines. 2017. “Offshore Aquaculture: Spatial Planning Principles for Sustainable Development.” *Ecology and Evolution* 7 (2): 733–43.

Gilloteaux, Jean-Christophe and Aurélien Babarit. 2017. “Preliminary Design of a Wind Driven Vessel Dedicated to Hydrogen Production.” In *ASME 2017 36th International Conference on Ocean, Offshore and Arctic Engineering*, 25–30 June 2017, Trondheim, Norway. <https://doi.org/10.1115/OMAE2017-61408>.

Green, Rebecca, Andrea Copping, Robert J Cavagnaro, Deborah Rose, Dorian Overhus, and Dale Jenne. 2019. “Enabling Power at Sea: Opportunities for Expanded Ocean Observations through Marine Renewable Energy Integration.” In *OCEANS 2019 MTS/IEEE SEATTLE*, 27–31 October, Seattle, WA.

Guangrong, Zou. 2017. *Ship Energy Efficiency Technologies – Now and the Future*. VTT Technical Research Centre of Finland. <https://www.vttresearch.com/sites/default/files/pdf/technology/2017/T306.pdf>.

Gunn, Kester and Clym Stock-Williams. 2012. “Quantifying the Global Wave Power Resource.” *Renewable Energy* 44: 296–304.

Haas, Kevin A., Hermann M. Fritz, Steven P. French, Brennan T. Smith, and Vincent Neary. 2011. *Assessment of Energy Production Potential from Tidal Streams in the United States*. <https://www.energy.gov/sites/default/files/2013/12/f5/1023527.pdf>.

Habermeyer, Felix, Minna Kurkela, Esa Kurkela, and Sandra Adelung. 2018. *Review of Electrolysis Technologies and Their Integration Alternatives*. VTT Technical Research Centre of Finland Ltd.

- Harrison, K. W., G. D. Martin, T. G. Ramsden, W. E. Kramer, and F. J. Novachek. 2009. *The Wind-To-Hydrogen Project: Operational Experience, Performance Testing, and Systems Integration*. Golden, CO: National Renewable Energy Laboratory. NREL/TP-550-44082. <https://www.nrel.gov/docs/fy09osti/44082.pdf>.
- Hu, Lin, Zhuo Xing, and Xiaofeng Feng. 2020. “Understanding the Electrocatalytic Interface for Ambient Ammonia Synthesis.” *ACS Energy Letters* 5 (2): 430–436. <https://doi.org/10.1021/acsenerylett.9b02679>.
- Hughes, H. and L. A. Gish. 2017. “Inductive Recharging for a Small Commercial Autonomous Underwater Vehicle.” In *OCEANS 2017-Anchorage*, 18–21 September 2017.
- International Maritime Organization. 2016. “IMO Sets 2020 Date for Ships to Comply with Low Sulphur Fuel Oil Requirement.” Media Centre, Latest News, October 28, 2016. <https://www.imo.org/en/MediaCentre/PressBriefings/Pages/MEPC-70-2020sulphur.aspx>.
- International Renewable Energy Agency (IRENA). 2020. *Green Hydrogen Cost Reduction: Scaling Up Electrolysers to Meet the 1.5°C Climate Goal*. Abu Dhabi, United Arab Emirates: IRENA. https://www.irena.org/-/media/Files/IRENA/Agency/Publication/2020/Dec/IRENA_Green_hydrogen_cost_2020.pdf.
- Jambeck, J.R., R. Geyer, C. Wilcox, T.R. Siegler, M. Perryman, A. Andrady, R. Narayan, and K.L. Law. 2015. “Plastic waste inputs from land into the ocean.” *Science* 347 (6223): 768–771.
- Kazim, Ayoub. 2005. “Hydrogen Production through an Ocean Thermal Energy Conversion System Operating at an Optimum Temperature Drop.” *Applied Thermal Engineering* 25 (14): 2236–46. <https://doi.org/10.1016/j.applthermaleng.2005.01.003>.
- Khan, M. J., G. Bhuyan, M. T. Iqbal, and J. E. Quaiocoe. 2009. “Hydrokinetic energy conversion systems and assessment of horizontal and vertical axis turbines for river and tidal applications: A technology status review.” *Applied Energy* 86 (10): 1823–1835. <https://doi.org/10.1016/j.apenergy.2009.02.017>.
- Khosravi, A., Sanna Syri, M. E. H. Assad, and M. Malekan. 2019. “Thermodynamic and Economic Analysis of a Hybrid Ocean Thermal Energy Conversion/Photovoltaic System with Hydrogen-Based Energy Storage System.” *Energy* 172 (April): 304–19. <https://doi.org/10.1016/j.energy.2019.01.100>.
- Kilcher, Levi, Michelle Fogarty, and Michael Lawson. 2021. *Marine Energy in the United States: An Overview of Opportunities*. Golden, CO: National Renewable Energy Laboratory. NREL/TP-5700-78773. <https://www.nrel.gov/docs/fy21osti/78773.pdf>.
- Kilcher, Levi, and Robert Thresher. 2016. *Marine Hydrokinetic Energy Site Identification and Ranking Methodology Part I: Wave Energy*. Golden, CO: National Renewable Energy Laboratory. NREL/TP-5000-66038. <https://www.nrel.gov/docs/fy17osti/66038.pdf>.
- Kim, J. and C. Park. 2010. “Wind Power Generation with a Parawing on Ships, a Proposal.” *Energy* 35 (3): 1425–32. <https://doi.org/10.1016/j.energy.2009.11.027>.

Kim, Jong Suk, Jun Chen, and Humberto E. Garcia. 2016. “Modeling, Control, and Dynamic Performance Analysis of a Reverse Osmosis Desalination Plant Integrated within Hybrid Energy Systems.” *Energy* 112: 52–66. <https://doi.org/10.1016/j.energy.2016.05.050>.

Klein, Alice. 2018. “Divers are attempting to regrow Great Barrier Reef with electricity.” *New Scientist*, September 20, 2018. <https://www.newscientist.com/article/2180369-divers-are-attempting-to-regrow-great-barrier-reef-with-electricity/>.

Klerke, Asbjørn, Claus Hviid Christensen, Jens K. Nørskov, and Tejs Vegge. 2008. “Ammonia for hydrogen storage: challenges and opportunities.” *Journal of Materials Chemistry* 18: 2304–2310. <https://doi.org/10.1039/B720020J>.

Kotowicz, Janusz, Daniel Węcel, and Michał Jurczyk. 2018. “Analysis of Component Operation in Power-to-Gas-to-Power Installations.” *Applied Energy* 216: 45–59. <https://doi.org/10.1016/j.apenergy.2018.02.050>.

Kris, Hyde and Cooley Graham. 2016. “Renewable energy system.” GB2539700A, patent filed June 25, 2015, issued December 28, 2016. <https://patents.google.com/patent/GB2539700A/en>.

Kumano, Katsuyuki. 2018. “Hydrogen energy supply system using ocean current power generation.” Patent US10138563B2, filed August 1, 2015, issued November 27, 2018. <https://patents.google.com/patent/US10138563B2/en>.

Lan, Rong and Shanwen Tao. 2014. “Ammonia as a suitable fuel for fuel cells.” *Frontiers in Energy Research* 2 (35). <https://doi.org/10.3389/fenrg.2014.00035>.

Lan, Rong, John T.S. Irvine, and Shanwen Tao. 2012. “Ammonia and related chemicals as potential indirect hydrogen storage materials.” *International Journal of Hydrogen Energy* 37 (2): 1482–1494. <https://doi.org/10.1016/j.ijhydene.2011.10.004>.

Lata-García, Juan, Francisco Jurado, Luis M. Fernández-Ramírez, and Higinio Sánchez-Sainz. 2018. “Optimal Hydrokinetic Turbine Location and Techno-Economic Analysis of a Hybrid System Based on Photovoltaic/Hydrokinetic/Hydrogen/Battery.” *Energy* 159 (September): 611–20. <https://doi.org/10.1016/j.energy.2018.06.183>.

Leanna, Andrew J., Robert K. Wynne, Robert Christopher Utz, Richard D. Sickenberger, Antonio D. Reis, Jason T. Foess, Robert K. Sievers, Grady M. Icard, and Thomas I. Valdez. 2019. *Large-Scale Energy Delivery to Enable Persistent Monitoring Subsea*. Hunt Valley, MD: Teledyne Energy System.

Lee, Joonkoo, Mary Turnipseed, and Lukas Brun. 2012. “Market and Technology Trends in Sensors and Instrumentation.” *Marine Technology*. <https://doi.org/10.13140/RG.2.1.4783.4641>.

Lemmon, E. W., Ian H. Bell, M. L. Huber, and M. O. McLinden. 2018. *NIST Standard Reference Database 23: Reference Fluid Thermodynamic and Transport Properties-REFPROP* (version 10.0). NIST. <https://www.nist.gov/srd/refprop>.

- Leonard, Ralph L. 2017. “Ocean-going hydrogen generator.” US9657399B2, patent filed July 16, 2015, issued May 23, 2017. <https://patents.google.com/patent/US9657399B2/en>.
- Lin, Y.-X., S.-N. Zhang, Z.-H. Xue, J.-J. Zhang, H. Su, T.-J. Zhao, G.-Y. Zhai, X.-H. Li, M. Antonietti, and J.-S. Chen. 2019. “Boosting selective nitrogen reduction to ammonia on electron-deficient copper nanoparticles.” *Nature Communications* 10: 4380. <https://doi.org/10.1038/s41467-019-12312-4>.
- Liu, Haohui, Vijay Krishna, Jason Lun Leung, Thomas Reindl, and Lu Zhao. 2018. “Field Experience and Performance Analysis of Floating PV Technologies in the Tropics.” *Progress in Photovoltaics: Research and Applications* 26 (12): 957–67.
- Liu, Jian, Robert J. Cavagnaro, Zhiqun Daniel Deng, Yuyan Shao, Li-Jung Kuo, Manh-Thuong Nguyen, and Vanda Glezakou. 2020. “Renewable Ammonia as an Energy Fuel for Ocean Exploration and Transportation.” *Maine Technology Society Journal* 54 (6): 126–136. <https://doi.org/10.4031/MTSJ.54.6.12>.
- LiVecchi, A., A. Copping, D. Jenne, A. Gorton, R. Preus, G. Gill, R. Robichaud, R. Green, S. Geerlofs, S. Gore, D. Hume, et al. 2019. *Powering the Blue Economy: Exploring Opportunities for Marine Renewable Energy in Maritime Markets*. Washington, D.C.: U.S. Department of Energy Office of Energy Efficiency and Renewable Energy.
- Madsen, R. T., L. E. Klebanoff, S. A. M. Caughlan, J. W. Pratt, T. S. Leach, T. B. Appelgate Jr., S. Z. Kelety, et al. 2020. “Feasibility of the Zero-V: A Zero-Emissions Hydrogen Fuel-Cell Coastal Research Vessel.” *International Journal of Hydrogen Energy* 45 (46): 25328–43.
- Martel, Laura, Paul Smith, Steven Rizea, Joe Van Ryzin, Charles Morgan, Gary Noland, Rick Pavlosky, Michael Thomas, and John Halkyard. 2012. *Ocean Thermal Energy Conversion Life Cycle Cost Assessment, Final Technical Report*. Manassas, VA: Lockheed Martin. DOE/EE/0002663. <https://doi.org/10.2172/1045340>.
- Martin, Joshua, Sam Sprik, Steve Mathison, and Jeff Jetter. 2019. “Validating an Electrolysis System with High Output Pressure.” Presented at the DOE Hydrogen and Fuel Cells Program 2019 Annual Merit Review and Peer Evaluation Meeting, 30 April 2019, Crystal City, VA.
- Mayyas, Ahmad T., Mark F. Ruth, Bryan S. Pivovar, Guido Bender, and Keith B. Wipke. 2019. *Manufacturing Cost Analysis for Proton Exchange Membrane Water Electrolyzers*. Golden, CO: National Renewable Energy Laboratory. NREL/TP-6A20-72740. <https://doi.org/10.2172/1557965>.
- Meier, Konrad. 2014. “Hydrogen Production with Sea Water Electrolysis Using Norwegian Offshore Wind Energy Potentials.” *International Journal of Energy and Environmental Engineering* 5 (2): 104. <https://doi.org/10.1007/s40095-014-0104-6>.
- Menear, John E. 2010. “Deep water generation of compressed hydrogen.” US20100089766A1, patent filed March 18, 2009, issued April 15, 2010. <https://patents.google.com/patent/US20100089766A1/en>.

Miller, Alan Kleinfeld. 2016. “Mitigating global warming by OTEC-induced ocean upwelling.” US20160290701A1, patent filed March 28, 2016, issued October 6, 2016. <https://patents.google.com/patent/US20160290701A1/en>.

Mohanpurkar, Manish, Yusheng Luo, Danny Terlip, Fernando Dias, Kevin Harrison, Joshua Eichman, Rob Hovsapian, and Jennifer Kurtz. 2017. “Electrolyzers Enhancing Flexibility in Electric Grids.” *Energies* 10 (11): 1836. <https://doi.org/10.3390/en10111836>.

Mukherjee, S., David A. Cullen, Stavros Karakalos, Kexi Liu, Hao Zhang, Shuai Zhao, Hui Xu, Karren L. More, Guofeng Wang, and Gang Wu. 2018. “Metal-organic framework-derived nitrogen-doped highly disordered carbon for electrochemical ammonia synthesis using N₂ and H₂O in alkaline electrolytes.” *Nano Energy* 48: 217–226. <https://doi.org/10.1016/j.nanoen.2018.03.059>.

Nassar, Walid M., Olimpo Anaya-Lara, Khaled H. Ahmed, David Campos-Gaona, and Mohamed Elgenedy. 2020. “Assessment of Multi-Use Offshore Platforms: Structure Classification and Design Challenges.” *Sustainability* 12 (5): 1860.

National Energy Technology Laboratory (NETL). 2017. *Methane Hydrate Science and Technology: A 2017 Update*. Washington, D.C.: DOE. <https://www.netl.doe.gov/sites/default/files/netl-file/2017-Methane-Hydrate-Primer%5B1%5D.pdf>.

National Oceanic and Atmospheric Administration (NOAA). 2018. *From Surface to Seafloor: Exploration of the Water Column*. Silver Spring, MD: NOAA Office of Ocean Exploration and Research. Technical Memorandum OAR OER; 003. <https://doi.org/10.25923/rjx-vn79>.

———. 2020. “Exploring the Ocean with the Power of Waves.” The U.S. Integrated Ocean Observing System (IOOS). January 29, 2020. <https://ioos.noaa.gov/news/exploring-the-ocean-with-the-power-of-waves/>.

National Renewable Energy Laboratory (NREL). 2018. “Compressor Energy.” Composite Data Product CDP INFR 35. Component Energy. <https://www.nrel.gov/hydrogen/assets/images/cdp-infr-35.jpg>.

———. 2020a. “Compressor Energy.” Composite Data Product CDP RETAIL INFR 35. Component Energy. <https://www.nrel.gov/hydrogen/assets/images/cdp-retail-infr-35.20200327.jpg>.

———. 2020b. “Marine Energy Atlas.” <https://maps.nrel.gov/marine-energy-atlas>.

———. 2021. “PRIMRE.” Open Energy Information. Accessed February 9, 2021. <https://openei.org/wiki/PRIMRE>.

National Research Council. 2013. “Ocean Thermal Energy Conversion Resource Assessment.” In *An Evaluation of the U.S. Department of Energy’s Marine and Hydrokinetic Resource Assessments*. Washington, D.C.: The National Academies Press. <https://doi.org/10.17226/18278>.

- Neary, Vincent S., Mirko Previsic, Richard A. Jepsen, Michael J. Lawson, Yi-Hsiang Yu, Andrea E. Copping, Arnold A. Fontaine, Kathleen C. Hallett, and Dianne K. Murray. 2014. *Methodology for Design and Economic Analysis of Marine Energy Conversion (MEC) Technologies*. Albuquerque, NM: Sandia National Laboratories. SAND2014-9040.
- Noia, Giampaolo Francesco and Edwin Kendall Schaffner. 2018. “Floating wave energy conversion island platforms.” AU2017219310A1, patent filed February 17, 2017, issued August 30, 2018. <https://patents.google.com/patent/AU2017219310A1/en>.
- Normani, Franco. 2020. “Ammonia as a Green Shipping Fuel: The Viking Energy Project.” *AZO Cleantech*, May 27, 2020. <https://www.azocleantech.com/article.aspx?ArticleID=1092>.
- NRG. 2018. “Lashto Fish Farm in Haiti - NRG Delivers Solar-Powered Fish Hatchery in the Caribbean.” <http://52.15.66.9/projects/community/lashto-fish-farm-in-haiti/>.
- Ouchi, K. and J. Henzie. 2017. “Hydrogen Generation Sailing Ship: Conceptual Design and Feasibility Study.” In *OCEANS 2017 - Aberdeen*, 19–22 June, Aberdeen, UK. <https://doi.org/10.1109/OCEANSE.2017.8084808>.
- Papadias, D., R. K. Ahluwalia, E. Connelly, and P. Devlin. 2019. “Total Cost of Ownership (TCO) Analysis for Hydrogen Fuel Cells in Maritime Applications – Preliminary Results.” Presented at the H2@Ports Workshop, 10 September, San Francisco, CA. <https://www.energy.gov/sites/prod/files/2019/10/f68/fcto-h2-at-ports-workshop-2019-viii5-ahluwalia.pdf>.
- Pellow, Matthew A., Christopher J. M. Emmott, Charles J. Barnhart, and Sally M. Benson. 2015. “Hydrogen or Batteries for Grid Storage? A Net Energy Analysis.” *Energy & Environmental Science* 8 (7): 1938–52. <https://doi.org/10.1039/C4EE04041D>.
- Penev, Michael. 2013. “Hybrid Hydrogen Energy Storage.” Presented at All-Energy 2013, 22 May 2013, Aberdeen, UK.
- Peterson, David, James Vickers, and Daniel DeSantis. 2020a. “Hydrogen Production Cost From High Temperature Electrolysis – 2020.” DOE Hydrogen and Fuel Cells Program Record 20006. <https://www.hydrogen.energy.gov/pdfs/20006-production-cost-high-temperature-electrolysis.pdf>.
- Peterson, David, James Vickers, and Dan DeSantis. 2020b. “Hydrogen Production Cost From PEM Electrolysis - 2019.” DOE Hydrogen and Fuel Cells Program Record 19009. https://www.hydrogen.energy.gov/pdfs/19009_h2_production_cost_pem_electrolysis_2019.pdf.
- Pimm, Andrew J., Seamus D. Garvey, and Maxim de Jong. 2014. “Design and Testing of Energy Bags for Underwater Compressed Air Energy Storage.” *Energy* 66: 496–508. <https://doi.org/10.1016/j.energy.2013.12.010>.
- Pitts, Thomas H. 1989. “Submerged ocean current electrical generator and method for hydrogen production.” US4850190A, patent filed May 9, 1988, issued July 25, 1989. <https://patents.google.com/patent/US4850190A/en>.

Plaza, Juan. 2017. “Will Hydrogen Fuel Cells Help Drones Stay in the Air?” *Commercial UAV News*, June 5, 2017. <https://www.commercialuavnews.com/infrastructure/hydrogen-fuel-cells-drones>.

Pratt, Joseph William. 2017. “Feasibility of the SF-BREEZE: A Zero-Emission Hydrogen Fuel Cell High-Speed Passenger Ferry.” Presented at the SNAME Norcal Chapter Meeting, January 18, 2017.

Raut, Gagee and Navid Goudarzi. 2017. “Hydrogen Production From Renewables: Marine and Hydrokinetic Energy Systems.” In *Volume 6: Energy*, V006T08A094. Tampa, FL: American Society of Mechanical Engineers. <https://doi.org/10.1115/IMECE2017-71859>.

———. 2018. “North Carolina Wave Energy Resource: Hydrogen Production Potential.” In *Volume 1: Fuels, Combustion, and Material Handling; Combustion Turbines Combined Cycles; Boilers and Heat Recovery Steam Generators; Virtual Plant and Cyber-Physical Systems; Plant Development and Construction; Renewable Energy Systems*, V001T06A018. Lake Buena Vista, FL: American Society of Mechanical Engineers. <https://doi.org/10.1115/POWER2018-7388>.

Raye, Robert E. 2002. “Characterization Study of the Florida Current at 26.11 Northern Latitude, 79.50 West Longitude for Ocean Current Power Generation.” Master’s thesis, Florida Atlantic University.

Research and Markets. 2017. “Global \$2.65 Billion Unmanned Underwater Vehicles Market 2017-2021.” *GlobeNewswire*, March 10, 2017. <https://www.globenewswire.com/news-release/2017/03/10/934263/0/en/Global-2-65-Billion-Unmanned-Underwater-Vehicles-Market-2017-2021.html>.

Roach, John. 2020. “Microsoft finds underwater datacenters are reliable, practical and use energy sustainably.” *Microsoft Innovation Stories*, September 4, 2020. <https://news.microsoft.com/innovation-stories/project-natick-underwater-datacenter/>.

Roy, Anthony, François Auger, Florian Dupriez-Robin, Salvy Bourguet, and Quoc Tuan Tran. 2018. “Electrical Power Supply of Remote Maritime Areas: A Review of Hybrid Systems Based on Marine Renewable Energies.” *Energies* 11 (7): 1904. <https://doi.org/10.3390/en11071904>.

Ruth, Mark F., Paige Jadun, Nicholas Gilroy, Elizabeth Connelly, Richard Boardman, A. J. Simon, Amgad Elgowainy, and Jarett Zuboy. 2020. *The Technical and Economic Potential of the H2@Scale Hydrogen Concept within the United States*. Golden, CO: National Renewable Energy Laboratory. NREL/TP-6A20-77610. <https://doi.org/10.2172/1677471>.

Salter, Stephen. 1974. “Wave Power.” *Nature* 249 (June): 720–24. <https://doi.org/10.1038/249720a0>.

Schaber, Christopher, Patrick Mazza, and Roel Hammerschlag. 2004. “Utility-Scale Storage of Renewable Energy.” *The Electricity Journal* 17 (6): 21–29. <https://doi.org/10.1016/j.tej.2004.05.005>.

Schmidt, O. 2017. “Future Cost and Performance of Water Electrolysis: An Expert Elicitation Study.” *International Journal of Hydrogen Energy* 42 (52): 30470–30492. <https://doi.org/10.1016/j.ijhydene.2017.10.045>.

Scott, Alex. 2020. “Ammonia on Route to Fuel Ships and Planes.” *Chemical & Engineering News*, August 12, 2020. <https://cen.acs.org/energy/renewables/Ammonia-route-fuel-ships-planes/98/i31>.

Serna, Álvaro and Fernando Tadeo. 2014. “Offshore Hydrogen Production from Wave Energy.” *International Journal of Hydrogen Energy* 39 (3): 1549–57. <https://doi.org/10.1016/j.ijhydene.2013.04.113>.

Serna, Álvaro, Imene Yahyaoui, Julio E. Normey-Rico, César de Prada, and Fernando Tadeo. 2017. “Predictive Control for Hydrogen Production by Electrolysis in an Offshore Platform Using Renewable Energies.” *International Journal of Hydrogen Energy* 42 (17): 12865–76. <https://doi.org/10.1016/j.ijhydene.2016.11.077>.

Singh, Aayush R., Brian A. Rohr, Jay A. Schwalbe, Matteo Cargnello, Karen Chan, Thomas F. Jaramillo, Ib Chorkendorff, and Jens K. Nørskov. 2017. “Electrochemical Ammonia Synthesis—The Selectivity Challenge.” *ACS Catalysis* 7 (1): 706–709. <https://doi.org/10.1021/acscatal.6b03035>.

Stori, Val. 2021. *Offshore Wind to Green Hydrogen: Insights from Europe*. Montpelier, VT: Clean Energy States Alliance.

Temeev, Alexander A., Victor P. Belokopytov, and Sergey A. Temeev. 2006. “An Integrated System of the Floating Wave Energy Converter and Electrolytic Hydrogen Producer.” *Renewable Energy* 31 (2): 225–39. <https://doi.org/10.1016/j.renene.2005.08.026>.

Teng, Li and Guo Chen. 2020. “Hydrogen-powered ship capable of absorbing tidal current energy and operation method.” CN111271210A, patent filed March 31, 2020, issued June 12, 2020. <https://patents.google.com/patent/CN111271210A/en>.

Terlip, Daniel, Kevin Harrison, and Michael Peters. 2015. “Hydrogen Component Validation.” Presented at the HFTO Annual Merit Review, 10 June 2015. https://www.hydrogen.energy.gov/pdfs/review15/tv019_terlip_2015_o.pdf.

Tetra Tech, Inc. 2007. *USE OF SHORE-SIDE POWER FOR OCEAN-GOING VESSELS: White Paper*. Pasadena, CA: Tetra Tech, Inc. <https://sustainableworldports.org/wp-content/uploads/AAPA-Use-of-Shore-side-Power-for-Ocean-going-Vessels-2007.pdf>.

Thomas, C. E. 2009. “Fuel Cell and Battery Electric Vehicles Compared.” *International Journal of Hydrogen Energy* 34 (15): 6005–20. <https://doi.org/10.1016/j.ijhydene.2009.06.003>.

Thorsen, Kjeld. 2014. “A water based modular power plant.” World Intellectual Property Organization WO2014196921A1, patent filed June 6, 2014, issued December 11, 2014. <https://patents.google.com/patent/WO2014196921A1/en>.

Thorson, Jacob and Christopher Matthews. 2022. *Marine Energy to Hydrogen Working Meeting: Workshop Report*. Golden, CO: National Renewable Energy Laboratory. NREL/TP-5700-79711. <https://www.nrel.gov/docs/fy22osti/79711.pdf>.

Tong, Wenming, Mark Forster, Fabio Dionigi, Sören Dresp, Roghayeh Sadeghi Erami, Peter Strasser, Alexander J. Cowan, and Pau Farràs. 2020. “Electrolysis of Low-Grade and Saline Surface Water.” *Nature Energy* 5 (5): 367–77. <https://doi.org/10.1038/s41560-020-0550-8>.

Trapanese, Marco. 2019. “A Permanent Magnet Linear Generator for the Enhancement of the Reliability of a Wave Energy Conversion System.” *IEEE Transactions on Industrial Electronics* 66 (6): 4934–4944. <https://doi.org/10.1109/TIE.2018.2838076>.

Troy, Paul James and William Albert Spencer. 2017. “Automated open ocean fish farm structures and systems for open ocean fish farming.” US9655347B2, patent filed August 30, 2011, issued May 23, 2017. <https://patents.google.com/patent/US9655347B2/en>.

U.S. Department of Energy (DOE). 2020. *Department of Energy Hydrogen Program Plan*. Washington, D.C.: DOE. DOE/EE-2128. <https://www.hydrogen.energy.gov/pdfs/hydrogen-program-plan-2020.pdf>.

———. 2021. “H2@Scale.” 2021. <https://www.energy.gov/eere/fuelcells/h2scale>.

U.S. Department of Energy Hydrogen and Fuel Cell Technologies Office (HFTO). 2011. “Reversible Fuel Cells Workshop.” <https://www.energy.gov/eere/fuelcells/reversible-fuel-cells-workshop>.

———. 2021. “Hydrogen Production: Electrolysis.” <https://www.energy.gov/eere/fuelcells/hydrogen-production-electrolysis>.

———. 2022. “Hydrogen Shot.” <https://www.energy.gov/eere/fuelcells/hydrogen-shot>.

U.S. Department of Energy Office of Energy Efficiency and Renewable Energy (EERE). 2016. *Fuel Cell Technologies Office Multi-Year Research, Development, and Demonstration Plan - Section 3.4: Fuel Cells*. Washington, D.C.: EERE. https://www.energy.gov/sites/prod/files/2017/05/f34/fcto_myrd_d_fuel_cells.pdf.

———. 2020a. “H2@Scale: Enabling affordable, reliable, clean, and secure energy across sectors.” <https://www.energy.gov/sites/prod/files/2020/07/f76/hfto-h2-at-scale-handout-2020.pdf>.

———. 2020b. “Hydrogen Storage.” Accessed December 21, 2020. <https://www.energy.gov/eere/fuelcells/hydrogen-storage>.

Van Cleve, F.B., C. Judd, A. Radil, J. Ahmann, and S.H. Geerlofs. 2013. *Geospatial Analysis of Technical and Economic Suitability for Renewable Ocean Energy Development on Washington’s Outer Coast*. Richland, WA: Pacific Northwest National Laboratory. PNNL-22554.

van Wijk, A. 2017. *The Green Hydrogen Economy in the Northern Netherlands*. Groningen, the Netherlands: Noordelijke Innovation Board. <http://profadvanwijk.com/wp-content/uploads/2017/04/NIB-BP-EN-DEF-webversie.pdf>.

Vincent, Immanuel and Dmitri Bessarabov. 2018. “Low Cost Hydrogen Production by Anion Exchange Membrane Electrolysis: A Review.” *Renewable and Sustainable Energy Reviews* 81 (2): 1690–1704. <https://doi.org/10.1016/j.rser.2017.05.258>.

Wang, Michael. 2017. “Greenhouse Gases, Regulated Emissions, and Energy Use in Technologies (version GREET1 MODEL).” Argonne National Laboratory. https://greet.es.anl.gov/greet_1_series.

Yang, Zhaoqing, Gabriel García-Medina, Wei-Cheng Wu, and Taiping Wang. 2020. “Characteristics and Variability of the Nearshore Wave Resource on the U.S. West Coast.” *Energy* 203 (July): 117818. <https://doi.org/10.1016/j.energy.2020.117818>.

Yin, Fengxiang, Xin Lin, Xiaobo He, Biaohua Chen, Guoru Li, and Huaqiang Yin. 2019. “High Faraday efficiency for electrochemical nitrogen reduction reaction on Co@N-doped carbon derived from a metal-organic framework under ambient conditions.” *Materials Letters* 248: 109–113. <https://doi.org/10.1016/j.matlet.2019.04.011>.

Yongqiang, Yue. 2017. “A kind of sea wave power generation system, offshore platform and hydrogen energy source base.” CN106837667A, patent filed January 16, 2017, issued June 13, 2017. <https://patents.google.com/patent/CN106837667A/en>.

Yu, Xiaomin, Peng Han, Zengxi Wei, Linsong Huang, Zhengxiang Gu, Sijia Peng, Jianmin Ma, and Gengfeng Zheng. 2018. “Boron-Doped Graphene for Electrocatalytic N₂ Reduction.” *Joule* 2 (8): 1610–1622. <https://doi.org/10.1016/j.joule.2018.06.007>.

Yu, Yi-Hsiang, Nathan Tom, and Dale Jenne. 2018. “Numerical Analysis on Hydraulic Power Take-Off for Wave Energy Converter and Power Smoothing Methods.” In *Volume 10: Ocean Renewable Energy*, V010T09A043. Madrid, Spain: American Society of Mechanical Engineers. <https://doi.org/10.1115/OMAEE2018-78176>.

Zhang, Rui, Long Jiao, Weijie Yang, Gang Wan, and Hai-Long Jiang. 2019. “Single-atom catalysts templated by metal-organic frameworks for electrochemical nitrogen reduction.” *Journal of Materials Chemistry A* 7: 26371–26377. <https://doi.org/10.1039/C9TA10206J>.

Zhiqing, Qi, Cao Shuai, Liu Xiaoman, and Hou Weipeng. 2020. “Hot-melt salt heat storage ocean temperature difference energy-solar energy combined hydrogen energy production system.” CN111677639A, patent filed June 30, 2020, issued September 18, 2020. <https://patents.google.com/patent/CN111677639A/en>.